

**UNITED STATES CODE – TITLE 46 – SHIPPING**

**CHAPTER 43—RECREATIONAL VESSELS**

Sec. 4301	Application
Sec. 4302	Regulations
Sec. 4303	Inspection and testing
Sec. 4304	Importation of nonconforming vessels and equipment
Sec. 4305	Exemptions
Sec. 4306	Federal preemption
Sec. 4307	Prohibited acts
Sec. 4308	Termination of unsafe operation
Sec. 4309	Investigation and reporting
Sec. 4310	Repair and replacement of defects
Sec. 4311	Penalties and injunctions

**Sec. 4301—Application**

(a) This chapter applies to a recreational vessel and associated equipment carried in the vessel on waters subject to the jurisdiction of the United States (including the territorial sea of the United States as described in Presidential Proclamation No. 5928 of December 27, 1988) and, for a vessel owned in the United States, on the high seas.

(b) Except when expressly otherwise provided, this chapter does not apply to a foreign vessel temporarily operating on waters subject to the jurisdiction of the United States.

(c) Until there is a final judicial decision that they are navigable waters of the United States, the following waters lying entirely in New Hampshire are declared not to be waters subject to the jurisdiction of the United States within the meaning of this section: Lake Winnisquam, Lake Winnepesaukee, parts of the Merrimack River, and their tributary and connecting waters.

**Sec. 4302—Regulations**

(a) The Secretary may prescribe regulations—

(1) establishing minimum safety standards for recreational vessels and associated equipment, and establishing procedures and tests required to measure conformance with those standards, with each standard—

(A) meeting the need for recreational vessel safety; and

(B) being stated, insofar as practicable, in terms of performance;

(2) requiring the installation, carrying, or use of associated equipment (including fuel systems, ventilation systems, electrical systems, sound-producing devices, firefighting equipment, lifesaving devices, signaling devices, ground tackle, life- and grab-rails, and navigational equipment) on recreational vessels and classes of recreational vessels subject to this chapter, and prohibiting the installation, carrying, or use of associated equipment that does not conform with safety standards established under this section; and

(3) requiring or permitting the display of seals, labels, plates, insignia, or other devices for certifying or evidencing compliance with safety regulations and standards of the United States Government for recreational vessels and associated equipment.

(b) Each regulation prescribed under this section shall specify an effective date that is not earlier than 180 days from the date the regulation was published, unless the Secretary finds that there exists a recreational vessel safety hazard so critical as to require an earlier effective date. However, this period may not be more than 24 months for cases involving, in the discretion of the Secretary, major product design, retooling, or major changes in the manufacturing process.

- (c) In prescribing regulations under this section, the Secretary shall, among other things—
- (1) consider the need for and the extent to which the regulations will contribute to recreational vessel safety;
  - (2) consider relevant available recreational vessel safety standards, statistics, and data, including public and private research, development, testing, and evaluation;
  - (3) not compel substantial alteration of a recreational vessel or item of associated equipment that is in existence, or the construction or manufacture of which is begun before the effective date of the regulation, but subject to that limitation may require compliance or performance, to avoid a substantial risk of personal injury to the public, that the Secretary considers appropriate in relation to the degree of hazard that the compliance will correct; and
  - (4) consult with the National Boating Safety Advisory Council established under section [13110](#) of this title about the considerations referred to in clauses (1)–(3) of this subsection.
- (d) Section [8903](#) of this title does not apply to a vessel being operated for bona fide dealer demonstrations provided without fee to business invitees. However, if on the basis of substantial evidence, the Secretary decides under this section that requiring vessels so operated to be under the control of licensed individuals is necessary for boating safety, then the Secretary may prescribe regulations requiring the licensing of individuals controlling these vessels in the same manner as provided in chapter [89](#) of this title for individuals in control of vessels carrying passengers for hire.

**Sec. 4303—Inspection and testing**

- (a) Subject to regulations, supervision, and reviews that the Secretary may prescribe, the Secretary may delegate to a person, private or public agency, or organization, or to an officer or employee under the supervision of that person or agency, any work, business, or function related to the testing, inspection, and examination necessary for compliance enforcement and for the development of data to enable the Secretary to prescribe regulations under section [4302](#) of this title.
- (b) The Secretary may—
- (1) conduct research, testing, and development necessary to carry out this chapter, including the procurement by negotiation or otherwise of experimental and other recreational vessels or associated equipment for research and testing purposes; and
  - (2) subsequently sell those vessels.

**Sec. 4304—Importation of nonconforming vessels and equipment**

The Secretary and the Secretary of the Treasury may authorize by joint regulations the importation of any nonconforming recreational vessel or associated equipment on conditions, including providing a bond, that will ensure that the recreational vessel or associated equipment will be brought into conformity with applicable safety regulations and standards of the Government before the vessel or equipment is operated on waters subject to the jurisdiction of the United States.

**Sec. 4305—Exemptions**

If the Secretary considers that recreational vessel safety will not be adversely affected, the Secretary may issue an exemption from this chapter or a regulation prescribed under this chapter.

**Sec. 4306—Federal preemption**

Unless permitted by the Secretary under section [4305](#) of this title, a State or political subdivision of a State may not establish, continue in effect, or enforce a law or regulation establishing a recreational vessel or associated equipment performance or other safety standard or imposing a requirement for associated equipment (except insofar as the State or political subdivision may, in the absence of the Secretary's disapproval, regulate the carrying or use of marine safety articles

to meet uniquely hazardous conditions or circumstances within the State) that is not identical to a regulation prescribed under section [4302](#) of this title.

**Sec. 4307—Prohibited acts**

- (a) A person may not—
- (1) manufacture, construct, assemble, sell or offer for sale, introduce or deliver for introduction into interstate commerce, or import into the United States, a recreational vessel, associated equipment, or component of the vessel or equipment unless—
    - (A) (i) it conforms with this chapter or a regulation prescribed under this chapter; and
    - (ii) it does not contain a defect which has been identified, in any communication to such person by the Secretary or the manufacturer of that vessel, equipment or component, as creating a substantial risk of personal injury to the public; or
    - (B) it is intended only for export and is so labeled, tagged, or marked on the recreational vessel or equipment, including any markings on the outside of the container in which it is to be exported;
  - (2) affix, attach, or display a seal, document, label, plate, insignia, or other device indicating or suggesting compliance with standards of the United States Government on, in, or in connection with, a recreational vessel or item of associated equipment that is false or misleading; or
  - (3) fail to provide a notification as required by this chapter or fail to exercise reasonable diligence in carrying out the notification and reporting requirements of this chapter.
- (b) A person may not operate a vessel in violation of this chapter or a regulation prescribed under this chapter.

**Sec. 4308—Termination of unsafe operation**

If an official charged with the enforcement of this chapter observes a recreational vessel being operated without sufficient lifesaving or firefighting devices or in an overloaded or other unsafe condition (as defined in regulations prescribed under this chapter) and, in the judgment of the official, the operation creates an especially hazardous condition, the official may direct the individual in charge of the recreational vessel to take immediate and reasonable steps necessary for the safety of individuals on board the vessel, including directing the individual in charge to return to a mooring and to remain there until the situation creating the hazard is corrected or ended.

**Sec. 4309—Investigation and reporting**

- (a) A recreational vessel manufacturer to whom this chapter applies shall establish and maintain records and reports and provide information the Secretary may require to enable the Secretary to decide whether the manufacturer has acted or is acting in compliance with this chapter and regulations prescribed under this chapter. On request of an officer, employee, or agent authorized by the Secretary, a recreational vessel manufacturer shall permit the officer, employee, or agent to inspect, at reasonable times, factories or other facilities, and records related to deciding whether the manufacturer has acted or is acting in compliance with this chapter and regulations prescribed under this chapter.
- (b) Information reported to or otherwise obtained by the Secretary or the representative of the Secretary under this section containing or related to a trade secret or other matter referred to in section [1905](#) of title [18](#), or authorized to be exempt from public disclosure by section [552\(b\)](#) of title [5](#), is confidential under section 1905. However, on approval of the Secretary, the information may be disclosed to other officers, employees, or agents concerned with carrying out this chapter or when it is relevant in a proceeding under this chapter.

**Sec. 4310—Repair and replacement of defects**

- (a) In this section, “associated equipment” includes only items or classes of associated equipment that the Secretary shall prescribe by regulation after deciding that the application of the requirements of this section to those items or classes of associated equipment is reasonable and in furtherance of this chapter.
- (b) If a recreational vessel or associated equipment has left the place of manufacture and the recreational vessel manufacturer discovers or acquires information that the manufacturer decides, in the exercise of reasonable and prudent judgment, indicates that a recreational vessel or associated equipment subject to an applicable regulation prescribed under section 4302 of this title either fails to comply with the regulation, or contains a defect that creates a substantial risk of personal injury to the public, the manufacturer shall provide notification of the defect or failure of compliance as provided by subsections (c) and (d) of this section within a reasonable time after the manufacturer has discovered the defect.
- (c) (1) The notification required by subsection (b) of this section shall be given to the following persons in the following manner:
- (A) by first class mail or by certified mail to the first purchaser for other than resale, except that the requirement for notification of the first purchaser shall be satisfied if the recreational vessel manufacturer exercises reasonable diligence in establishing and maintaining a list of those purchasers and their current addresses, and sends the required notice to each person on that list at the address appearing on the list.
  - (B) by first class mail or by certified mail to subsequent purchasers if known to the manufacturer.
  - (C) by first class mail or by certified mail or other more expeditious means to the dealers and distributors of the recreational vessels or associated equipment.
- (2) The notification required by subsection (b) of this section is required to be given only for a defect or failure of compliance discovered by the recreational vessel manufacturer within a reasonable time after the manufacturer has discovered the defect or failure, except that the manufacturer's duty of notification under paragraph (1)(A) and (B) of this subsection applies only to a defect or failure of compliance discovered by the manufacturer within one of the following appropriate periods:
- (A) if a recreational vessel or associated equipment required by regulation to have a date of certification affixed, 10 years from the date of certification.
  - (B) if a recreational vessel or associated equipment not required by regulation to have a date of certification affixed, 10 years from the date of manufacture.
- (d) The notification required by subsection (b) of this section shall contain a clear description of the defect or failure to comply, an evaluation of the hazard reasonably related to the defect or failure, a statement of the measures to correct the defect or failure, and an undertaking by the recreational vessel manufacturer to take those measures only at the manufacturer's cost and expense.
- (e) Each recreational vessel manufacturer shall provide the Secretary with a copy of all notices, bulletins, and other communications to dealers and distributors of that manufacturer, and to purchasers of recreational vessels or associated equipment of that manufacturer, about a defect related to safety in the recreational vessels or associated equipment, and any failure to comply with the regulation or order applicable to the recreational vessels or associated equipment. The Secretary may publish or otherwise disclose to the public information in the notices or other information the Secretary has that the Secretary considers will assist in carrying out this chapter. However, the Secretary may disclose any information that contains or relates to a trade secret only if the Secretary decides that the information is necessary to carry out this chapter.
- (f) If, through testing, inspection, investigation, or examination of reports, the Secretary decides that a recreational vessel or associated equipment to which this chapter applies contains a defect related to safety or fails to comply with an applicable regulation prescribed under this

chapter and notification under this chapter is appropriate, the Secretary shall notify the recreational vessel manufacturer of the defect or failure. The notice shall contain the findings of the Secretary and shall include a synopsis of the information on which they are based. The manufacturer may then provide the notification required by this chapter to the persons designated in this chapter or dispute the Secretary's decision. If disputed, the Secretary shall provide the manufacturer with an opportunity to present views and establish that there is no such defect or failure. When the Secretary considers it to be in the public interest, the Secretary may publish notice of the proceeding in the Federal Register and provide interested persons, including the National Boating Safety Advisory Council, with an opportunity to comment. If, after presentation by the manufacturer, the Secretary decides that the recreational vessel or associated equipment contains a defect related to safety or fails to comply with an applicable regulation, the Secretary may direct the manufacturer to provide the notifications specified in this chapter.

(g) The Secretary may prescribe regulations to carry out this section, including the establishment of procedures that require dealers and distributors to assist manufacturers in obtaining information required by this section. A regulation prescribed under this subsection does not relieve a manufacturer of any obligation imposed by this section.

### **Sec. 4311—Penalties and injunctions**

(a) A person willfully operating a recreational vessel in violation of this chapter or a regulation prescribed under this chapter shall be fined not more than \$5,000, imprisoned for not more than one year, or both.

(b) A person violating section [4307\(a\)\(1\)](#) of this title is liable to the United States Government for a civil penalty of not more than \$2,000, except that the maximum civil penalty may be not more than \$100,000 for a related series of violations. When a corporation violates section [4307\(a\)\(1\)](#), any director, officer, or executive employee of the corporation who knowingly and willfully ordered, or knowingly and willfully authorized, a violation is individually liable to the Government for the penalty, in addition to the corporation. However, the director, officer, or executive employee is not liable individually under this subsection if the director, officer, or executive employee can demonstrate by a preponderance of the evidence that—

- (1) the order or authorization was issued on the basis of a decision, in exercising reasonable and prudent judgment, that the defect or the nonconformity with standards and regulations constituting the violation would not cause or constitute a substantial risk of personal injury to the public; and
- (2) at the time of the order or authorization, the director, officer, or executive employee advised the Secretary in writing of acting under this clause and clause (1) of this subsection.

(c) A person violating any other provision of this chapter or other regulation prescribed under this chapter is liable to the Government for a civil penalty of not more than \$1,000. If the violation involves the operation of a vessel, the vessel also is liable in rem for the penalty.

(d) When a civil penalty of not more than \$200 has been assessed under this chapter, the Secretary may refer the matter of collection of the penalty directly to the United States magistrate of the jurisdiction in which the person liable may be found for collection procedures under supervision of the district court and under an order issued by the court delegating this authority under section [636\(b\)](#) of title [28](#).

(e) The district courts of the United States have jurisdiction to restrain a violation of this chapter, or to restrain the sale, offer for sale, introduction or delivery for introduction into interstate commerce, or importation into the United States, of a recreational vessel or associated equipment that the court decides does not conform to safety standards of the Government. A civil action under this subsection shall be brought by filing a petition by the Attorney General for the Government. When practicable, the Secretary shall give notice to a person against whom an

action for injunctive relief is contemplated and provide the person with an opportunity to present views and, except for a knowing and willful violation, shall provide the person with a reasonable opportunity to achieve compliance. The failure to give notice and provide the opportunity does not preclude the granting of appropriate relief by the district court.

- (f) A person is not subject to a penalty under this chapter if the person—
  - (1) establishes that the person did not have reason to know, in exercising reasonable care, that a recreational vessel or associated equipment does not conform with the applicable safety standards of the Government or that the person was not advised by the Secretary or the manufacturer of that vessel, equipment or component that the vessel, equipment or component contains a defect which creates a substantial risk of personal injury to the public; or
  - (2) holds a certificate issued by the manufacturer of that recreational vessel or associated equipment to the effect that the recreational vessel or associated equipment conforms to all applicable recreational vessel safety standards of the Government, unless the person knows or reasonably should have known that the recreational vessel or associated equipment does not so conform.
  
- (g) Compliance with this chapter or standards, regulations, or orders prescribed under this chapter does not relieve a person from liability at common law or under State law.

**CODE OF FEDERAL REGULATIONS – TITLE 33 – NAVIGATION AND NAVIGABLE WATERS**

**PART 84—ANNEX I: POSITIONING AND TECHNICAL DETAILS OF LIGHTS AND SHAPES**

Sec. 84.01	Definitions
Sec. 84.03	Vertical positioning and spacing of lights
Sec. 84.05	Horizontal positioning and spacing of lights
Sec. 84.07	Details of location of direction-indicating lights for fishing vessels, dredgers and vessels engaged in underwater operations
Sec. 84.09	Screens
Sec. 84.11	Shapes
Sec. 84.13	Color specification of lights
Sec. 84.15	Intensity of lights
Sec. 84.17	Horizontal sectors
Sec. 84.19	Vertical sectors
Sec. 84.21	Intensity of non-electric lights
Sec. 84.23	Maneuvering light
Sec. 84.24	High-speed craft
Sec. 84.25	Approval

**Sec. 84.01—Definitions**

(a) The term height above the hull means height above the uppermost continuous deck. This height shall be measured from the position vertically beneath the location of the light.

(b) High-speed craft means a craft capable of maximum speed in meters per second (m/s) equal to or exceeding:  $3.7 \nabla^{0.1667}$ ; where  $\nabla$  = displacement corresponding to the design waterline (meters<sup>3</sup>).

*Note to paragraph (b): The same formula expressed in pounds and knots is maximum speed in knots (kts) equal to exceeding 1.98 (lbs)  $\nabla^{0.1667}$ ; where  $\nabla$  = displacement corresponding to design waterline in pounds.*

(c) The term practical cut-off means, for vessels 20 meters or more in length, 12.5 percent of the minimum luminous intensity (Table 84.15(b)) corresponding to the greatest range of visibility for which the requirements of Annex I are met.

(d) The term Rule or Rules means the Inland Navigation Rules contained in sec. 2 of the Inland Navigational Rules Act of 1980 (Pub. L. 96-591, 94 Stat. 3415, 33 U.S.C. 2001, December 24, 1980) as amended.

[CGD 81-008, 46 FR 62447, Dec. 24, 1981, as amended by CGD 94-011, 63 FR 5731, Feb. 4, 1998]

**Sec. 84.03—Vertical positioning and spacing of lights**

(a) On a power-driven vessel of 20 meters or more in length the masthead lights shall be placed as follows:

- (1) The forward masthead light, or if only one masthead light is carried, then that light, at a height above the hull of not less than 5 meters, and, if the breadth of the vessel exceeds 5 meters, then at a height above the hull not less than such breadth, so however that the light need not be placed at a greater height above the hull than 8 meters;
- (2) When two masthead lights are carried the after one shall be at least 2 meters vertically higher than the forward one.

(b) The vertical separation of the masthead lights of power-driven vessels shall be such that in all normal conditions of trim the after light will be seen over and separate from the forward light at a distance of 1000 meters from the stem when viewed from water level.

- (c) The masthead light of a power-driven vessel of 12 meters but less than 20 meters in length shall be placed at a height above the gunwale of not less than 2.5 meters.
- (d) The masthead light, or the all-round light described in Rule 23(c), of a power-driven vessel of less than 12 meters in length shall be carried at least one meter higher than the sidelights.
- (e) One of the two or three masthead lights prescribed for a power-driven vessel when engaged in towing or pushing another vessel shall be placed in the same position as either the forward masthead light or the after masthead light, provided that the lowest after masthead light shall be at least 2 meters vertically higher than the highest forward masthead light.
- (f) (1) The masthead light or lights prescribed in Rule 23(a) shall be so placed as to be above and clear of all other lights and obstructions except as described in paragraph (f)(2) of this section.  
(2) When it is impracticable to carry the all-round lights prescribed in Rule 27(b)(i) below the masthead lights, they may be carried above the after masthead light(s) or vertically in between the forward masthead light(s) and after masthead light(s), provided that in the latter case the requirement of Sec. 84.05(d) shall be complied with.
- (g) The sidelights of a power-driven vessel shall be placed at least one meter lower than the forward masthead light. They shall not be so low as to be interfered with by deck lights.
- (h) [Reserved]
- (i) When the Rules prescribe two or three lights to be carried in a vertical line, they shall be spaced as follows:  
(1) On a vessel of 20 meters in length or more such lights shall be spaced not less than 1 meter apart, and the lowest of these lights shall, except where a towing light is required, be placed at a height of not less than 4 meters above the hull;  
(2) On a vessel of less than 20 meters in length such lights shall be spaced not less than 1 meter apart and the lowest of these lights shall, except where a towing light is required, be placed at a height of not less than 2 meters above the gunwale;  
(3) When three lights are carried they shall be equally spaced.
- (j) The lower of the two all-round lights prescribed for a vessel when engaged in fishing shall be a height above the sidelights not less than twice the distance between the two vertical lights.
- (k) The forward anchor light prescribed in Rule 30(a)(i), when two are carried, shall not be less than 4.5 meters above the after one. On a vessel of 50 meters or more in length this forward anchor light shall be placed at a height or not less than 6 meters above the hull.

[CGD 81-008, 46 FR 62447, Dec. 24, 1981, as amended by CGD 89-024, 55 FR 3947, Feb. 6, 1990]

#### **Sec. 84.05—Horizontal positioning and spacing of lights**

- (a) Except as specified in paragraph (e) of this section, when two masthead lights are prescribed for a power-driven vessel, the horizontal distance between them must not be less than one quarter of the length of the vessel but need not be more than 50 meters. The forward light must be placed not more than one half of the length of the vessel from the stem.
- (b) On a power-driven vessel of 20 meters or more in length the sidelights shall not be placed in front of the forward masthead lights. They shall be placed at or near the side of the vessel.
- (c) When the lights prescribed in Rule 27(b)(i) are placed vertically between the forward masthead light(s) and the after masthead light(s) these all-round lights shall be placed at a horizontal distance of not less than 2 meters from the fore and aft centerline of the vessel in the athwartship direction.



(d) When only one masthead light is prescribed for a power-driven vessel, this light must be exhibited forward of amidships. For a vessel of less than 20 meters in length, the vessel shall exhibit one masthead light as far forward as is practicable.

(e) On power-driven vessels 50 meters but less than 60 meters in length operated on the Western Rivers, and those waters specified in Sec. 89.25, the horizontal distance between masthead lights shall not be less than 10 meters.

[CGD 81-008, 46 FR 62447, Dec. 24, 1981, as amended by CGD 88-07, 53 FR 10533, April 1, 1988; CGD 94-011, 63 FR 5731, Feb. 4, 1998]

**Sec. 84.07—Details of location of direction-indicating lights for fishing vessels, dredgers and vessels engaged in underwater operations**

(a) The light indicating the direction of the outlying gear from a vessel engaged in fishing as prescribed in Rule 26(c)(ii) shall be placed at a horizontal distance of not less than 2 meters and not more than 6 meters away from the two all-round red and white lights. This light shall be placed not higher than the all-round white light prescribed in Rule 26(c)(i) and not lower than the sidelights.

(b) The lights and shapes on a vessel engaged in dredging or underwater operations to indicate the obstructed side and/or the side on which it is safe to pass, as prescribed in Rule 27(d)(i) and (ii), shall be placed at the maximum practical horizontal distance, but in no case less than 2 meters, from the lights or shapes prescribed in Rule 27(b)(i) and (ii). In no case shall the upper of these lights or shapes be at a greater height than the lower of the three lights or shapes prescribed in Rule 27(b)(i) and (ii).

**Sec. 84.09—Screens**

(a) The sidelights of vessels of 20 meters or more in length shall be fitted with mat black inboard screens and meet the requirements of Sec. 84.17. On vessels of less than 20 meters in length, the sidelights, if necessary to meet the requirements of Sec. 84.17, shall be fitted with mat black inboard screens. With a combined lantern, using a single vertical filament and a very narrow division between the green and red sections, external screens need not be fitted.

(b) On power-driven vessels less than 12 meters in length constructed after July 31, 1983, the masthead light, or the all-round light described in Rule 23(c) shall be screened to prevent direct illumination of the vessel forward of the operator's position.

**Sec. 84.11—Shapes**

(a) Shapes shall be black and of the following sizes:

- (1) A ball shall have a diameter of not less than 0.6 meter;
- (2) A cone shall have a base diameter of not less than 0.6 meter and a height equal to its diameter;
- (3) A diamond shape shall consist of two cones (as defined in paragraph (a)(2) of this section) having a common base.

(b) The vertical distance between shapes shall be at least 1.5 meter.

(c) In a vessel of less than 20 meters in length shapes of lesser dimensions but commensurate with the size of the vessel may be used and the distance apart may be correspondingly reduced.

**Sec. 84.13—Color specification of lights**

(a) The chromaticity of all navigation lights shall conform to the following standards, which lie within the boundaries of the area of the diagram specified for each color by the International Commission on Illumination (CIE), in the “Colors of Light Signals”, which is incorporated by reference. It is Publication CIE No. 2.2. (TC-1.6), 1975, and is available from the Illumination Engineering Society, 345 East 47th Street, New York, NY 10017. It is also available for inspection at the Office of the Federal Register, 800 North Capitol Street, NW., suite 700, Washington, DC. This incorporation by reference was approved by the Director of the Federal Register.

(b) The boundaries of the area for each color are given by indicating the corner co-ordinates, which are as follows:

- (1) White:
 

x	0.525	0.525	0.452	0.310	0.310	0.443
y	0.382	0.440	0.440	0.348	0.283	0.382
  
- (2) Green:
 

x	0.028	0.009	0.300	0.203
y	0.385	0.723	0.511	0.356
  
- (3) Red:
 

x	0.680	0.660	0.735	0.721
y	0.320	0.320	0.265	0.259
  
- (4) Yellow:
 

x	0.612	0.618	0.575	0.575
y	0.382	0.382	0.425	0.406

**Sec. 84.15—Intensity of lights**

(a) The minimum luminous intensity of lights shall be calculated by using the formula:

$$I = 3.43 \times 10^6 \times T \times D^2 \times K^{-D}$$

where

- I* is luminous intensity in candelas under service conditions,
- T* is threshold factor  $2 \times 10^{-7}$  lux,
- D* is range of visibility (luminous range) of the light in nautical miles,
- K* is atmospheric transmissivity. For prescribed lights the value of *K* shall be 0.8, corresponding to a meteorological visibility of approximately 13 nautical miles.

(b) A selection of figures derived from the formula is given in Table 84.15(b):

**Table 84.15(b)**

Range of visibility (luminous range) of light in nautical miles D	Minimum luminous intensity of light in candelas for K=0.8 I
1.....	0.9
2.....	4.3
3.....	12.0
4.....	27.0
5.....	52.0
6.....	94.0

**Sec. 84.17—Horizontal sectors**

- (a) (1) In the forward direction, sidelights as fitted on the vessel shall show the minimum required intensities. The intensities shall decrease to reach practical cut-off between 1 and 3 degrees outside the prescribed sectors.
- (2) For sternlights and masthead lights and at 22.5 degrees abaft the beam for sidelights, the minimum required intensities shall be maintained over the arc of the horizon up to 5 degrees within the limits of the sectors prescribed in Rule 21. From 5 degrees within the prescribed sectors the intensity may decrease by 50 percent up to the prescribed limits; it shall decrease steadily to reach practical cut-off at not more than 5 degrees outside the prescribed sectors.
- (b) All-round lights shall be so located as not to be obscured by masts, topmasts or structures within angular sectors of more than 6 degrees, except anchor lights prescribed in Rule 30, which need not be placed at an impracticable height above the hull, and the all-round white light described in Rule 23(d), which may not be obscured at all.
- (c) If it is impracticable to comply with paragraph (b) of this section by exhibiting only one all-round light, two all-round lights shall be used suitably positioned or screened to appear, as far as practicable, as one light at a minimum distance of one nautical mile.

*Note to paragraph (c): Tow unscreened all-round lights that are 1.28 meters apart or less will appear as one light to the naked eye at a distance of one nautical mile.*

[CGD 81-008, 46 FR 62447, Dec. 24, 1981, as amended by CGD 94-011, 63 FR 5731, Feb. 4, 1998]

**Sec. 84.19—Vertical sectors**

- (a) The vertical sectors of electric lights as fitted, with the exception of lights on sailing vessels underway and on unmanned barges, shall ensure that:
  - (1) At least the required minimum intensity is maintained at all angles from 5 degrees above to 5 degrees below the horizontal;
  - (2) At least 60 percent of the required minimum intensity is maintained from 7.5 degrees above to 7.5 degrees below the horizontal.
- (b) In the case of sailing vessels underway the vertical sectors of electric lights as fitted shall ensure that:
  - (1) At least the required minimum intensity is maintained at all angles from 5 degrees above to 5 degrees below the horizontal;
  - (2) At least 50 percent of the required minimum intensity is maintained from 25 degrees above to 25 degrees below the horizontal.
- (c) In the case of unmanned barges the minimum required intensity of electric lights as fitted shall be maintained on the horizontal.
- (d) In the case of lights other than electric lights these specifications shall be met as closely as possible.

[CGD 81-008, 46 FR 62447, Dec. 24, 1981, as amended by CGD 89-024, 55 FR 3947, Feb. 6, 1990]

**Sec. 84.21—Intensity of non-electric lights**

Non-electric lights shall so far as practicable comply with the minimum intensities, as specified in the Table given in Sec. 84.15.

**Sec. 84.23—Maneuvering light**

Notwithstanding the provisions of Sec. 84.03(f), the maneuvering light described in Rule 34(b) shall be placed approximately in the same fore and aft vertical plane as the masthead light or lights and, where practicable, at a minimum height of one-half meter vertically above the forward masthead light, provided that it shall be carried not less than one-half meter vertically above or below the after masthead light. On a vessel where only one masthead light is carried the maneuvering light, if fitted, shall be carried where it can best be seen, not less than one-half meter vertically apart from the masthead light.

**Sec. 84.25—Approval**

The construction of lights and shapes and the installation of lights on board the vessel must satisfy the Commandant, U.S. Coast Guard.

**CODE OF FEDERAL REGULATIONS – TITLE 33 – NAVIGATION AND NAVIGABLE WATERS**

**PART 86—ANNEX III: TECHNICAL DETAILS OF SOUND SIGNAL APPLIANCES**

<b>Subpart B</b>	<b>Bell or Gong</b>
Sec. 86.21	Intensity of signal
Sec. 86.23	Construction

**Subpart B—Bell or Gong**

**Sec. 86.21—Intensity of signal**

A bell or gong, or other device having similar sound characteristics shall produce a sound pressure level of not less than 110 dB at 1 meter.

**Sec. 86.23—Construction**

Bells and gongs shall be made of corrosion-resistant material and designed to give a clear tone. The diameter of the mouth of the bell shall be not less than 300 mm for vessels of more than 20 meters in length, and shall be not less than 200 mm for vessels of 12 to 20 meters in length. The mass of the striker shall be not less than 3 percent of the mass of the bell. The striker shall be capable of manual operation.

*Note: When practicable, a power-driven bell striker is recommended to ensure constant force.*

**CODE OF FEDERAL REGULATIONS – TITLE 33 – NAVIGATION AND NAVIGABLE WATERS**

**PART 159—MARINE SANITATION DEVICES**

<b>Subpart A</b>	<b>General</b>
Sec. 159.1	Purpose
Sec. 159.3	Definitions
Sec. 159.5	Requirements for vessel manufacturers
Sec. 159.7	Requirements for vessel operators

<b>Subpart B</b>	<b>Certification Procedures</b>
Sec. 159.11	Purpose
Sec. 159.12	Regulations for certification of existing devices
Sec. 159.12a	Certification of certain Type III devices
Sec. 159.14	Application for certification
Sec. 159.15	Certification
Sec. 159.16	Authorization to label devices
Sec. 159.17	Changes to certified devices
Sec. 159.19	Testing equivalency

**Subpart A—General**

**Sec. 159.1—Purpose**

This part prescribes regulations governing the design and construction of marine sanitation devices and procedures for certifying that marine sanitation devices meet the regulations and the standards of the Environmental Protection Agency promulgated under section 312 of the Federal Water Pollution Control Act (33 U.S.C. 1322), to eliminate the discharge of untreated sewage from vessels into the waters of the United States, including the territorial seas. Subpart A of this part contains regulations governing the manufacture and operation of vessels equipped with marine sanitation devices.

**Sec. 159.3—Definitions**

In this part:

Coast Guard means the Commandant or his authorized representative.

Discharge includes, but is not limited to, any spilling, leaking, pouring, pumping, emitting, emptying, or dumping.

Existing vessel includes any vessel, the construction of which was initiated before January 30, 1975.

Fecal coliform bacteria are those organisms associated with the intestine of warm-blooded animals that are commonly used to indicate the presence of fecal material and the potential presence of organisms capable of causing human disease.

Inspected vessel means any vessel that is required to be inspected under 46 CFR Ch. I.

Length means a straight line measurement of the overall length from the foremost part of the vessel to the aftermost part of the vessel, measured parallel to the centerline. Bow sprits, bumpkins, rudders, outboard motor brackets, and similar fittings or attachments are not to be included in the measurement.

Manufacturer means any person engaged in manufacturing, assembling, or importing of marine sanitation devices or of vessels subject to the standards and regulations promulgated under section 312 of the Federal Water Pollution Control Act.

Marine sanitation device and device includes any equipment for installation on board a vessel which is designed to receive, retain, treat, or discharge sewage, and any process to treat such sewage.

New vessel includes any vessel, the construction of which is initiated on or after January 30, 1975.

Person means an individual, partnership, firm, corporation, or association, but does not include an individual on board a public vessel.

Public vessel means a vessel owned or bare-boat chartered and operated by the United States, by a State or political subdivision thereof, or by a foreign nation, except when such vessel is engaged in commerce.

Recognized facility means any laboratory or facility listed by the Coast Guard as a recognized facility under this part.

Sewage means human body wastes and the wastes from toilets and other receptacles intended to receive or retain body waste.

Territorial seas means the belt of the seas measured from the line of ordinary low water along that portion of the coast which is in direct contact with the open sea and the line marking the seaward limit of inland waters, and extending seaward a distance of 3 miles.

Type I marine sanitation device means a device that, under the test conditions described in Secs. 159.123 and 159.125, produces an effluent having a fecal coliform bacteria count not greater than 1,000 per 100 milliliters and no visible floating solids.

Type II marine sanitation device means a device that, under the test conditions described in Secs. 159.126 and 159.126a, produces an effluent having a fecal coliform bacteria count not greater than 200 per 100 milliliters and suspended solids not greater than 150 milligrams per liter.

Type III marine sanitation device means a device that is designed to prevent the overboard discharge of treated or untreated sewage or any waste derived from sewage.

Uninspected vessel means any vessel that is not required to be inspected under 46 CFR Chapter I.

United States includes the States, the District of Columbia, the Commonwealth of Puerto Rico, the Virgin Islands, Guam, American Samoa, the Canal Zone, and the Trust Territory of the Pacific Islands.

Vessel includes every description of watercraft or other artificial contrivance used, or capable of being used, as a means of transportation on the waters of the United States.

[CGD 96-026, 61 FR 33668, June 28, 1996, as amended by CGD 95-028, 62 FR 51194, Sept. 30, 1997]

**Sec. 159.5—Requirements for vessel manufacturers**

No manufacturer may manufacture for sale, sell, offer for sale, or distribute for sale or resale any vessel equipped with installed toilet facilities unless it is equipped with:

- (a) An operable Type II or III device that has a label on it under Sec. 159.16 or that is certified under Sec. 159.12 or Sec. 159.12a; or

(b) An operable Type I device that has a label on it under Sec. 159.16 or that is certified under Sec. 159.12, if the vessel is 19.7 meters (65 feet) or less in length.

[CGD 95-028, 62 FR 51194, Sept. 30, 1997]

**Sec. 159.7—Requirements for vessel operators**

(a) No person may operate any vessel equipped with installed toilet facilities unless it is equipped with:

- (1) An operable Type II or III device that has a label on it under Sec. 159.16 or that is certified under Sec. 159.12 or Sec. 159.12a; or
- (2) An operable Type I device that has a label on it under Sec. 159.16 or that is certified under Sec. 159.12, if the vessel is 19.7 meters (65 feet) or less in length.

(b) When operating a vessel on a body of water where the discharge of treated or untreated sewage is prohibited by the Environmental Protection Agency under 40 CFR 140.3 or 140.4, the operator must secure each Type I or Type II device in a manner which prevents discharge of treated or untreated sewage. Acceptable methods of securing the device include—

- (1) Closing the seacock and removing the handle;
- (2) Padlocking the seacock in the closed position;
- (3) Using a non-releasable wire-tie to hold the seacock in the closed position; or
- (4) Locking the door to the space enclosing the toilets with a padlock or door handle key lock.

(c) When operating a vessel on a body of water where the discharge of untreated sewage is prohibited by the Environmental Protection Agency under 40 CFR 140.3, the operator must secure each Type III device in a manner which prevents discharge of sewage. Acceptable methods of securing the device include—

- (1) Closing each valve leading to an overboard discharge and removing the handle;
- (2) Padlocking each valve leading to an overboard discharge in the closed position; or
- (3) Using a non-releasable wire-tie to hold each valve leading to an overboard discharge in the closed position.

[CGH 95-028, 62 FR 51194, Sept. 30, 1997]

**Subpart B—Certification Procedures**

**Sec. 159.11—Purpose**

This subpart prescribes procedures for certification of marine sanitation devices and authorization for labels on certified devices.

**Sec. 159.12—Regulations for certification of existing devices**

(a) The purpose of this section is to provide regulations for certification of existing devices until manufacturers can design and manufacture devices that comply with this part and recognized facilities are prepared to perform the testing required by this part.

(b) Any Type III device that was installed on an existing vessel before January 30, 1975, is considered certified.

(c) Any person may apply to the Commanding Officer, USCG Marine Safety Center, 400 Seventh Street, SW., Washington, DC 20590 for certification of a marine sanitation device manufactured before January 30, 1976. The Coast Guard will issue a letter certifying the device if the applicant shows that the device meets Sec. 159.53 by:



- (1) Evidence that the device meets State standards at least equal to the standards in Sec. 159.53, or
  - (2) Test conducted under this part by a recognized laboratory, or
  - (3) Evidence that the device is substantially equivalent to a device certified under this section, or
  - (4) A Coast Guard field test if considered necessary by the Coast Guard.
- (d) The Coast Guard will maintain and make available a list that identifies each device certified under this section.
- (e) Devices certified under this section in compliance with Sec. 159.53 need not meet the other regulations in this part and may not be labeled under Sec. 159.16.

[CGD 73-83, 40 FR 4624, Jan. 30, 1975, as amended by CGD 75-213, 41 FR 15325, Apr. 12, 1976; CGD 82-063a, 48 FR 4776, Feb. 3, 1983; CGD 88-052, 53 FR 25122, July 1, 1988; CGD 96-026, 61 FR 33668, June 28, 1996; USCG-2001-9286, 66 FR 33641, June 25, 2001]

**Sec. 159.12a—Certification of certain Type III devices**

- (a) The purpose of this section is to provide regulations for certification of certain Type III devices.
- (b) Any Type III device is considered certified under this section if:
- (1) It is used solely for the storage of sewage and flushwater at ambient air pressure and temperature; and
  - (2) It is in compliance with Sec. 159.53(c).
- (c) Any device certified under this section need not comply with the other regulations in this part except as required in paragraphs (b)(2) and (d) of this section and may not be labeled under Sec. 159.16.
- (d) Each device certified under this section which is installed aboard an inspected vessel must comply with Sec. 159.97.

[CGD 76-145, 42 FR 11, Jan. 3, 1977]

**Sec. 159.14—Application for certification**

- (a) Any manufacturer may apply to any recognized facility for certification of a marine sanitation device. The application for certification must indicate whether the device will be used aboard all vessels or only aboard uninspected vessels and to which standard in Sec. 159.53 the manufacturer requests the device to be tested.
- (b) An application may be in any format but must be in writing and must be signed by an authorized representative of the manufacturer and include or be accompanied by:
- (1) A complete description of the manufacturer's production quality control and inspection methods, record keeping systems pertaining to the manufacture of marine sanitation devices, and testing procedures;
  - (2) The design for the device, including drawings, specifications and other information that describes the materials, construction and operation of the device;
  - (3) The installation, operation, and maintenance instructions for the device; and
  - (4) The name and address of the applicant and the manufacturing facility.
- (c) The manufacturer must furnish the recognized facility one device of each model for which certification is requested and samples of each material from which the device is constructed, that must be tested destructively under Sec. 159.117. The device furnished is for the testing required by this part except that, for devices that are not suited for unit testing, the manufacturer may

submit the design so that the recognized facility may determine the components of the device and materials to be submitted for testing and the tests to be performed at a place other than the facility. The Coast Guard must review and accept all such determinations before testing is begun.

(d) At the time of submittal of an application to a recognized facility the manufacturer must notify the Coast Guard of the type and model of the device, the name of the recognized facility to which application is being made, and the name and address of the manufacturer, and submit a signed statement of the times when the manufacturer will permit designated officers and employees of the Coast Guard to have access to the manufacturer's facilities and all records required by this part.

[CGD 73-83, 40 FR 4624, Jan. 30, 1975, as amended by CGD 75-213, 41 FR 15325, Apr. 12, 1976]

**Sec. 159.15—Certification**

(a) The recognized facility must evaluate the information that is submitted by the manufacturer in accordance with Sec. 159.14(b) (1), (2), and (3), evaluate the device for compliance with Secs. 159.53 through 159.95, test the device in accordance with Sec. 159.101 and submit to the Commanding Officer, USCG Marine Safety Center, 400 Seventh Street, SW., Washington, DC 20590 the following:

- (1) The information that is required under Sec. 159.14(b);
- (2) A report on compliance evaluation;
- (3) A description of each test;
- (4) Test results; and
- (5) A statement that is signed by the person in charge of testing, that the test results are accurate and complete.

(b) The Coast Guard certifies a test device, on the design of the device, if it determines, after consideration of the information that is required under paragraph (a) of this section, that the device meets the requirements in Subpart C of this part.

(c) The Coast Guard notifies the manufacturer and recognized facility of its determination under paragraph (b) of this section. If the device is certified, the Coast Guard includes a certification number for the device. If certification is denied, the Coast Guard notifies the manufacturer and recognized facility of the requirements of this part that are not met. The manufacturer may appeal a denial to the Commanding Officer, USCG Marine Safety Center, 400 Seventh Street, SW., Washington, DC 20590.

(d) If upon re-examination of the test device, the Coast Guard determines that the device does not in fact comply with the requirements of Subpart C of this part, it may terminate the certification.

[CGD 73-83, 40 FR 4624, Jan. 30, 1975, as amended by CGD 75-213, 41 FR 15326, Apr. 12, 1976; CGD 82-063a, 48 FR 4776, Feb. 3, 1983; CGD 88-052, 53 FR 25122, July 1, 1988; CGD 96-026, 61 FR 33668, June 28, 1996; USCG-2001-9286, 66 FR 33641, June 25, 2001]

**Sec. 159.16—Authorization to label devices**

(a) When a test device is certified under Sec. 159.15(b), the Coast Guard will issue a letter that authorizes the manufacturer to label each device that he manufactures with the manufacturer's certification that the device is in all material respects substantially the same as a test device certified by the U.S. Coast Guard pursuant to section 312 of the Federal Water Pollution Control Act Amendments of 1972.

(b) Certification placed on a device by its manufacturer under this section is the certification required by section 312(h)(4) of the Federal Water Pollution Control Act Amendments of 1972, which makes it unlawful for a vessel that is subject to the standards and regulations promulgated

under the Act to operate on the navigable waters of the United States, if such vessel is not equipped with an operable marine sanitation device certified pursuant to section 312 of the Act.

(c) Letters of authorization issued under this section are valid for 5 years, unless sooner suspended, withdrawn, or terminated and may be reissued upon written request of the manufacturer to whom the letter was issued.

(d) The Coast Guard, in accordance with the procedure in 46 CFR 2.75, may suspend, withdraw, or terminate any letter of authorization issued under this section if the Coast Guard finds that the manufacturer is engaged in the manufacture of devices labeled under this part that are not in all material respects substantially the same as a test device certified pursuant to this part.

**Sec. 159.17—Changes to certified devices**

(a) The manufacturer of a device that is certified under this part shall notify the Commanding Officer, USCG Marine Safety Center, 400 Seventh Street, SW., Washington, DC 20590 in writing of any change in the design of the device.

(b) A manufacturer shall include with a notice under paragraph (a) of this section a description of the change, its advantages, and the recommendation of the recognized facility as to whether the device remains in all material respects substantially the same as the original test device.

(c) After notice under paragraph (a) of this section, the Coast Guard notifies the manufacturer and the recognized facility in writing of any tests that must be made for certification of the device or for any change in the letter of authorization. The manufacturer may appeal this determination to the Commandant (G-MSE), U.S. Coast Guard, Washington, D.C. 20593-0001.

[CGD 73-83, 40 FR 4624, Jan. 30, 1975, as amended by CGD 82-063a, 48 FR 4776, Feb. 3, 1983; CGD 88-052, 53 FR 25122, July 1, 1988; CGD 96-026, 61 FR 33668, June 28, 1996; USCG-2001-9286, 66 FR 33641, June 25, 2001]

**Sec. 159.19—Testing equivalency**

(a) If a test required by this part may not be practicable or necessary, a manufacturer may apply to the Commanding Officer, USCG Marine Safety Center, 400 Seventh Street, SW., Washington, DC 20590 for deletion or approval of an alternative test as equivalent to the test requirements in this part. The application must include the manufacturer's justification for deletion or the alternative test and any alternative test data.

(b) The Coast Guard notifies the manufacturer of its determination under paragraph (a) of this section and that determination is final.

[CGD 73-83, 40 FR 4624, Jan. 30, 1975, as amended by CGD 82-063a, 48 FR 4776, Feb. 3, 1983; CGD 88-052, 53 FR 25122, July 1, 1988; CGD 96-026, 61 FR 33668, June 28, 1996; USCG-2001-9286, 66 FR 33641, June 25, 2001]

**CODE OF FEDERAL REGULATIONS – TITLE 33 – NAVIGATION AND NAVIGABLE WATERS**

**PART 179—DEFECT NOTIFICATION**

Sec. 179.01	Purpose
Sec. 179.03	Definitions
Sec. 179.05	Manufacturer discovered defects
Sec. 179.07	Notice given by “more expeditious means”
Sec. 179.09	Contents of notification
Sec. 179.11	Defects determined by the Commandant
Sec. 179.13	Initial report to the Commandant
Sec. 179.15	Follow-up report
Sec. 179.17	Penalties
Sec. 179.19	Address of the Commandant

**Sec. 179.01—Purpose**

This part prescribes rules to implement 46 U.S.C. 4310, governing the notification of defects in boats and associated equipment.

[CGD 93-055, 61 FR 13926, Mar. 28, 1996]

**Sec. 179.03—Definitions**

Associated equipment as used in this part, means the following equipment as shipped, transferred, or sold from the place of manufacture and includes all attached parts and accessories:

- (1) An inboard engine.
- (2) An outboard engine.
- (3) A stern drive unit.
- (4) An inflatable personal flotation device approved under 46 CFR 160.076.

Boat means any vessel—

- (1) Manufactured or used primarily for noncommercial use;
- (2) Leased, rented, or chartered to another for the latter’s noncommercial use; or
- (3) Operated as an uninspected passenger vessel subject to the requirements of 46 CFR Chapter I, Subchapter C.

Manufacturer means any person engaged in—

- (1) The manufacture, construction, or assembly of boats or associated equipment;
- (2) The manufacture or construction of components for boats and associated equipment to be sold for subsequent assembly; or
- (3) The importation into the United States for sale of boats, associated equipment, or components thereof.

[CGD 93-055, 61 FR 13926, Mar. 28, 1996, as amended by USCG-1999-5832, 64 FR 34716, June 29, 1999; USCG-1999-5040, 67 FR 34760, May 15, 2002]

**Sec. 179.05—Manufacturer discovered defects**

Each manufacturer who is required to furnish a notice of a defect or failure to comply with a standard or regulation under 46 U.S.C. 4310(b), shall furnish that notice within 30 days after the manufacturer discovers or acquires information of the defect or failure to comply.

[CGD 93-055, 61 FR 13926, Mar. 28, 1996]

**Sec. 179.07—Notice given by “more expeditious means”**

Each manufacturer who gives notice by more expeditious means as provided for in 46 U.S.C. 4310(c)(1)(C), must give such notice in writing.

[CGD 93-055, 61 FR 13926, Mar. 28, 1996]

**Sec. 179.09—Contents of notification**

Each notice required under 46 U.S.C. 4310(b) must include the following additional information:

- (a) The name and address of the manufacturer.
- (b) Identifying classifications including the make, model year, if appropriate, the inclusive dates (month and year) of the manufacture, or serial numbers and any other data necessary to describe the boats or associated equipment that may be affected.

[CGD 72-55R, 37 FR 15776, Aug. 4, 1972, as amended by CGD 93-055, 61 FR 13926, Mar. 28, 1996]

**Sec. 179.11—Defects determined by the Commandant**

A manufacturer who is informed by the Commandant under 46 U.S.C. 4310(f) that a boat or associated equipment contains a defect relating to safety or failure to comply with a standard or regulation issued under the authority of 46 U.S.C. 4302, shall within 30 days of receipt of the information—

- (a) Furnish the notification described in 46 U.S.C. 4310(d) to the persons designated in 46 U.S.C. 4310(c), or
- (b) Provide information to the Commandant by certified mail stating why the manufacturer believes there is no defect relating to safety or failure of compliance.

[CGD 93-055, 61 FR 13926, Mar. 28, 1996]

**Sec. 179.13—Initial report to the Commandant**

- (a) When a manufacturer gives a notification required under 46 U.S.C. 4310, the manufacturer shall concurrently send to the Commandant by certified mail—
  - (1) A true or representative copy of each notice, bulletin, and other communication given to persons required to be notified under 46 U.S.C. 4310(c);
  - (2) The manufacturer's best estimate of the total number of boats or items of associated equipment potentially affected by the defect or failure to comply with a standard or regulation prescribed under 46 U.S.C. 4302; and
  - (3) If discovered or determined by the manufacturer, a chronology of all principal events upon which the determination is based.
- (b) A manufacturer may submit an item required by paragraph (a) of this section that is not available at the time of submission to the Commandant when it becomes available if the manufacturer explains why it was not submitted within the time required and estimates when it will become available.

[CGD 72-55R, 37 FR 15776, Aug. 4, 1972, as amended by CGD 93-055, 61 FR 13926, Mar. 28, 1996]

**Sec. 179.15—Follow-up report**

- (a) Each manufacturer who makes an initial report required by Sec. 179.13 shall submit a follow-up report to the Commandant by certified mail within 60 days after the initial report. The follow-up report must contain at least the following information:

- (1) A positive identification of the initial report;
  - (2) The number of units in which the defect was discovered as of the date of the follow-up report;
  - (3) The number of units in which corrective action has been completed as of the date of the follow-up report;
  - (4) The number of first purchasers not notified because of an out-of-date name or address, or both; and
  - (5) An updating of the information required by Sec. 179.13.
- (b) Each manufacturer shall submit any additional follow-up reports requested by the Commandant.

**Sec. 179.17—Penalties**

Each manufacturer who fails to comply with a provision of 46 U.S.C. 4310 or the regulations in this part, is subject to the penalties as prescribed in 46 U.S.C. 4311.

[CGD 93-055, 61 FR 13926, Mar. 28, 1996]

**Sec. 179.19—Address of the Commandant.**

(a) Each report and communication sent to the Coast Guard and required by this part concerning boats and associated equipment other than inflatable personal flotation devices, must be submitted to Commandant (G-OPB-3), U.S. Coast Guard, 2100 Second St., SW., Washington, DC 20593-0001.

(b) Each report and communication sent to the Coast Guard and required by this part concerning inflatable personal flotation devices, must be submitted to Commandant (G-MSE-4), U.S. Coast Guard, 2100 Second St. SW., Washington, DC 20593-0001.

[CGD 93-055, 61 FR 13927, Mar. 28, 1996; CGD 96-026, 61 FR 36629, July 12, 1996]

DEPARTMENT OF HOMELAND SECURITY U.S. COAST GUARD CG-4917 (Rev. 9-93)	<h2 style="margin: 0;">DEFECT/NONCOMPLIANCE REPORT</h2> <p style="margin: 5px 0;">Mail to: Commandant (G-OPB-3), USCG, Washington, DC 20593-0001</p>	OMB NO. 1625-0010 Expires 12/31/2005
The Coast Guard estimates that the average burden for this report form is one hour. You may submit any comments concerning the accuracy of this burden estimate or any suggestions for reducing the burden to: Commandant (G-OPB-3), U.S. Coast Guard, Washington, DC 20593-0001 or Office of Management and Budget, Paperwork Reduction Project (1625-0010), Washington, DC 20503.		CAMPAIGN NUMBER
1. NAME AND ADDRESS OF COMPANY CONDUCTING DEFECT NOTIFICATION CAMPAIGN (include ZIPCODE)		
2. NAME AND PHONE NUMBER OF PERSON TO CONTACT		
3. IF DEFECTIVE COMPONENT, MANUFACTURER NAME AND ADDRESS:		
4a. IDENTIFICATION OF BOATS POTENTIALLY INVOLVED <i>(use other means or additional space on Page 2 if necessary):</i>		
MODEL _____	HIN _____	to _____
MODEL _____	HIN _____	to _____
MODEL _____	HIN _____	to _____
MODEL _____	HIN _____	to _____
4b. IF PRODUCTS INVOLVED ARE NOT BOATS <i>(use other means or additional space on Page 2 if necessary):</i>		
MODEL _____	SERIAL NOS. _____	to _____ YEAR _____
MODEL _____	SERIAL NOS. _____	to _____ YEAR _____
MODEL _____	SERIAL NOS. _____	to _____ YEAR _____
5. DESCRIPTION OF DEFECT OR NONCOMPLIANCE:		
6. DEGREE OF DANGER TO THE PUBLIC WITH CONTINUED USE OF THE PRODUCT WITHOUT REPAIR OR CORRECTION:		
7. MANNER IN WHICH PRODUCTS RECALLED WILL BE CORRECTED <i>(use additional space on Page 2 if necessary):</i>		
a. Who will perform corrections?		
b. Where will corrections be performed?		

PREVIOUS EDITIONS ARE OBSOLETE

c. When will corrections be performed?

d. How will corrections be performed?

8. ACTIONS TAKEN TO DATE TO CORRECT THIS DEFECT OR NONCOMPLIANCE:

<p>9. LOCATION OF UNITS:</p> <p>a. Number of units sold to consumers: _____</p> <p>b. Number of units at the factory: _____</p> <p>c. Number of units shipped to dealers: _____</p> <p>d. Locations of other units: _____</p> <p>_____</p>	<p>10. CURRENT STATUS OF CAMPAIGN:</p> <p>a. Number of units which might contain the problem: _____</p> <p>b. Number of first purchasers notified about the problem: _____</p> <p>c. Number of dealers or distributors notified about the problem: _____</p> <p>d. Number of units corrected or repaired: _____</p> <p>e. Number of units inspected which did not have problem: _____</p> <p>f. Number of owners who refused the offer to repair or correct _____  <i>(an owner who refuses must do so in writing)</i></p>
--	--

11. IF ANY OF THE INFORMATION REQUESTED IN 9. AND 10. ABOVE IS NOT AVAILABLE WHEN SUBMITTING THIS REPORT, WHEN WILL THE INFORMATION BE AVAILABLE?

**THIS FORM IS AUTHORIZED BY 46 U.S.C. CHAPTER 43 AND 33 CFR 179 FOR THE COLLECTION OF INFORMATION CONCERNING THE PRODUCTS INVOLVED IN THIS DEFECT NOTIFICATION AND RECALL CAMPAIGN. THE INFORMATION PROVIDED ON THIS FORM WILL BECOME A PART OF THE OFFICIAL U.S.COAST GUARD FILE COVERING THIS CAMPAIGN AND WILL BE USED IN EVALUATING THE DILIGENCE WITH WHICH YOUR COMPANY CONDUCTS THIS CAMPAIGN. FAILURE TO SUBMIT THIS REPORT FORM WITHIN SPECIFIED TIME CONSTRAINTS CAN RESULT IN A CIVIL PENALTY OF \$1000.**

SIGNATURE AND TITLE OF PREPARER: \_\_\_\_\_ DATE: \_\_\_\_\_

SPACE FOR ADDITIONAL INFORMATION:

*List the model name, length, model year and type of propulsion for boats for which affected Hull Identification Number (HIN) sequences in item 4a. are not available*

**THE COAST GUARD MUST RECEIVE THIS REPORT ON OR BEFORE:**



DEPARTMENT OF HOMELAND SECURITY U.S. COAST GUARD CG-4918(Rev. 9-93)	<h2 style="margin: 0;">CAMPAIGN UPDATE REPORT</h2> <p style="margin: 0;">Mail to: Commandant (G-OPB-3), USCG, Washington, DC 20593-0001</p>	OMB NO. 1625-0010 Expires 12-31-2005
1. NAME OF COMPANY CONDUCTING DEFECT NOTIFICATION CAMPAIGN  (See item 10.a. of the Defect/Noncompliance Report )	CAMPAIGN NUMBER	
	REPORT NUMBER	
2. NUMBER OF UNITS WHICH MIGHT CONTAIN THE PROBLEM (See item 10.a. of the Defect/Noncompliance Report )		
3. NUMBER OF FIRST PURCHASERS NOTIFIED ABOUT THE PROBLEM (See item 10.b. of the Defect/Noncompliance Report )		
4. NUMBER OF DEALERS/DISTRIBUTORS NOTIFIED (See item 10.c. of the Defect/Noncompliance Report )		
5. NUMBER OF UNITS CORRECTED OR REPAIRED (See item 10.d. of the Defect/Noncompliance Report )		
6. NUMBER OF UNITS INSPECTED WHICH DID NOT HAVE THE PROBLEM (See item 10.e. of the Defect/Noncompliance Report )		
7. NUMBER OF OWNERS WHO REFUSED THE OFFER TO REPAIR OR CORRECT (See item 10.f. of the Defect/Noncompliance Report ) <i>Your files must contain written evidence of each owner's refusal</i>		
8. SHOULD THE COAST GUARD CONSIDER TERMINATION OF THIS CAMPAIGN?  <input type="checkbox"/> NO <input type="checkbox"/> YES <i>(If yes, please state reasons)</i>		
<p style="margin: 0;"><b>THIS FORM IS AUTHORIZED BY 46 U.S.C. CHAPTER 43 AND 33 CFR 179 FOR THE COLLECTION OF INFORMATION CONCERNING THE PRODUCTS INVOLVED IN THIS DEFECT NOTIFICATION AND RECALL CAMPAIGN. THE INFORMATION PROVIDED ON THIS FORM WILL BECOME A PART OF THE OFFICIAL U.S. COAST GUARD FILE COVERING THIS CAMPAIGN AND WILL BE USED IN EVALUATING THE DILIGENCE WITH WHICH YOUR COMPANY CONDUCTS THIS CAMPAIGN. FAILURE TO SUBMIT THIS REPORT FORM WITHIN SPECIFIED TIME CONSTRAINTS CAN RESULT IN A CIVIL PENALTY OF \$1000.</b></p>		
SIGNATURE AND TITLE OF PREPARER:	DATE:	
<p style="margin: 0;"><small>An agency may not conduct or sponsor and a person is not required to respond to an information collection, unless it displays a currently valid OMB Control Number. The Coast Guard estimates that the average burden for this report form is 30 minutes. You may submit any comments concerning the accuracy of this burden estimate or any suggestions for reducing the burden to: Commandant (G-OPB-3), U.S. Coast Guard, Washington, DC 20593-0001 or Office of Management and Budget, Paperwork Reduction Project (1625-0010), Washington, DC 20503.</small></p>		
SPACE FOR ADDITIONAL INFORMATION:	<b>THE COAST GUARD MUST RECEIVE THIS REPORT ON OR BEFORE:</b>	



## CODE OF FEDERAL REGULATIONS – TITLE 33 – NAVIGATION AND NAVIGABLE WATERS

## PART 181—MANUFACTURER REQUIREMENTS

**Subpart A****General**

- Sec. 181.1 Purpose and applicability
- Sec. 181.3 Definitions
- Sec. 181.4 Incorporation by reference

**Subpart B****Manufacturer Certification of Compliance**

- Sec. 181.5 Purpose and applicability
- Sec. 181.7 Compliance certification label required
- Sec. 181.9 Affixing labels
- Sec. 181.11 Exceptions to labeling requirement
- Sec. 181.13 Removal of labels
- Sec. 181.15 Contents of labels
- Sec. 181.17 Label numbers and letters
- Sec. 181.19 Construction of labels

**Subpart C****Identification of Boats**

- Sec. 181.21 Purpose, applicability and effective dates
- Sec. 181.23 Hull identification numbers required
- Sec. 181.25 Hull identification number format
- Sec. 181.27 Information displayed near hull identification number
- Sec. 181.29 Hull identification number display
- Sec. 181.31 Manufacturer identification code assignment
- Sec. 181.33 Conditions for use of manufacturer identification codes
- Sec. 181.35 Removal of numbers

**Subparts D-F****[Reserved]****Subpart A—General****Sec. 181.1—Purpose and applicability**

This part prescribes requirements for the certification of boats and associated equipment and identification of boats to which 46 U.S.C. Chapter 43 applies.

[CGD 85-002, 51 FR 37573, Oct. 23, 1986]

**Sec. 181.3—Definitions**

As used in this part:

Associated equipment means:

- (1) Any system, part, or component of a boat as originally manufactured or any similar part or component manufactured or sold for replacement, repair, or improvement of such system, part, or component;
- (2) Any accessory or equipment for, or appurtenance to, a boat; and
- (3) Any marine safety article, accessory, or equipment intended for use by a person on board a boat; but
- (4) Excluding radio equipment.

Boat means any vessel—

- (1) Manufactured or used primarily for noncommercial use;
  - (2) Leased, rented, or chartered to another for the latter's noncommercial use; or
- Operated as an uninspected passenger vessel subject to the requirements of 46 CFR chapter I, subchapter C.

Date of certification means the date on which a boat or item of associated equipment is certified to comply with all applicable U.S. Coast Guard safety standards in effect on that date.

Date of manufacture means the month and year during which construction or assembly of a boat or item of associated equipment begins.

Manufacturer means any person engaged in:

- (1) The manufacture, construction, or assembly of boats or associated equipment; or
- (2) The importation into the United States for sale of boats, associated equipment, or components thereof.

Model year means the period beginning August 1 of any year and ending on July 31 of the following year. Each model year is designated by the year in which it ends.

Private label merchandiser means any person engaged in the business of selling and distributing, under his own trade name, boats, or items of associated equipment manufactured by another.

[CGD 96-026, 61 FR 33669, June 28, 1996; 61 FR 36786, July 12, 1996, as amended by USCG-1999-5040, May 15, 2002]

#### **Sec. 181.4—Incorporation by reference**

(a) Certain materials are incorporated by reference into this part with the approval of the Director of the Federal Register in accordance with 5 U.S.C. 552(a). To enforce any edition other than the one listed in paragraph (b) of this section, notice of change must be published in the Federal Register and the material made available to the public. All approved material is on file at the Office of the Federal Register, 800 North Capitol Street, NW., suite 700, Washington, DC, and at the Lifesaving and Fire Safety Standards Division (G-MSE-4), 2100 Second Street, SW., Washington, DC 20593-0001, and is available from the sources listed in paragraph (b) of this section.

(b) The materials approved for incorporation by reference in this part, and the sections affected are:

Underwriters Laboratories, Inc. (UL)  
12 Laboratory Drive, Research Triangle Park, NC 27709-3995  
UL 1123, Marine Buoyant Devices, 181.703, February 17, 1995.

[CGD 81-023, 55 FR 32034, Aug. 6, 1990, as amended by CGD 93-055, 61 FR 13927, Mar. 28, 1996; CGD 96-026, 61 FR 33669, June 28, 1996; USCG-2000-7223, 65 FR 40059, June 29, 2000]

**Subpart B—Manufacturer Certification of Compliance****Sec. 181.5—Purpose and applicability**

This subpart prescribes requirements for the certification of boats and associated equipment to which 46 U.S.C. Chapter 43 applies and to which a safety standard prescribed in Part 183 of this chapter applies.

[CGD 85-002, 51 FR 37573, Oct. 23, 1986]

**Sec. 181.7—Compliance certification label required**

Unless there is affixed to it a certification label that contains the information required by Sec. 181.15:

- (a) No person who manufactures, constructs, or assembles a boat or associated equipment may deliver that boat or equipment for the purpose of sale;
- (b) No person may import into the United States any boat or associated equipment; and
- (c) No person engaged in the business of selling or distributing boats or associated equipment may sell or offer for sale any boat or associated equipment.

**Sec. 181.9—Affixing labels**

(a) Each manufacturer of a boat or item of associated equipment to which a standard or regulation prescribed in Part 183 of this chapter applies shall affix a certification label that contains the information required by Sec. 181.15 to that boat or equipment before it:

- (1) Leaves the place of manufacture for the purpose of sale; or
- (2) Is imported.

(b) The manufacturer of a boat or item of associated equipment that is sold to a private label merchandiser may, at the option of the private label merchandiser, affix a certification label identifying the private label merchandiser as the manufacturer before the boat or item of associated equipment leaves the place of manufacture.

**Sec. 181.11—Exceptions to labeling requirement**

(a) This part does not apply to boats or associated equipment intended solely for export, and so labeled, tagged, or marked on the boat or equipment and on the outside of the container, if any, which is exported.

(b) If an item of associated equipment is so small that a certification label that meets the requirements in Sec. 181.15 cannot be affixed to it, a certification label that contains the information required by Sec. 181.15 may be printed on the smallest container in which the item is packed or on a slip packed with the item.

(c) This subpart does not apply to any outboard motor or starting control to which Sec. 183.710 of this chapter applies.

[CGD 72-60, 37 FR 15779, Aug. 4, 1972, as amended by CGD 79-137, 46 FR 3515, Jan. 15, 1981; 46 FR 9579, Jan. 29, 1981]

**Sec. 181.13—Removal of labels**

No person may remove a label required by this part or remove or alter any information on a label required by this part, unless authorized by the Commandant.

**Sec. 181.15—Contents of labels**

- (a) Each label required by Sec. 181.7 must contain:
  - (1) The name and address of the manufacturer or private label merchandiser who certifies that the boat or item of associated equipment complies with the standards prescribed in Part 183 of this subchapter; and
  - (2) Except as provided in paragraph (c) of this section, the words:
    - (i) “This (insert ‘Boat’ or ‘Equipment’) Complies With U.S. Coast Guard Safety Standards In Effect On (insert date of certification as prescribed in paragraph (b) of this section)”;
    - (ii) If the item being certified is a boat, the label may show the words, “This Boat Complies With U.S. Coast Guard Safety Standards In Effect On The Date of Certification.”
  
- (b) Date of certification must be no earlier than the date on which construction or assembly began and no later than the date on which the boat or item of associated equipment leaves the place of manufacture or assembly or import for the purposes of sale.
  
- (c) [Reserved]
  
- (d) Except as provided in paragraph (e) of this section, the manufacturer may, in addition to the information required by paragraphs (a) and (b) of this section, display on the certification label any or all of the following information:
  - (1) Model name or designation.
  - (2) Hull identification number (if a boat) or serial number (if an item of associated equipment).
  - (3) Model year.
  
- (e) Display of the hull identification number on the certification label does not satisfy the display requirements of Sec. 181.29.
  
- (f) Each boat which displays a maximum horsepower capacity determined in accordance with Sec. 183.53(b) must, in addition to the information required by paragraphs (a), (b) and (d) of this section, display on the certification label, the following statement in letters no less than one-quarter of an inch in height:

THIS BOAT IS INTENDED FOR RACING AND OTHER HIGH PERFORMANCE ACTIVITIES.  
THE SKILL REQUIRED MAY EXCEED THE ABILITIES OF SOME OPERATORS.

[CGD 72-60, 37 FR 15779, Aug. 4, 1972, as amended by CGD 83-012, 49 FR 39327, Oct. 5, 1984; CGD 85-002, 51 FR 37573, Oct. 23, 1986; USCG-1999-5832, 64 FR 34716, June 29, 1999]

**Sec. 181.17—Label numbers and letters**

Letters and numbers on each label must:

- (a) Be no less than one-eighth of an inch in height; and
  
- (b) Contrast with the basic color of the label, except that the date of certification may be permanently stamped, engraved, or embossed on the label.

**Sec. 181.19—Construction of labels.**

- (a) Each label must be made of material that can withstand exposure to water, oil, salt spray, direct sunlight, heat, cold, and wear expected in normal use of the boat or item of associated equipment without deterioration of legibility.
  
- (b) Each label must be made of material that shows visible traces of the alteration or removal of information on the label.

## **Subpart C—Identification of Boats**

### **Sec. 181.21—Purpose, applicability and effective dates**

Source: CGD 79-013, 48 FR 40718, Sept. 9, 1983, unless otherwise noted.

This subpart prescribes the requirements for identification of boats to which section 46 U.S.C. 4301 applies.

[CGD 79-013, 48 FR 40718, Sept. 9, 1983, as amended by USCG-1998-3799, 63 FR 35534, June 30, 1998; USCG-1999-5832, 64 FR 34716, June 29, 1999]

### **Sec. 181.23—Hull identification numbers required**

- (a) A manufacturer (or importer), as defined in Sec. 181.3 of this part, must identify each boat produced or imported with two hull identification numbers that meet the requirements of this subpart:
- (1) A primary hull identification number affixed in accordance with Secs. 181.29(a) and (c) of this subpart; and
  - (2) A duplicate hull identification number affixed in accordance with Secs. 181.29(b) and (c) of this subpart.
- (b) A person who builds or imports a boat for his or her own use and not for the purposes of sale, must identify that boat with two hull identification numbers that meet the requirements of this subpart.
- (c) No person may assign the same hull identification number to more than one boat.

### **Sec. 181.25—Hull identification number format**

Each of the hull identification numbers required by Sec. 181.23 must consist of twelve characters, uninterrupted by slashes, hyphens, or spaces, as follows:

- (a) The first three characters must be a manufacturer identification code assigned under Sec. 181.31(a) or the importer designation assigned under Sec. 181.31(b).
- (b) Characters four through eight must be a serial number assigned by the manufacturer in letters of the English alphabet, or Arabic numerals, or both, except the letters I, O, and Q.
- (c) Characters nine and ten must indicate the month and year of certification when a date of certification is required. In all other cases characters nine and ten must indicate the date of manufacture. The date indicated can be no earlier than the date construction or assembly began and no later than the date the boat leaves the place of manufacture or assembly or is imported into the United States for the purposes of sale. Character nine must be indicated using letters of the English alphabet. The first month of the year, January, must be designated by the letter "A", the second month, February, by the letter "B", and so on until the last month of the year, December. Character ten must be the last digit of the year of manufacture or certification and must be an Arabic numeral.
- (d) Characters eleven and twelve must indicate the model year using Arabic numerals for the last two numbers of the model year such as "82" for 1982 and "83" for 1983.

### **Sec. 181.27—Information displayed near hull identification number**

If additional information is displayed on the boat within two inches of the hull identification number, that information must be separated from the hull identification number by means of borders or must be on a separate label so that it will not be interpreted as part of the hull identification number.

**Sec. 181.29—Hull identification number display**

Two identical hull identification numbers are required to be displayed on each boat hull.

- (a) The primary hull identification number must be affixed—
  - (1) On boats with transoms, to the starboard outboard side of the transom within two inches of the top of the transom, gunwale, or hull/deck joint, whichever is lowest.
  - (2) On boats without transoms or on boats on which it would be impractical to use the transom, to the starboard outboard side of the hull, aft, within one foot of the stern and within two inches of the top of the hull side, gunwale or hull/deck joint, whichever is lowest.
  - (3) On catamarans and pontoon boats which have readily replaceable hulls, to the aft crossbeam within one foot of the starboard hull attachment.
  - (4) If the hull identification number would not be visible, because of rails, fittings, or other accessories, the number must be affixed as near as possible to the location specified in paragraph (a) of this section.
- (b) The duplicate hull identification number must be affixed in an unexposed location on the interior of the boat or beneath a fitting or item of hardware.
- (c) Each hull identification number must be carved, burned, stamped, embossed, molded, bonded, or otherwise permanently affixed to the boat so that alteration, removal, or replacement would be obvious. If the number is on a separate plate, the plate must be fastened in such a manner that its removal would normally cause some scarring of or damage to the surrounding hull area. A hull identification number must not be attached to parts of the boat that are removable.
- (d) The characters of each hull identification number must be no less than one-fourth of an inch high.

[CGD 79-013, 48 FR 40718, Sept. 19, 1983; 48 FR 53558, Nov. 28, 1983]

**Sec. 181.31—Manufacturer identification code assignment**

- (a) Each person required by Sec. 181.23 to affix hull identifications numbers must request a manufacturer identification code in writing from the Recreational Boating Product Assurance Division, 2100 Second Street SW., Washington, DC 20593-0001. The request must indicate the manufacturer's name and U.S. address along with the general types and lengths of boats that will be manufactured.
- (b) For boats manufactured outside of the jurisdiction of the United States, a U.S. importer must obtain a manufacturer identification code as required by paragraph (a) of this section. The request of an importer, as defined in Sec. 181.3 of this subpart, must indicate the importer's name and U.S. address along with a list of the manufacturers, their addresses, and the general types and sizes of boats that will be imported. If a nation has a hull identification number system which has been accepted by the U.S. Coast Guard for the purpose of importing boats, it may be used by the importer instead of the one specified within this subpart. To request a list of those nations having such a numbering system, write to the Recreational Boating Product Assurance Division, 2100 Second Street SW., Washington, DC 20593-0001.
- (c) Persons who are required to identify boats under Sec. 181.23(b) must obtain the required hull identification number from the State Boating Law Administrator of the State where the boat will be principally used, or, if the State Boating Law Administrator does not assign these numbers, from the Coast Guard District office in the area of principal use.

[CGD 79-013, 48 FR 40718, Sept. 9, 1983, as amended by CGD 88-052, 53 FR 25122, July 1, 1988; CGD 96-026, 61 FR 33669, June 28, 1996]

**Sec. 181.33—Conditions for use of manufacturer identification codes**

- (a) No manufacturer or importer may sell or transfer a manufacturer identification code or use a manufacturer identification code that has been assigned to another.



(b) A manufacturer or importer who changes the business name or address must advise the Recreational Boating Product Assurance Division, 2100 Second Street SW., Washington, DC 20593-0001 of the change in writing.

[CGD 79-013, 48 FR 40718, Sept. 9, 1983, as amended by CGD 88-052, 53 FR 25122, July 1, 1988; CGD 96-026, 61 FR 33669, June 28, 1996]

**Sec. 181.35—Removal of numbers**

No person may remove or alter a number required by this subpart unless authorized by the Commandant, U.S. Coast Guard.

***Subparts D-F [Reserved]***

## CODE OF FEDERAL REGULATIONS – TITLE 33 – NAVIGATION AND NAVIGABLE WATERS

## PART 183—BOATS AND ASSOCIATED EQUIPMENT

<b>Subpart A</b>	<b>General</b>
Sec. 183.1	Purpose and applicability
Sec. 183.3	Definitions
Sec. 183.5	Incorporation by reference
<b>Subpart B</b>	<b>Display of Capacity Information</b>
Sec. 183.21	Applicability
Sec. 183.23	Capacity marking required
Sec. 183.25	Display of markings
Sec. 183.27	Construction of markings
<b>Subpart C</b>	<b>Safe Loading</b>
Sec. 183.31	Applicability.
Sec. 183.33	Maximum weight capacity: Inboard and inboard-outdrive boats
Sec. 183.35	Maximum weight capacity: Outboard boats
Sec. 183.37	Maximum weight capacity: Boats rated for manual propulsion and boats rated for outboard motors of 2 horsepower or less
Sec. 183.39	Persons capacity: Inboard and inboard-outdrive boats
Sec. 183.41	Persons capacity: Outboard boats
Sec. 183.43	Persons capacity: Boats rated for manual propulsion and boats rated for outboard motors of 2 horsepower or less
<b>Subpart D</b>	<b>Safe Powering</b>
Sec. 183.51	Applicability
Sec. 183.53	Horsepower capacity
<b>Subpart E</b>	<b>[Reserved]</b>
<b>Subpart F</b>	<b>Flotation Requirements for Inboard Boats, Inboard/Outdrive Boats, and Airboats</b>
Sec. 183.101	Applicability
Sec. 183.105	Quantity of flotation required
Sec. 183.110	Definitions
Sec. 183.112	Flotation material and air chambers
Sec. 183.114	Test of flotation materials
<b>Subpart G</b>	<b>Flotation Requirements for Outboard Boats Rated for Engines of More Than 2 Horsepower</b>
<b>GENERAL</b>	
Sec. 183.201	Applicability
Sec. 183.202	Flotation and certification requirements
Sec. 183.205	Passenger carrying area
Sec. 183.210	Reference areas
Sec. 183.215	Reference depth
Sec. 183.220	Preconditioning for tests
Sec. 183.222	Flotation material and air chambers
<b>TESTS</b>	
Sec. 183.225	Flotation test for persons capacity
Sec. 183.230	Stability test
Sec. 183.235	Level flotation test without weights for persons capacity

## **Subpart H      *Flotation Requirements for Outboard Boats Rated for Engines of 2 Horsepower or Less***

### **GENERAL**

Sec. 183.301	Applicability
Sec. 183.302	Flotation requirements
Sec. 183.305	Passenger carrying area
Sec. 183.310	Reference areas
Sec. 183.315	Reference depth
Sec. 183.320	Preconditioning for tests
Sec. 183.322	Flotation materials

### **TESTS**

Sec. 183.325	Flotation test for persons capacity
Sec. 183.330	Stability test
Sec. 183.335	Level flotation test without weights for persons capacity

**TABLE** to Subpart H of 183

**FIGURES** to Subpart H of 183

## **Subpart I      *Electrical Systems***

### **GENERAL**

Sec. 183.401	Purpose, applicability, and effective dates
Sec. 183.402	Definitions
Sec. 183.405	General

### **MANUFACTURER REQUIREMENTS**

Sec. 183.410	Ignition protection
Sec. 183.415	Grounding
Sec. 183.420	Batteries
Sec. 183.425	Conductors: General
Sec. 183.430	Conductors in circuits of less than 50 volts
Sec. 183.435	Conductors in circuits of 50 volts or more
Sec. 183.440	Secondary circuits of ignition systems
Sec. 183.445	Conductors: Protection
Sec. 183.455	Overcurrent protection: General
Sec. 183.460	Overcurrent protection: Special applications

## **Subpart J      *Fuel Systems***

### **GENERAL**

Sec. 183.501	Applicability
Sec. 183.505	Definitions
Sec. 183.507	General

### **EQUIPMENT STANDARDS**

Sec. 183.510	Fuel tanks
Sec. 183.512	Fuel tanks: Prohibited materials
Sec. 183.514	Fuel tanks: Labels
Sec. 183.516	Cellular plastic used to encase fuel tanks
Sec. 183.518	Fuel tank openings
Sec. 183.520	Fuel tank vent systems
Sec. 183.524	Fuel pumps
Sec. 183.526	Carburetors
Sec. 183.528	Fuel stop valves
Sec. 183.530	Spud, pipe, and hose fitting configuration
Sec. 183.532	Clips, straps, and hose clamps

- Sec. 183.534 Fuel filters and strainers
- Sec. 183.536 Seals and gaskets in fuel filters and strainers
- Sec. 183.538 Metallic fuel line materials
- Sec. 183.540 Hoses: Standards and markings
- Sec. 183.542 Fuel systems

#### **MANUFACTURER REQUIREMENTS**

- Sec. 183.550 Fuel tanks: Installation
- Sec. 183.552 Plastic encased fuel tanks: Installation
- Sec. 183.554 Fittings, joints, and connections
- Sec. 183.556 Plugs and fittings
- Sec. 183.558 Hoses and connections
- Sec. 183.560 Hose clamps: Installation
- Sec. 183.562 Metallic fuel lines
- Sec. 183.564 Fuel tank fill system
- Sec. 183.566 Fuel pumps: Placement
- Sec. 183.568 Anti-siphon protection
- Sec. 183.570 Fuel filters and strainers: Installation
- Sec. 183.572 Grounding

#### **TESTS**

- Sec. 183.580 Static pressure test for fuel tanks
- Sec. 183.584 Shock test
- Sec. 183.586 Pressure impulse test
- Sec. 183.588 Slosh test
- Sec. 183.590 Fire test

#### ***Subpart K***

##### ***Ventilation***

- Sec. 183.601 Applicability
- Sec. 183.605 Definitions
- Sec. 183.607 Incorporation by reference
- Sec. 183.610 Powered ventilation system
- Sec. 183.620 Natural ventilation system
- Sec. 183.630 Standards for natural ventilation

#### ***Subpart L***

##### ***Start-in-Gear Protection***

- Sec. 183.701 Applicability
- Sec. 183.705 Definitions
- Sec. 183.710 Start-in-gear protection required
- Sec. 183.715 Exception

#### ***Subpart M***

##### ***Navigation Lights***

- Sec. 183.801 Applicability
- Sec. 183.803 Definitions
- Sec. 183.810 Navigation light certification requirements

**Subpart A**

Authority: 46 U.S.C. 4302; 49 CFR 1.46. Source: CGD 72-61R, 37 FR 15782, Aug. 4, 1972, unless otherwise noted.

**General****Sec. 183.1—Purpose and applicability**

This part prescribes standards and regulations for boats and associated equipment to which 46 U.S.C. Chapter 43 applies and to which certification requirements in Part 181 of this subchapter apply.

[CGD 85-098, 52 FR 19728, May 27, 1987]

**Sec. 183.3—Definitions**

**Beam** means the transverse distance between the outer sides of the boat excluding handles, and other similar fittings, attachments, and extensions.

**Boat** means any vessel—

- (1) Manufactured or used primarily for noncommercial use;
- (2) Leased, rented, or chartered to another for the latter's noncommercial use; or
- (3) Operated as an uninspected passenger vessel subject to the requirements of 46 CFR Chapter I, Subchapter C.

**Full transom** means a transom with a maximum width which exceeds one-half the maximum beam of the boat.

**Length** means the straight line horizontal measurement of the overall length from the foremost part of the boat to the aftermost part of the boat, measured from end to end over the deck excluding sheer, and measured parallel to the centerline. Bow sprits, bumpkins, rudders, outboard motor brackets, handles, and other similar fittings, attachments, and extensions are not included in the measurement.

**Monohull** boat means a boat on which the line of intersection of the water surface and the boat at any operating draft forms a single closed curve. For example, a catamaran, trimaran, or a pontoon boat is not a monohull boat.

**Motorwell** means any arrangement of bulkheads or structures that prevents water from entering the passenger carrying area of the boat through any cutout area in the transom for mounting an outboard motor.

**Motorwell height** means the vertical distance from the lowest point of water ingress along the top of the motorwell to a line representing a longitudinal extension of the centerline of the boat's bottom surface, excluding keels. This distance is measured as a projection on the centerline plane of the boat. See Figure 183.3.

**Permanent appurtenances** means equipment that is mounted or fastened, so that it is not removable without the use of tools. Seats, inboard engines, windshields, helm stations, or hardtops are permanent appurtenances. Outboard motors, controls, batteries, and portable fuel tanks are not permanent appurtenances.

**Remote steering** means any mechanical assist device which is rigidly attached to the boat and used in steering the vessel, including but not limited to mechanical, hydraulic, or electrical control systems.

**Sailboat** means a boat designed or intended to use sails as the primary means of propulsion.

**Sheer** means the topmost line in a boat's side. The sheer intersects the vertical centerline plane of the boat at the forward end and intersects the transom (stern) at the aft end. For the purposes of this definition, the topmost line in a boat's side is the line defined by a series of points of contact with the boat structure, by straight lines at 45 degree angles to the horizontal and contained in a vertical plane normal to the outside edge of the boat as seen from above and which are brought into contact with the outside of the horizontal boat. A boat is horizontal when it is transversely level and when the lowest points at 40 percent and 75 percent of the boat's length behind the most forward point of the boat are level.

**Transom** means the surface at the stern of a boat projecting or facing aft. The upper boundary of the transom is the line defined by a series of points of contact, with the boat structure, by straight lines at 45 degree angles to the horizontal and contained in a vertical longitudinal plane and which are brought into contact with the stern of the horizontal boat. A boat is horizontal when it is transversely level and when the lowest points at 40 percent and 75 percent of the boat's length behind the most forward point of the boat are level.

**Transom height** means the vertical distance from the lowest point of water ingress along the top of the transom to a line representing a longitudinal extension of the centerline of the boat's bottom surface, excluding keels. This distance is measured as a projection on the centerline plane of the boat. See Figure 183.3.

**Vessel** includes every description of watercraft, other than a seaplane on the water, used or capable of being used as a means of transportation on the water.

**Figure 183.3—Transom and Motorwell Height**

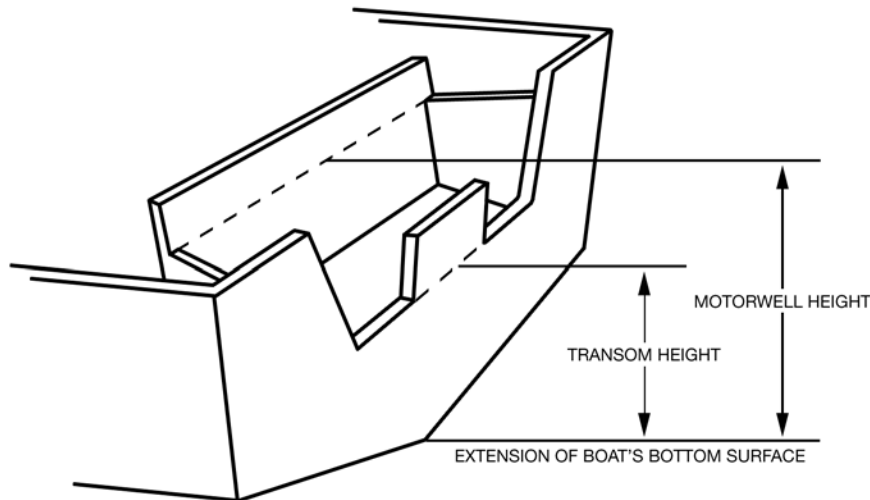

[CGD 73-250, 40 FR 43856, Sept. 23, 1975, as amended by CGD 75-176, 42 FR 2681, Jan. 13, 1977; CGD 85-002, 51 FR 37574, Oct. 23, 1986; CGD 96-026, 61 FR 33669, June 28, 1996; 61 FR 36629, July 12, 1996; USCG-1999-5040, 67 FR 34760, May 15, 2002]

### **Sec. 183.5—Incorporation by reference**

(a) Certain materials are incorporated by reference into this part with the approval of the Director of the Federal Register in accordance with 5 U.S.C. 552(a). To enforce any edition other than the one listed in paragraph (b) of this section, notice of change must be published in the Federal Register and the material made available to the public. All approved material is on file at the Office of the Federal Register, 800 North Capitol Street, NW., suite 700, Washington, DC, and

at the Recreational Boating Product Assurance Division, Washington, DC 20593-0001, and is available from the sources listed in paragraph (b) of this section.

(b) The materials approved for incorporation by reference in this part, and the sections affected are:

Air Movement and Control Association,  
30 W. University Drive, Arlington Heights, IL 60004:  
AMCA 210-74: Laboratory Methods of  
Testing Fans for Ratings—1974: Sec. 183.610.

American Society for Testing and Materials,  
100 Barr Harbor Drive, West Conshohocken, PA 19428-2959:  
ASTM D 471-96, Standard Test Method for Rubber Property—  
Effect of Liquids: Secs. 183.114; 183.516; 183.607; 183.620.  
ASTM D 1621-94, Standard Test Method for  
Compressive Properties of Rigid Cellular Plastics: Sec. 183.516.  
ASTM D 1622-93, Standard Test Method for  
Apparent Density of Rigid Cellular Plastics: Sec. 183.516.  
ASTM D 2842-97, Standard Test Method for  
Water Absorption of Rigid Cellular Plastics: Sec. 183.114.

Institute of Electrical and Electronics, Engineers, Inc.,  
445 Hoes Lane, Piscataway, NJ 08854:  
IEEE 45 IEEE Recommended Practice for  
Electrical Installations on Shipboard—1983:  
Cable Construction: Sec. 183.435.

National Fire Protection Association,  
1 Batterymarch Park, Quincy, MA 02269:  
NFPA No. 70 National Electrical Code—1987:  
Articles 310 & 400: Sec. 183.435.

Naval Publications Forms Center, Customer Service—Code 1052,  
5801 Tabor Avenue, Philadelphia, PA 19120:  
MILSPEC-P-21929B Plastic Material,  
Cellular Polyurethane, Foam-In-Place, Rigid—1970: Sec. 183.516.

Society of Automotive Engineers, Inc., 400  
Commonwealth Drive, Warrendale, PA 15096:  
SAE J378 Marine Engine Wiring—1984: Sec. 183.430.  
SAE J557 High Tension Ignition Cable—1968: Sec. 183.440.  
SAE J1127 Battery Cable—1980: Sec. 183.430.  
SAE J1128 Low Tension Primary Cable—1975: Sec. 183.430.  
SAE J1527DEC85 Marine Fuel Hoses—1985: Sec. 183.540.

Underwriters Laboratories, Inc. (UL),  
12 Laboratory Drive, Research Triangle Park, NC 27709-3995:  
UL 1114 Marine (USCG Type A)  
Flexible Fuel Line Hose—1987: Sec. 183.540.  
UL 1128 Marine Blowers—1977: Sec. 183.610.  
UL 1426 Cables for Boats—1987: Sec. 183.435.

[CGD 87-009, 53 FR 36971, Sept. 23, 1988, as amended by CGD 96-026, 61 FR 33670, June 28, 1996; USCG-1999-5151, 64 FR 67176, Dec. 1, 1999; USCG-2000-7223, 65 FR 40059, June 29, 2000]

*Effective Date Note: At 66 FR 55091, Nov. 1, 2001, Sec. 183.5 (b) was amended by adding in alphabetical order the following standard, effective Nov. 1, 2002. At 67 FR 2329, Jan. 17, 2002, the effective date was delayed until Nov. 1, 2003. For the convenience of the user the added text follows:*

**Sec. 183.5—Incorporation by reference**

- (b) American Boat and Yacht Council, Inc.,  
3069 Solomons Island Road, Edgewater, Maryland 21037-1416  
ABYC A-16 Electric Navigation Lights-1997: Sec. 183.810.

**Subpart B—Display of Capacity Information**

**Sec. 183.21—Applicability**

This subpart applies to monohull boats less than 20 feet in length, except sailboats, canoes, kayaks, and inflatable boats.

**Sec. 183.23—Capacity marking required**

Each boat must be marked in the manner prescribed in Secs. 183.25 and 183.27 with the maximum persons capacity in whole numbers of persons and in pounds, the maximum weight capacity in pounds, determined under Secs. 183.33 through 183.43, and the maximum horsepower capacity determined under Sec. 183.53 or the statement “This Boat Not Rated for Propulsion by a Motor”.

[CGD 78-034, 45 FR 2029, Jan. 10, 1980, as amended by USCG-1999-5832, 64 FR 34716, June 29, 1999]

**Sec. 183.25—Display of markings**

(a) Each marking required by Sec. 183.23 must be permanently displayed in a legible manner where it is clearly visible to the operator when getting the boat underway.

(b) The information required by Sec. 183.23 must be displayed in the following manner:

- (1) For outboard boats:
  - U.S. Coast Guard Maximum Capacities
  - XX Persons or XXX Pounds
  - XXX Pounds, persons, motor, gear
  - XXX Horsepower, motor
- or
- U.S. Coast Guard Maximum Capacities
  - XX Persons or XXX Pounds
  - XXX Pounds, persons, motor, gear
  - XXX Horsepower, motor with remote steering
  - XXX Horsepower, motor without remote steering
- (2) For inboard boats and inboard-outboard boats:
  - U.S. Coast Guard Maximum Capacities
  - XX Persons or XXX Pounds
  - XXX Pounds, persons, gear
- (3) For boats rated for motors of 2 horsepower or less:
  - U.S. Coast Guard Maximum Capacities



- XX Persons or XXX Pounds
- XXX Pounds, persons, motor, gear
- XXX Horsepower, motor
- (4) For boats rated for manual propulsion:

U.S. Coast Guard Maximum Capacities

- XX Persons or XXX Pounds
- XXX Pounds, persons, gear

This Boat Not Rated for Propulsion by Motor

(c) The capacity information displays required in paragraph (b) must meet the following as illustrated in Figure 183.25:

Figure 183.25

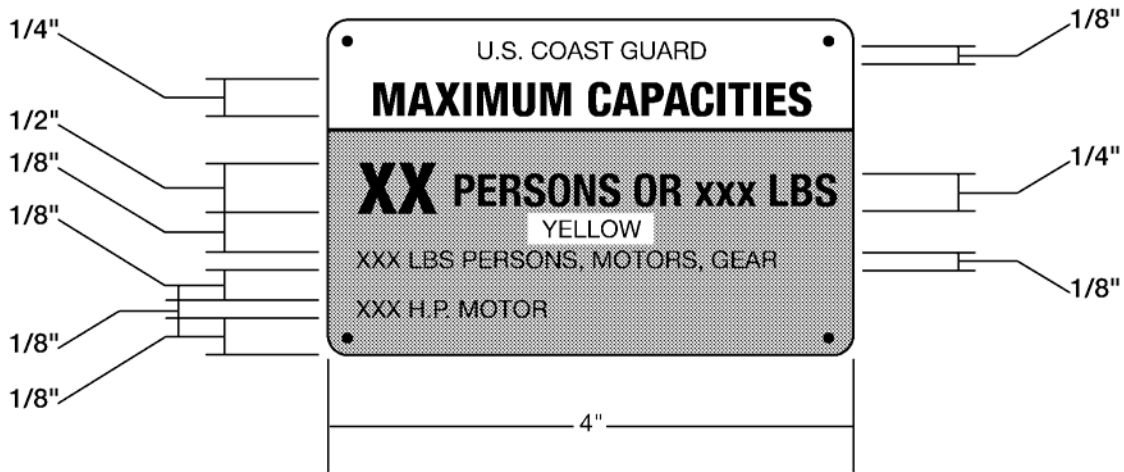

All Dimensions Are Minimum

- (1) The capacity information required in Sec. 183.23 must be displayed within a yellow area that—
  - (i) Is at least 4 inches wide; and
  - (ii) Is high enough that each line of print is separated by at least 1/8 inch from each other and from the borders of the yellow area;
- (2) The persons capacity in whole numbers must be black print with the following dimensions:
  - (i) The height must not be smaller than one-half inch;
  - (ii) The width of the numbers must be three-fifths of the height except for the number “4”, which shall be one stroke width wider, and the number “1”, which shall be one stroke in width;
  - (iii) The stroke width shall be one-sixth of the height; and
  - (iv) The minimum space between the numbers shall be one stroke width.
- (3) The words in the line “XX Persons or XXX Pounds” must be at least one-quarter inch in height but not larger than one-half the height of the persons capacity number and of a color contrasting with yellow. The number of pounds in this line must be at least one-

eighth inch in height but no larger than one-half the height of the persons capacity number and of a color contrasting with yellow.

(4) All remaining words and numbers required to be within the yellow area required in paragraph (c)(1) must be at least one-eighth inch in height, but no larger than one-half the height of the persons capacity number.

(5) All other words and numbers on the displays must be located outside the yellow area on a background color, which contrasts with yellow.

(6) The words "Maximum Capacities" must be at least one-quarter inch in height and of color contrasting with its background.

(7) The words "U.S. Coast Guard" must be at least one-eighth inch in height and of color contrasting with its background.

[CGD 78-034, 45 FR 2029, Jan. 10, 1980]

**Sec. 183.27—Construction of markings**

Each marking required by Sec. 183.23 must be—

(a) Capable of withstanding the combined effects of exposure to water, oil, salt spray, direct sunlight, heat, cold, and wear expected in normal operation of the boat, without loss of legibility; and

(b) Resistant to efforts to remove or alter the information without leaving some obvious sign of such efforts.

[CGD 78-034, 45 FR 2030, Jan. 10, 1980]

**Subpart C—Safe Loading**

**Sec. 183.31—Applicability**

This subpart applies to monohull boats less than 20 feet in length except sailboats, canoes, kayaks, and inflatable boats.

**Sec. 183.33—Maximum weight capacity: Inboard and inboard-outdrive boats**

(a) The maximum weight capacity (W) marked on a boat that has one or more inboard or inboard-outdrive units for propulsion must not exceed the greater value of W obtained from either of the following formulas:

$$W = \frac{(\text{maximum displacement})}{5} - \frac{\text{boat weight}}{5} - \frac{4(\text{machinery weight})}{5}$$

$$W = \frac{(\text{maximum displacement} - \text{boat weight})}{5}$$

(b) For the purposes of paragraph (a) of this section:

(1) Maximum displacement is the weight of the volume of water displaced by the boat at its maximum level immersion in calm water without water coming aboard. For the purpose of this paragraph, a boat is level when it is transversely level and when either of the two following conditions are met:

(i) The forward point where the sheer intersects the vertical centerline plane and the aft point where the sheer intersects the upper boundary of the transom (stern) are equidistant above the water surface or are equidistant below the water surface.

(ii) The most forward point of the boat is level with or above the lowest point of water ingress.

- (2) Boat weight is the combination of:
  - (i) Hull weight;
  - (ii) Deck and superstructure weight;
  - (iii) Weight of permanent appurtenances; and
  - (iv) Weight of full permanent fuel tanks.
- (3) Machinery weight is the combined weight of installed engines or motors, control equipment, drive units, and batteries.

[CGD 72-61R, 37 FR 15782, Aug. 4, 1972]

*Editorial Note: For Federal Register citations affecting Sec. 183.33, see the List of CFR Sections Affected, which appears in the Finding Aids section of the printed volume and on GPO Access.*

**Sec. 183.35—Maximum weight capacity: Outboard boats**

- (a) The maximum weight capacity marked on a boat that is designed or intended to use one or more outboard motors for propulsion must be a number that does not exceed one-fifth of the difference between its maximum displacement and boat weight.
- (b) For the purposes of paragraph (a) of this section:
  - (1) Maximum displacement is the weight of the volume of water displaced by the boat at its maximum level immersion in calm water without water coming aboard except for water coming through one opening in the motor well with its greatest dimension not over 3 inches for outboard motor controls or fuel lines. For the purpose of this paragraph, a boat is level when it is transversely level and when either of the two following conditions are met:
    - (i) The forward point where the sheer intersects the vertical centerline plane and the aft point where the sheer intersects the upper boundary of the transom (stern) are equidistant above the water surface or are equidistant below the water surface.
    - (ii) The most forward point of the boat is level with or above the lowest point of water ingress.
  - (2) Boat weight is the combination of:
    - (i) Hull weight;
    - (ii) Deck and superstructure weight;
    - (iii) Weight of permanent appurtenances; and
    - (iv) Weight of full permanent fuel tanks.

[CGD 72-61, 37 FR 15782, Aug. 4, 1972, as amended by CGD 73-250, 40 FR 43857, Sept. 23, 1975; CGD 75-176, 42 FR 2681, Jan. 13, 1977; USCG-1999-5832, 64 FR 34716, June 29, 1999]

**Sec. 183.37—Maximum weight capacity: Boats rated for manual propulsion and boats rated for outboard motors of 2 horsepower or less**

- (a) The maximum weight capacity marked on a boat that is rated for manual propulsion or for motors of 2 horsepower or less must not exceed 3/10 of the difference between the boat's maximum displacement and the boat's weight in pounds.
- (b) For the purposes of paragraph (a) of this section:
  - (1) Maximum displacement is the weight of the volume of water displaced by the boat at its maximum level immersion in calm water without water coming aboard. For the purpose of this paragraph, a boat is level when it is transversely level and when either of the two following conditions are met:
    - (i) The forward point where the sheer intersects the vertical centerline plane and the aft point where the sheer intersects the upper boundary of the transom (stern) are equidistant above the water surface or are equidistant below the water surface.
    - (ii) The most forward point of the boat is level with or above the lowest point of water ingress.

- (2) Boat weight is the combination of:
- (i) Hull weight;
  - (ii) Deck and superstructure weight; and
  - (iii) Weight of permanent appurtenances.

[CGD 72-61R, 37 FR 15782, Aug. 4, 1972]

*Editorial Note: For Federal Register citations affecting Sec. 183.37, see the List of CFR Sections Affected, which appears in the Finding Aids section of the printed volume and on GPO Access.*

**Sec. 183.39—Persons capacity: Inboard and inboard-outdrive boats**

- (a) The persons capacity in pounds marked on a boat that is designed to use one or more inboard engines or inboard-outdrive units for propulsion must not exceed the lesser of:
- (1) The maximum weight capacity determined under Sec. 183.33 for the boat; or
  - (2) For boats with a maximum persons capacity less than 550 pounds, the maximum persons capacity determined in the following manner:
    - (i) Float the boat in calm water with all its permanent appurtenances including installed engines, full fuel system and tanks, control equipment, drive units and batteries.
    - (ii) Gradually add weights along one outboard extremity of each passenger carrying area, at the height of the seat nearest the center of that area, but no higher than the height of the gunwale and distributed equally forward and aft of that center in a plane parallel to the floorboards, until the boat assumes the maximum list or trim or both, without water coming aboard.
    - (iii) Compute the persons capacity in pounds in the following formula: Persons capacity= $A/0.6$  where A is the total of the weights added in paragraph (a)(2)(ii) of this section.

- (b) The maximum persons capacity in whole numbers of persons marked on a boat that is designed or intended to use one or more inboard engines or inboard-outboard units must not exceed the value obtained by adding 32 pounds to the value determined in paragraph (a)(2)(iii), dividing the sum by 141 and rounding off the result to the nearest whole number. If the fraction is less than one-half, round down to the next whole integer and if the fraction is equal to or greater than one-half, round up to the next higher whole integer.

[CGD 78-034, 45 FR 2030, Jan. 10, 1980, as amended by CGD 83-012, 49 FR 39328, Oct. 5, 1984; 50 FR 18636, May 2, 1985]

**Sec. 183.41—Persons capacity: Outboard boats**

- (a) The persons capacity in pounds marked on a boat that is designed to use one or more outboard motors for propulsion must not exceed the lesser of:
- (1) The maximum weight capacity determined under Sec. 183.35 for the boat minus the motor and control weight, battery weight (dry), and full portable fuel tank weight from Table 4 of Subpart H of this part; or
  - (2) For boats with a maximum persons capacity less than 550 pounds, the maximum persons capacity determined in the following manner:
    - (i) Float the boat with all its permanent appurtenances.
    - (ii) Add, in normal operating positions, the dry motor and control weight, battery weight, and full portable fuel tank weight, if any, shown in Table 4 of Subpart H of this part for the maximum horsepower capacity marked on the boat. Permanently installed fuel tanks shall be full of fuel.
    - (iii) Gradually add weights along one outboard extremity of each passenger carrying area, at the height of the seat nearest the center of that area, but no higher than the height of the gunwale, and distributed equally forward and aft of

that center in a plane parallel to the floorboards until the boat assumes the maximum list or trim, or both without water coming aboard.

(iv) Compute the persons capacity in pounds using the following formula: Persons capacity= $A/0.6$  where A is the total of the weights added in paragraph (a)(2)(iii) of this section.

(b) The maximum persons capacity in whole numbers of persons marked on a boat designed or intended to use one or more outboard motors for propulsion must not exceed the value obtained by adding 32 pounds to the lesser of the values determined in paragraph (a)(1) or (a)(2)(iv), dividing the sum by 141, and rounding off the result to the nearest whole number. If the fraction is less than one-half, round down to the next lower whole integer and if the fraction is equal to or greater than one-half, round up to the next higher whole integer.

[CGD 78-034, 45 FR 2030, Jan. 10, 1980, as amended by CGD 83-012, 49 FR 39328, Oct. 5, 1984; 50 FR 18636, May 2, 1985]

**Sec. 183.43—Persons capacity: Boats rated for manual propulsion and boats rated for outboard motors of 2 horsepower or less**

(a) The persons capacity in pounds marked on a boat that is rated for manual propulsion or for motors of 2 horsepower or less must not exceed:

- (1) For boats rated for manual propulsion, 90 percent of the maximum weight capacity in pounds; and
- (2) For boats rated for motors of 2 horsepower or less, 90 percent of the maximum weight capacity in pounds, less 25 pounds.

(b) The maximum persons capacity, in whole numbers of persons marked on a boat that is rated for manual propulsion must not exceed the value obtained by adding 32 pounds to the value determined in paragraph (a)(1), dividing the sum by 141, and rounding off the result to the nearest whole number. If the fraction is less than one-half, round down to the next lower integer and if the fraction is equal to or greater than one-half, round up to the next higher whole integer.

(c) The maximum persons capacity in whole numbers of persons marked on a boat rated for motors of 2 horsepower or less must not exceed the value obtained by adding 32 pounds to the value determined in paragraph (a)(2), dividing the sum by 141, and rounding off the result to the nearest whole number. If the fraction is less than one-half, round down to the next lower whole integer and if the fraction is equal to or greater than one-half, round up to the next higher whole integer.

[CGD 78-034, 45 FR 2031, Jan. 10, 1980]

**Subpart D—Safe Powering**

**Sec. 183.51—Applicability**

This subpart applies to monohull boats less than 20 feet in length, except sailboats, canoes, kayaks, and inflatable boats, that are designed or intended to use one or more outboard motors for propulsion.

**Sec. 183.53—Horsepower capacity**

The maximum horsepower capacity marked on a boat must not exceed the horsepower capacity determined by the computation method discussed in paragraph (a) of this section, or for certain qualifying boats, the performance test method discussed in paragraph (b) of this section.

(a) The maximum horsepower capacity must be computed as follows:

- (1) Compute a factor by multiplying the boat length in feet by the maximum transom width in feet excluding handles and other similar fittings, attachments, and extensions. If the boat does not have a full transom, the transom width is the broadest beam in the aftermost quarter length of the boat.
- (2) Locate horsepower capacity corresponding to the factor in Table 183.53.
- (3) For a boat with a factor over 52.5, if the horsepower capacity calculated in Table 183.53 is not an exact multiple of 5, it may be raised to the next exact multiple of 5.
- (4) For flat bottom hard chine boats with a factor of 52 or less, the horsepower capacity must be reduced by one horsepower capacity increment in Table 183.53.

**Table 183.53—Outboard Boat Horsepower Capacity**

[Compute: Factor = Boat Length X Transom Width]

<b>If factor (nearest integer) is</b>	0-35	36-39	40-42	43-45	46-52
<b>Horsepower Capacity is</b>	3	5	7.5	10	15

[Note: For flat bottom hard chine boats, with factor of 52 or less, reduce one capacity limit (e.g. 5 to 3)]

If factor is over 52.5 and the boat has	Remote steering and at least 20[sec] transom	No remote steering, or less than 20[sec] transom height	
		For flat bottom hard chine boats	For other boats
Horsepower capacity is (raise to nearest multiple of 5).	(2 X Factor)-90	(0.5 X Factor)-15	(0.8 X Factor)-25

(b) For boats qualifying under this paragraph, the performance test method described in this paragraph may be used to determine the horsepower capacity.

- (1) Qualifying criteria.
  - (i) Thirteen feet or less in length;
  - (ii) Remote wheel steering;
  - (iii) Transom height
    - (A) Minimum 19 inch transom height; or,
    - (B) For boats with at least a 19 inch motorwell height, a minimum 15 inch transom height;
  - (iv) Maximum persons capacity not over two persons;
- (2) Boat preparation.
  - (i) The boat must be rigged with equipment recommended or provided by the boat and motor manufacturer and tested with the highest horsepower production powerplant for which the boat is to be rated, not to exceed 40 horsepower.
  - (ii) Standard equipment must be installed in accordance with manufacturers' instructions.
  - (iii) The lowest ratio (quickest) steering system offered on the boat model being tested must be installed.
  - (iv) The outboard motor must be fitted with the manufacturer's recommended propeller providing maximum speed.
  - (v) Standard permanently installed fuel tanks must be no more than one-half full. Boats without permanent tanks must be tested with one full portable tank.
  - (vi) Portable tanks must be in their designated location or placed as far aft as possible.
  - (vii) The outboard motor must be placed in the lowest vertical position on the transom or, if mounting instructions are provided with the boat, at the height recommended.
  - (viii) Boat bottom, motor and propeller must be in new or almost new condition.

*Note: The use of the following special equipment should be considered because of the potential for exceeding the capabilities of the boat while performing the test: Racing Type Personal Flotation Device Helmet.*

(3) Test conditions. Testing must be conducted on smooth, calm water with the wind speed below 10 knots. The test must be conducted with no load other than a driver who must weigh no more than 200 pounds. The motor trim angle must be adjusted to provide maximum full throttle speed short of excessive porpoising or propeller ventilation or "cavitation", so that there is no loss of directional control.

(4) Quick turn test procedure. Set throttle at a low maneuvering speed and steer the boat straight ahead. Turn the steering wheel 180 deg. in the direction of least resistance in 1/2 second or less and hold it at that position without changing the throttle or trim settings during or after the wheel change. The boat completes the maneuver successfully if it is capable of completing a 90 deg. turn without the driver losing control of the boat or reducing the throttle setting. Gradually increase the boat's turn entry speed incrementally until the boat does not complete the Quick Turn Test successfully or successfully completes it at maximum throttle.

*Note: It is recognized that operator skill and familiarity with a particular boat and motor combination will affect the test results. It is permissible to make a number of practice runs through the quick turn test at any throttle setting.*

(5) Test course method. Set throttle for 30 miles per hour boat speed and run the test course set up in accordance with Figure 183.53, passing outside the designated avoidance marker for 35 to 37.5 miles per hour without contacting any of the course markers. If the boat successfully completes this run of the test course, increase the throttle setting to 35 to 37.5 miles per hour boat speed and run the course passing outside the designated avoidance marker for that speed without contacting any of the course markers. If the boat successfully completes this run of the test course and the motor was not at full throttle, increase the throttle setting to 37.5 to 42.5 miles per hour boat speed and run the course passing outside the designated avoidance marker for that speed without contacting any of the course markers. If the boat successfully completes this run of the test course and the motor was not at full throttle, increase the throttle setting to 42.5 miles per hour or more and run the course passing outside the designated avoidance marker for that speed without contacting any of the course markers. If the boat successfully completes this run of the test course and the motor was not at full throttle, continue to increase the throttle setting and run the test course passing outside the designated avoidance marker for 42.5 miles per hour or more until the boat fails to complete the test successfully or the boat completes the test course maneuvers successfully at full throttle. The boat successfully completes the test course if the driver is able to maneuver it between the designated avoidance markers without striking the markers and without losing control of the boat or reducing the throttle setting. There must be no change in position of any equipment on board and there must be no change of position of personnel in order to influence the test results. There must be no instability evidenced by oscillating motion in the roll or yaw axes exhibited while negotiating the course.

*Note: It is recognized that operator skill and familiarity with a particular boat and motor combination will affect the test results. It is therefore considered permissible to make a number of practice runs through the test course at any throttle setting.*

(6) Maximum horsepower capacity.

(i) For boats capable of less than 35 miles per hour, the maximum horsepower capacity must be the maximum horsepower with which the boat was able to successfully complete the Quick Turn Test Procedure in Sec. 183.53(b)(4) at full throttle or the maximum horsepower determined under the calculations in Sec. 183.53(a) of this section.

(ii) For boats capable of 35 miles per hour or more, the maximum horsepower capacity must be the maximum horsepower with which the boat was able to successfully complete both the Quick Turn Test Procedure in Sec. 183.53(b)(4) and the Test Course Method in Sec. 183.53(b)(5) at full throttle or the calculations

in Sec. 183.53(a) of this section.(iii) The maximum horsepower capacity determined in accordance with Sec. 183.53(b) must not exceed 40 horsepower.

**Figure 183.53—Boat Horsepower Capacity Test Course—35 MPH or More**

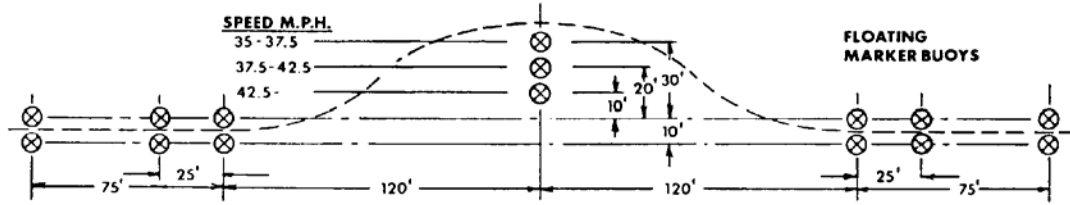

[CGD 85-002, 51 FR 37574, Oct. 23, 1986]

**Subpart E [Reserved]**

**Subpart F—Flotation Requirements for Inboard Boats, Inboard/Outdrive Boats, and Airboats**

Source: CGD 75-168, 42 FR 20243, Apr. 18, 1977, unless otherwise noted.

**Sec. 183.101—Applicability**

This subpart applies to monohull inboard boats, inboard/outdrive boats, and airboats less than 20 feet in length, except sailboats, canoes, kayaks, inflatable boats, submersibles, surface effect vessels, amphibious vessels, and raceboats.

[CGD 75-168, 42 FR 20243, Apr. 18, 1977, as amended by USCG-1999-5832, 64 FR 34716, June 29, 1999]

**Sec. 183.105—Quantity of flotation required**

- (a) Each boat must have enough flotation to keep any portion of the boat above the surface of the water when the boat has been submerged in calm, fresh water for at least 18 hours and loaded with:
  - (1) A weight that, when submerged, equals two-fifteenths of the persons capacity marked on the boat;
  - (2) A weight that, when submerged, equals 25 percent of the dead weight; and
  - (3) A weight in pounds that, when submerged, equals 62.4 times the volume in cubic feet of the two largest air chambers, if air chambers are used for flotation.
- (b) For the purpose of this section, “dead weight” means the maximum weight capacity marked on the boat minus the persons capacity marked on the boat.

**Sec. 183.110—Definitions**

For the purpose of this subpart:

Bilge means the area in the boat, below a height of 4 inches measured from the lowest point in the boat where liquid can collect when the boat is in its static floating position, except engine rooms.

Connected means allowing a flow of water in excess of one-quarter ounce per hour from the engine room bilge into any other compartment with a 12 inch head of water on the engine room side of the bulkhead.



Engine room bilge means the area in the engine room or a connected compartment below a height of 12 inches measured from the lowest point where liquid can collect in these compartments when the boat is in its static floating position.

Engine room means the compartment where a permanently installed gasoline or diesel engine is installed, including connected compartments.

Open to atmosphere means a compartment that has at least 15 square inches of open area directly exposed to the atmosphere for each cubic foot of net compartment volume.

Sealed compartment means an enclosure that can resist an exterior water level of 12 inches without seepage of more than one-quarter fluid ounce per hour.

[CGD 77-145, 43 FR 56858, Dec. 4, 1978, as amended by CGD 82-010, 48 FR 8273, Feb. 28, 1983; CGD 85-098, 52 FR 19728, May 27, 1987; CGD 96-026, 61 FR 33670, June 28, 1996; USCG-1999-5832, 64 FR 34716, June 29, 1999; USCG-1999-5151, 64 FR 67176, Dec. 1, 1999]

**Sec. 183.112—Flotation material and air chambers**

(a) Flotation materials must meet the requirements in Sec. 183.114 as listed in Table 183.114 when used in the: (1) Engine room bilge, (2) engine room, or (3) bilge, unless located in a sealed compartment.

(b) Air chambers used to meet the flotation requirements of this subpart must not be integral with the hull.

[CGD 77-145, 43 FR 56859, Dec. 4, 1978; 44 FR 47934, Aug. 16, 1979]

**Sec. 183.114—Test of flotation materials**

(a) Vapor test. The flotation material must not reduce in buoyant force more than 5 percent after being immersed in a fully saturated gasoline vapor atmosphere for 30 days at a minimum temperature of 38 deg. C.

(b) 24-hour gasoline test. The flotation material must not reduce in buoyant force more than 5 percent after being immersed for 24 hours at 23 plus or minus 2 deg. C in reference fuel B, of ASTM D 471 (incorporated by reference, see Sec. 183.5).

(c) 30-day gasoline test. The flotation material must not reduce in buoyant force more than 5 percent after being immersed for 30 days at 23 plus or minus 2 deg. C in reference fuel B, of ASTM D 471 (incorporated by reference, see Sec. 183.5).

(d) 24-hour oil test. The flotation material must not reduce in buoyant force more than 5 percent after being immersed for 24 hours at 23 plus or minus 2 deg. C in reference oil No. 2, of ASTM D 471 (incorporated by reference, see Sec. 183.5).

(e) 30-day oil test. The flotation material must not reduce in buoyant force more than 5 percent after being immersed for 30 days at 23 plus or minus 2 deg. C in reference oil No. 2, of ASTM D 471 (incorporated by reference, see Sec. 183.5).

(f) 24-hour bilge cleaner test. The flotation material must not reduce in buoyant force more than 5 percent after being immersed for 24 hours at 23 plus or minus 2 deg. C in a 5-percent solution of trisodium phosphate in water.

(g) 30-day bilge cleaner test. The flotation material must not reduce in buoyant force more than 5 percent after being immersed for 30 days at 23 plus or minus 2 deg. C in a 5-percent solution of trisodium phosphate in water.

(h) The buoyant force reduction in paragraphs (a) through (g) of this section is measured in accordance with ASTM D 2842 (incorporated by reference, see Sec. 183.5).

**Table 183.114—Flotation Performance Tests**

Test 183.114	Area 183.110		
	(b) Engine-room bilge	(c) Engine-room unless open to atmosphere	(d) Bilge
(a) Vapor test		X	
(b) 24 hour gasoline test			X
(c) 30 day gasoline test	X		
(d) 24 hour oil test			X
(e) 30 day oil test	X		
(f) 24 hour bilge cleaner test			X
(g) 30 day bilge cleaner test	X		

[CGD 77-145, 43 FR 56859, Dec. 4, 1978; 44 FR 47934, Aug. 16, 1979, as amended by USCG-2000-7223, 65 FR 40059, June 29, 2000]

**Subpart G—Flotation Requirements for Outboard Boats Rated for Engines of More Than 2 Horsepower**

Source: CGD 75-168, 42 FR 20243, Apr. 18, 1977, unless otherwise noted.

**GENERAL**

**Sec. 183.201—Applicability**

- (a) This subpart applies to monohull outboard boats that are:
- (1) Less than 20 feet in length; and
  - (2) Rated for outboard engines of more than 2 horsepower.

(b) This subpart does not apply to sailboats, canoes, kayaks, inflatable boats, submersibles, surface effect vessels, amphibious vessels, and raceboats.

[CGD 75-168, 42 FR 20243, Apr. 18, 1977, as amended by USCG-1999-5832, 64 FR 34716, June 29, 1999]

**Sec. 183.202—Flotation and certification requirements**

Each boat to which this subpart applies must be manufactured, constructed, or assembled to pass the stability and flotation tests prescribed in Secs. 183.225(a), 183.230(a), and 183.235(a).

**Sec. 183.205—Passenger carrying area**

(a) For the purpose of this section a boat is level when it is supported on its keel at the two points shown in Figure 2.

(b) As used in this subpart, the term “passenger carrying area” means each area in a boat in which persons can sit in a normal sitting position or stand while the boat is in operation. Passenger carrying areas are illustrated in Figures 3 through 8.

(c) The length of the passenger carrying area is the distance along the centerline of the boat between two vertical lines, one at the forward end and one at the aft end of the passenger carrying area when the boat is level as illustrated in Figures 3 and 4. For boats with a curved stem inside the passenger carrying area, the forward vertical line is where a line 45 degrees to the horizontal when the boat is level is tangent to the curve of the stem, as illustrated in Figure 5. For boats with cabins, the forward vertical line is where there is a minimum distance of two feet between the inside top of the cabin and the water line formed when the boat is swamped and loaded with weights under Sec. 183.220 as illustrated in Figure 6.

(d) The breadth of each passenger carrying area is the distance between two vertical lines at the mid-length, excluding consoles, of the passenger carrying area when the boat is level as illustrated in Figures 7 and 8. For boats with round chines inside the passenger carrying area, the vertical line is where a transverse line 45 degrees to the horizontal is tangent to the arc of the chine, as illustrated in Figure 8.

[CGD 75-168, 42 FR 20243, Apr. 18, 1977, as amended by USCG-1999-5832, 64 FR 34716, June 29, 1999]

**Sec. 183.210—Reference areas**

(a) The forward reference area of a boat is the forward most 2 feet of the top surface of the hull or deck, as illustrated in Figure 9.

(b) The aft reference area of a boat is the aft most two feet of the top surface of the hull or deck, as illustrated in Figure 9.

**Sec. 183.215—Reference depth**

Reference depth is the minimum distance between the uppermost surface of the submerged reference area of a boat and the surface of the water measured at the centerline of the boat, as illustrated in Figure 10. If there is no deck surface at the centerline of the boat from which a measurement can be made, the reference depth is the average of two depth measurements made on opposite sides of, and at an equal distance from, the centerline of the boat.

**Sec. 183.220—Preconditioning for tests**

A boat must meet the following conditions for at least 18 hours before the tests required by Secs. 183.225, 183,230, and 183.235:

(a) Manufacturer supplied permanent appurtenances such as windshields and convertible tops must be installed on the boat.

(b) The boat must be loaded with a quantity of weight that, when submerged, is equal to the sum of the following:

(1) The sum of 50 percent of the first 550 pounds of the persons capacity marked on the boat and 12-1/2 percent of the remainder of the persons capacity.

(2) Twenty-five percent of the result of the following calculation, but not less than zero: The maximum weight capacity marked on the boat; less the weight shown in Column 6 of Table 4 for maximum horsepower marked on the boat; less the persons capacity marked on the boat.

(c) The weights required by paragraph (b) of this section must be placed in the boat so that the center of gravity of each amount of weight required by paragraphs (b)(1) and (b)(2) of this section is within the shaded area illustrated in Figure 11. The location and dimensions of the shaded area are as follows:

(1) The shaded area is centered at the mid-length of the passenger carrying area and at the mid-breadth of the boat;

- (2) The length of the shaded area, measured along the centerline of the boat, is equal to 40 percent of the length of the passenger carrying area of the boat; and
- (3) The breadth of the shaded area, measured at the midlength of the passenger carrying area, is equal to 40 percent of the breadth of the passenger carrying area of the boat.

(d) Weight must be placed in the normal operating position of the motor and controls and the battery in lieu of this equipment. The required quantity of weight used for this purpose depends upon the maximum rated horsepower of the boat being tested and is specified in Columns 2 and 4 of Table 4 for the swamped weight of the motor and controls and for the submerged weight or the battery, respectively.

(e) Permanent fuel tanks must be filled with fuel and each external opening into the fuel tank must be sealed.

(f) The boat must be keel down in the water.

(g) The boat must be swamped, allowing water to flow between the inside and outside of the boat, either over the sides, through a hull opening, or both. Entrapped air in the flooded portion of the boat must be eliminated.

(h) Water must flood the two largest air chambers and all air chambers integral with the hull.

[CGD 75-168, 42 FR 20243, Apr. 18, 1977, as amended by USCG-1999-5832, 64 FR 34716, June 29, 1999]

**Sec. 183.222—Flotation material and air chambers**

(a) Flotation materials must meet the requirements in Sec. 183.114 as listed in Table 183.114 when used in the bilge, unless located in a sealed compartment.

(b) Air chambers used to meet the flotation requirements of this subpart must not be integral with the hull.

[CGD 77-145, 43 FR 56859, Dec. 4, 1978; 44 FR 47934, Aug. 16, 1979]

**TESTS**

**Sec. 183.225—Flotation test for persons capacity**

Flotation standard. When the conditions prescribed in Sec. 183.220 are met, the boat must float in fresh, calm water as follows:

- (a) The angle of heel does not exceed 10 degrees from the horizontal.
- (b) Any point on either the forward or aft reference area is above the surface of the water.
- (c) The reference depth at the reference area that is opposite the reference area that is above the surface of the water is 6 inches or less.

**Sec. 183.230—Stability test**

(a) Flotation standard. When the conditions prescribed in Sec. 183.220 (a), (d) through (h) and paragraphs (b) and (c) of this section are met, the boat must float in fresh, calm water as follows:

- (1) The angle of heel does not exceed 30 degrees from the horizontal.
- (2) Any point on either the forward or aft reference area is above the surface of the water.
- (3) The reference depth at the reference area that is opposite the reference area that is above the surface of the water is 12 inches or less.

- (b) Quantity of weight used. Load the boat with a quantity of weight that, when submerged, is equal to the sum of the following:
- (1) One-half of the quantity of weight required by Sec. 183.220(b)(1).
  - (2) The quantity of weight required by Sec. 183.220(b)(2).
- (c) Placement of quantity of weight: starboard side. Place the weight required by paragraph (b) of this section in the boat so that:
- (1) The quantity of weight required by Sec. 183.220(b)(2) is positioned in accordance with Sec. 183.220(c); and
  - (2) One-half the quantity of weight required by Sec. 183.220(b)(1) is uniformly distributed over a distance along the outboard perimeter of the starboard side of the passenger carrying area that is equal to at least 30 percent of the length of the passenger carrying area so that the center of gravity of the quantity of weight is located within the shaded area illustrated in Figure 12, the center of gravity of the amount of weight placed on the floor of the boat is at least 4 inches above the floor, and the center of gravity of the amount of weight placed on a seat is at least 4 inches above the seat. The location and dimensions of the shaded area are as follows:
    - (i) The shaded area is centered at the mid-length of the passenger carrying area;
    - (ii) The length of the shaded area is equal to 70 percent of the length of the passenger carrying area; and
    - (iii) The breadth of the shaded area is 6 inches from:
      - (A) For weights placed on the floor, the outboard perimeter of the passenger carrying area; and
      - (B) For weights placed on a seat, a vertical line inside the passenger carrying area as illustrated in Figure 13.
- (d) Placement of quantity of weight: port side. The quantity of weight required by paragraph (b)(1) of this section is placed along the port side of the passenger carrying area in accordance with the conditions prescribed in paragraph (c)(2) of this section.

**Sec. 183.235—Level flotation test without weights for persons capacity**

When the conditions prescribed in Sec. 183.220 (a) and (d) through (h) are met, the boat must float in fresh, calm water as follows:

- (a) The angle of heel does not exceed 10 degrees from the horizontal.
- (b) Any point on either the forward or aft reference area is above the surface of the water.
- (c) The reference depth at the reference area that is opposite the reference area that is above the surface of the water is 6 inches or less.

[CGD 77-145, 43 FR 56859, Dec. 4, 1978, as amended by USCG-1999-5832, 64 FR 34716, June 29, 1999]

**Subpart H—Flotation Requirements for Outboard Boats Rated for Engines of 2 Horsepower or Less**

Source: CGD 75-168, 42 FR 20245, Apr. 18, 1977, unless otherwise noted.

**GENERAL**

**Sec. 183.301—Applicability**

- (a) This subpart applies to monohull outboard boats that are:
  - (1) Less than 20 feet in length; and
  - (2) Rated for manual propulsion or outboard engines of 2 horsepower or less.

(b) This subpart does not apply to sailboats, canoes, kayaks, inflatable boats, submersibles, surface effect vessels, amphibious vessels, and raceboats.

[CGD 75-168, 42 FR 20245, Apr. 18, 1977, as amended by USCG-1999-5832, 64 FR 34716, June 29, 1999]

**Sec. 183.302—Flotation requirements**

Each boat to which this subpart applies must be manufactured, constructed, or assembled to pass the stability and flotation tests prescribed in Secs. 183.325(a), 183.330(a), and 183.335(a).

**Sec. 183.305—Passenger carrying area**

(a) For the purpose of this section, a boat is level when it is supported on its keel at the two points shown in Figure 2.

(b) As used in this subpart, the term “passenger carrying area” means each area in a boat in which persons can sit in a normal sitting position or stand while the boat is in operation. Passenger carrying areas are illustrated in Figures 3 through 8.

(c) The length of each passenger carrying area is the distance along the centerline of the boat between two vertical lines, one at the forward end and one at the aft end of the passenger carrying area, when the boat is level, as illustrated in Figures 3 and 4. For boats with a curved stem inside the passenger carrying area, the forward vertical line is where a line 45 degrees to the horizontal when the boat is level is tangent to the curve of the stem, as illustrated in Figure 5. For boats with cabins, the forward vertical line is where there is a minimum distance of two feet between the inside top of the cabin and the water line formed when the boat is swamped and loaded with weights under Sec. 183.320 as illustrated in Figure 6.

(d) The breadth of the passenger carrying area is the distance between two vertical lines at the mid-length, excluding consoles, of the passenger carrying area when the boat is level as illustrated in Figures 7 and 8. For boats with round chines inside the passenger carrying area, the vertical line is where a transverse line 45 degrees to the horizontal is tangent to the arc of the chine, as illustrated in Figure 7.

[CGD 75-168, 42 FR 20245, Apr. 18, 1977; 42 FR 24738, May 16, 1977]

**Sec. 183.310—Reference areas**

(a) The forward reference area of a boat is the forwardmost 2 feet of the top surface of the hull or deck as illustrated in Figure 9.

(b) The aft reference area of a boat is the aftmost two feet of the top surface of the hull or deck, as illustrated in Figure 9.

**Sec. 183.315—Reference depth**

Reference depth is the minimum distance between the uppermost surface of the submerged reference area of a boat and the surface of the water measured at the centerline of the boat, as illustrated in Figure 10. If there is no deck surface at the centerline of the boat from which a measurement can be made, the reference depth is the average of two depth measurements made on opposite sides of, and at an equal distance from, the centerline of the boat.

**Sec. 183.320—Preconditioning for tests**

A boat must meet the following conditions for at least 18 hours before the tests required by Secs. 183.325, 183.330, and 183.335:

- (a) Manufacturer supplied permanent appurtenances such as windshields, and convertible tops must be installed on the boat.
- (b) The boat must be loaded with a quantity of weight that, when submerged, is equal to the sum of the following:
  - (1) Two-fifteenths of the persons capacity marked on the boat.
  - (2) Twenty-five percent of the result of the following calculation, but not less than zero: the maximum weight capacity marked on the boat; less the weight shown in column 6 of Table 4 for the maximum horsepower marked on the boat; less the persons capacity marked on the boat.
- (c) The weights required by paragraph (b) of this section are placed in the boat so that the center of gravity of each amount of weight required by paragraphs (b)(1) and (b)(2) of this section is within the shaded area illustrated in Figure 11. The location and dimensions of the shaded area are as follows:
  - (1) The shaded area is centered at the mid-length of the passenger carrying area and at the mid-breadth of the boat;
  - (2) The length of the shaded area, measured along the centerline of the boat, is equal to 40 percent of the length of the passenger carrying area of the boat; and
  - (3) The breadth of the shaded area, measured at the mid-length of the passenger carrying area, is equal to 40 percent of the breadth of the passenger carrying area of the boat.
- (d) Weight must be placed in the normal operating position of the motor and controls in lieu of this equipment. The quantity of weight used for this purpose depends upon the maximum rated horsepower of the boat being tested and is specified in Column 2 of Table 4 for the swamped weight of the motor and controls.
- (e) Permanent fuel tanks must be filled with fuel and each external opening into the fuel tank must be sealed.
- (f) The boat must be keel down in the water.
- (g) The boat must be swamped, allowing water to flow between the inside and the outside of the boat, either over the sides, through a hull opening, or both. Entrapped air in the flooded portion of the boat must be eliminated.

**Sec. 183.322—Flotation materials**

- (a) Flotation materials must meet the requirements in Sec. 183.114 as listed in Table 183.114 when used in the bilge, unless located in a sealed compartment.

[CGD 77-145, 43 FR 56859, Dec. 4, 1978; 44 FR 47934, Aug. 16, 1979]

**TESTS**

**Sec. 183.325—Flotation test for persons capacity**

Flotation standard. When the conditions prescribed in Sec. 183.320 are met, the boat must float in fresh, calm water as follows:

- (a) The angle of heel does not exceed 10 degrees from the horizontal.
- (b) Any point on either the forward or aft reference area is above the surface of the water.
- (c) The reference depth at the reference area that is opposite the reference area that is above the surface of the water is 6 inches or less.

**Sec. 183.330—Stability test**

(a) Flotation standard. When the conditions prescribed in Sec. 183.320 (a), (d) through (g) and paragraphs (b) and (c) of this section are met, the boat must float in fresh, calm water as follows:

- (1) The angle of heel does not exceed 30 degrees from the horizontal.
- (2) Any point on either the forward or aft reference area is above the surface of the water.
- (3) The reference depth at the reference area that is opposite the reference area that is above the surface of the water is 12 inches or less.

(b) Quantity of weight used. Load the boat with quantity of weight that, when submerged, is equal to the sum of the following:

- (1) One-half the quantity of weight required by Sec. 183.320(b)(1).
- (2) The quantity of weight required by Sec. 183.320(b)(2).

(c) Placement of quantity of weight: starboard side. Place the quantity of weight required by paragraph (b) of this section in the boat so that:

- (1) The quantity of weight required by Sec. 183.320(b)(2) is positioned in accordance with Sec. 183.320(c); and
- (2) One-half the quantity of weight required by Sec. 183.320(b)(1) is uniformly distributed over a distance along the outboard perimeter of the starboard side of the passenger carrying area that is equal to at least 30 percent of the length of the passenger carrying area so that the center of gravity of the quantity of weight is located within the shaded area illustrated in Figure 12, the center of gravity of the amount of weight placed on the floor of the boat is at least 4 inches above the floor and the center of gravity of the amount of weight placed on a seat is at least 4 inches above the seat. The location and dimensions of the shaded area are as follows:
  - (i) The shaded area is centered at the mid-length of the passenger carrying area;
  - (ii) The length of the shaded area is equal to 70 percent of the length of the passenger carrying area; and
  - (iii) The breadth of the shaded area is 6 inches from:
    - (a) For weights placed on the floor, the outboard perimeter of the passenger carrying area; and
    - (b) For weights placed on a seat, a vertical line inside the passenger carrying area as illustrated in Figure 13.

(d) Placement of quantity of weight: port side. The quantity of weight required by paragraph (b)(1) of this section is placed along the port side of the passenger carrying area in accordance with the conditions prescribed in paragraph (c)(2) of this section.

**Sec. 183.335—Level flotation test without weights for persons capacity**

When the conditions prescribed in Sec. 183.320 (a) and (d) through (g) are met, the boat must float in fresh, calm water as follows:

- (a) The angle of heel does not exceed 10 degrees from the horizontal.
- (b) Any point on either the forward or aft reference area is above the surface of the water.
- (c) The reference depth at the reference area that is opposite the reference area that is above the surface of the water is 6 inches or less.

[CGD 75-168, 42 FR 20245, Apr. 18, 1977, as amended by USCG-1999-5832, 64 FR 34716, June 29, 1999]



**Table 4—Weights (Pounds) of Outboard Motor and Related Equipment for Various Boat Horsepower Ratings**

Boat horsepower rating	Motor and control weight		Battery weight		Full portable fuel tank weight	1+3+5
	Dry	Swamped	Dry	Swamped		
	Column No.					
	1	2	3	4	5	6
0.1 to 2	25	20	.....	.....	.....	25
2.1 to 4	40	34	.....	.....	.....	40
4.1 to 7	60	52	.....	.....	25	35
7.1 to 15	90	82	20	11	50	160
15.1 to 25	125	105	45	25	50	220
25.1 to 45	170	143	45	25	100	315
45.1 to 60	235	195	45	25	100	380
60.1 to 80	280	235	45	25	100	425
80.1 to 145	405	352	45	25	100	550
145.1 to 275	430	380	45	25	100	575
275.1 and up	605	538	45	25	100	750
Transoms designed for twin motors						
50.1 to 90	340	286	90	50	100	530
90.1 to 120	470	390	90	50	100	660
120.1 to 160	560	470	90	50	100	750
160.1 to 290	810	704	90	50	100	1000
290.1 to 550	860	760	90	50	100	1050
550.1 and up	1210	1076	90	50	100	1400

[CGD 83-012, 49 FR 39328, Oct. 5, 1984]

**Figure 2—Location of Support for Level Boat**

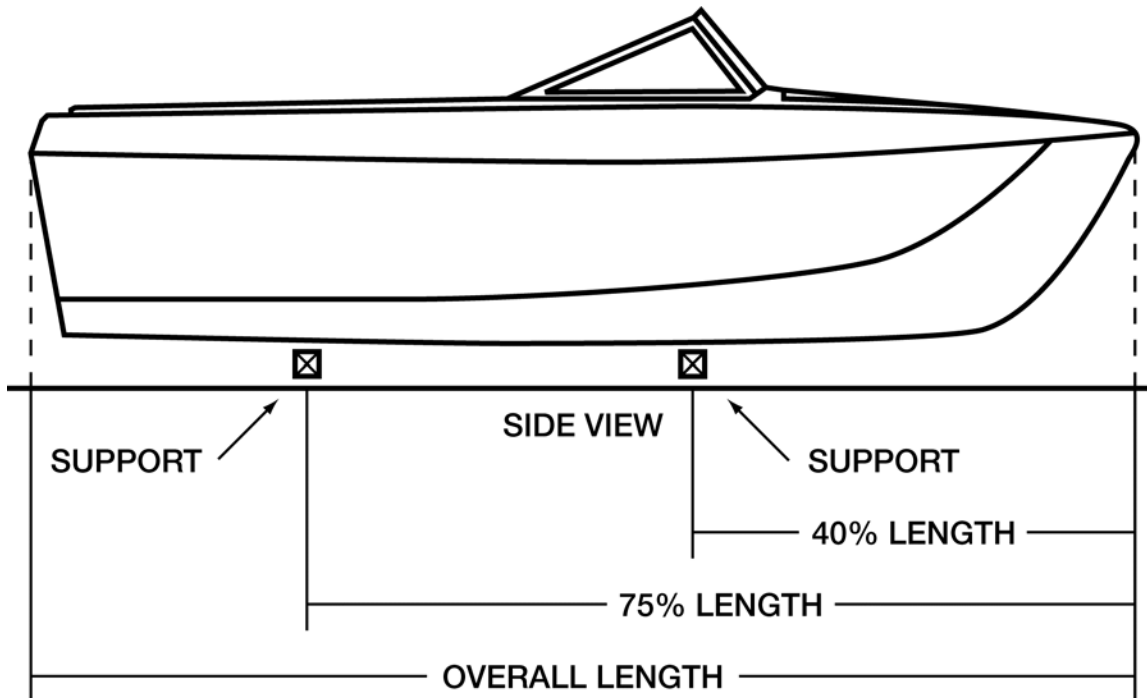

Figure 3—Boat with Deck

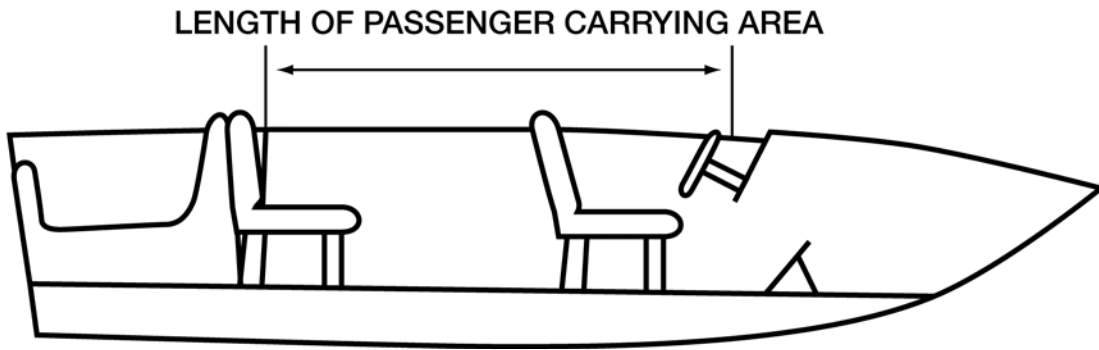

Figure 4—Boat with Center Console

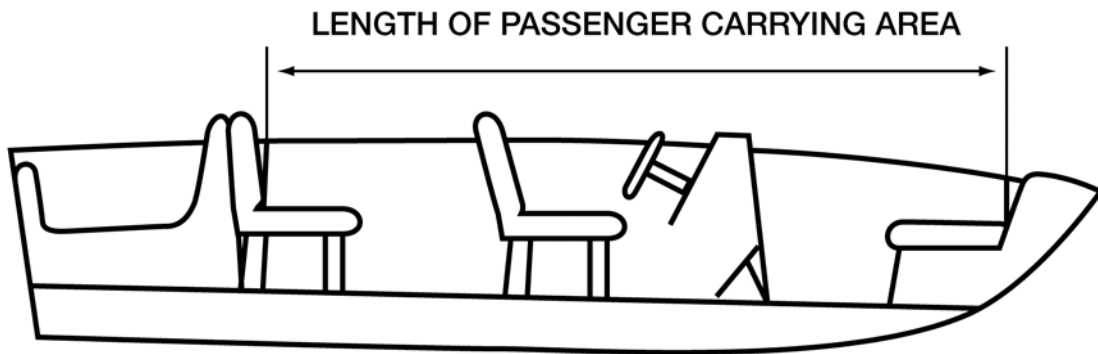

Figure 5—Open Boat with Curved Stem

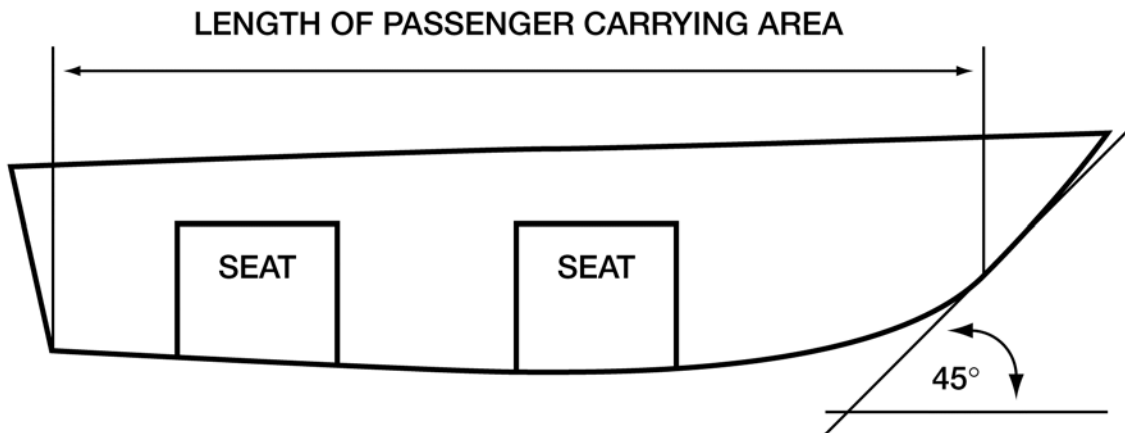

Figure 6—Boat with Cabin

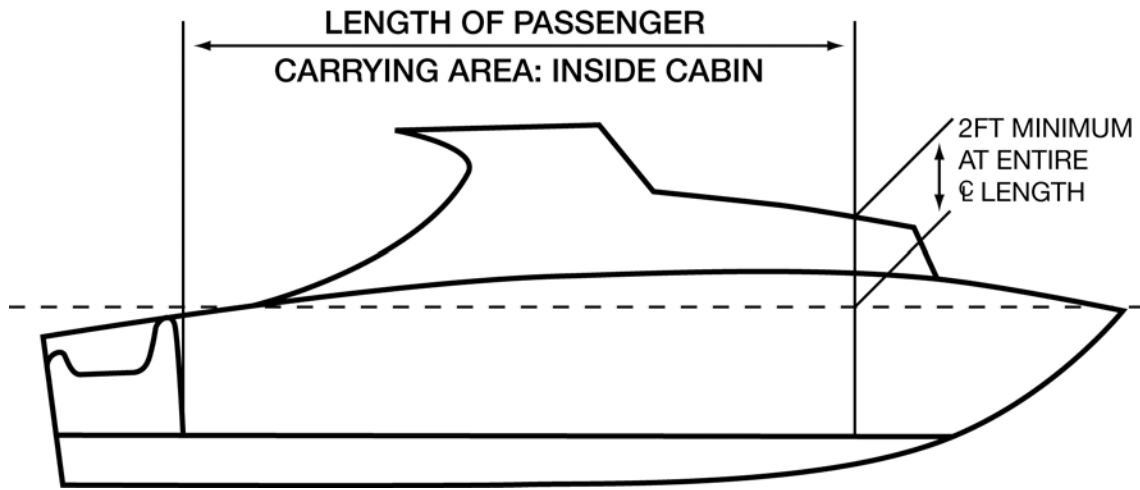

Figure 7—Breadth of Passenger Carrying Area

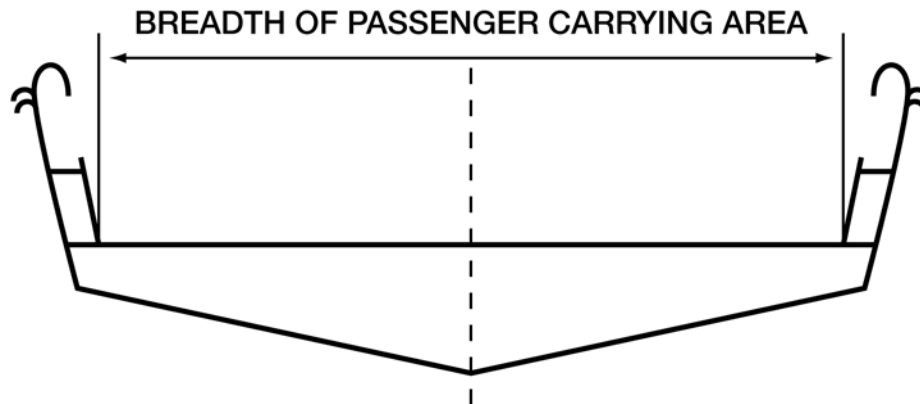

Figure 8—Boat with Round Chine

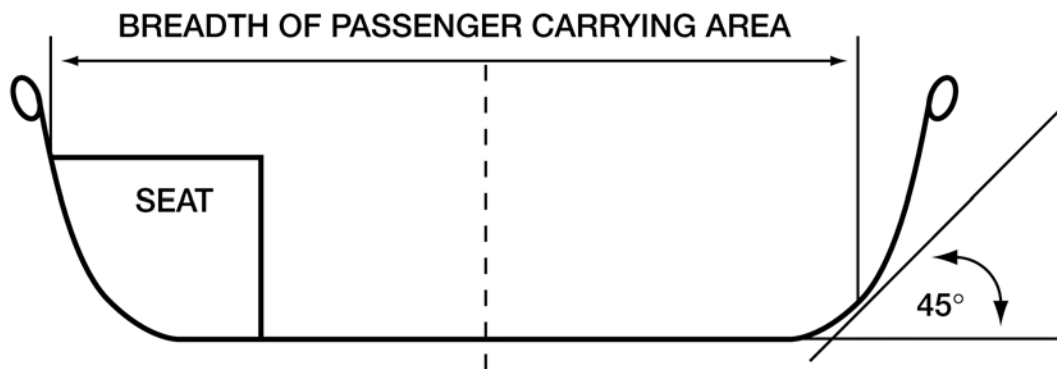



Figure 11—Passenger Carrying Area Location of Center of Gravity of Weights

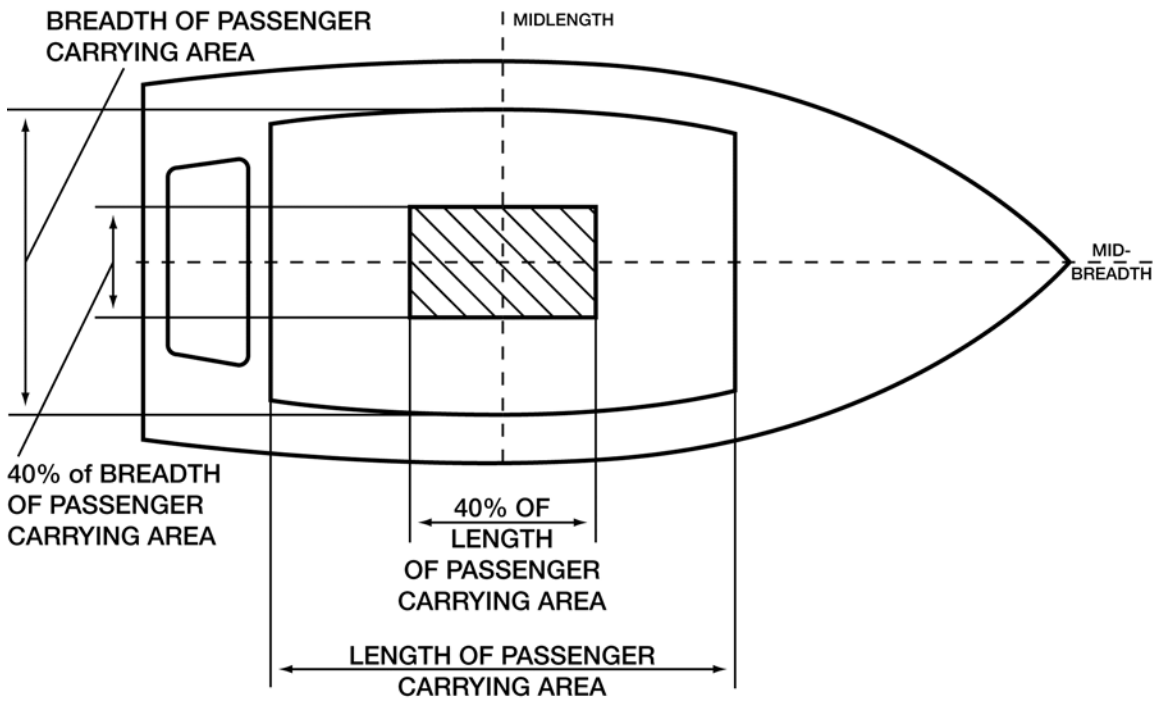
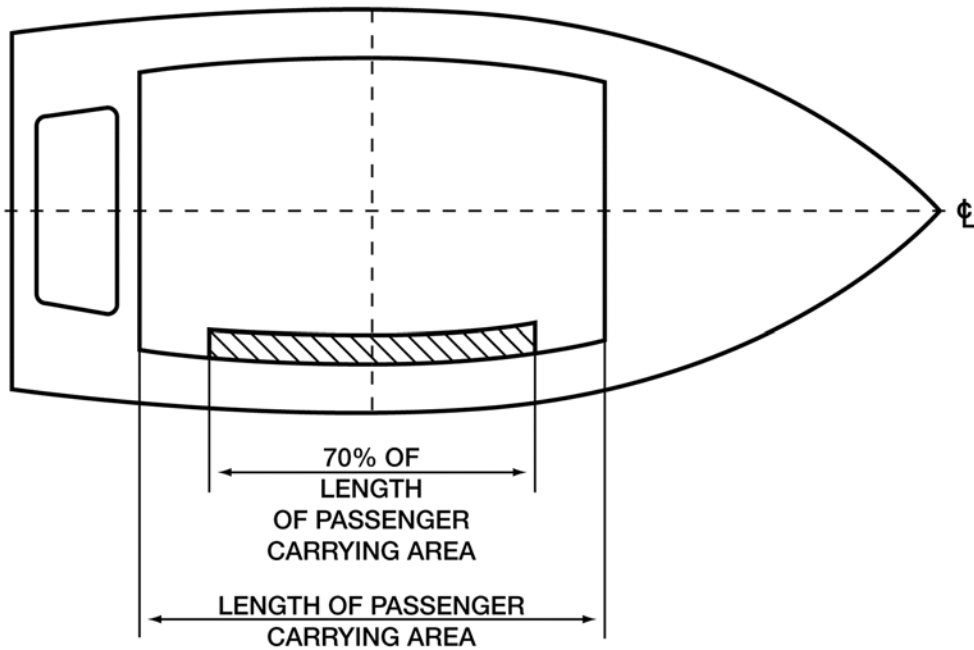
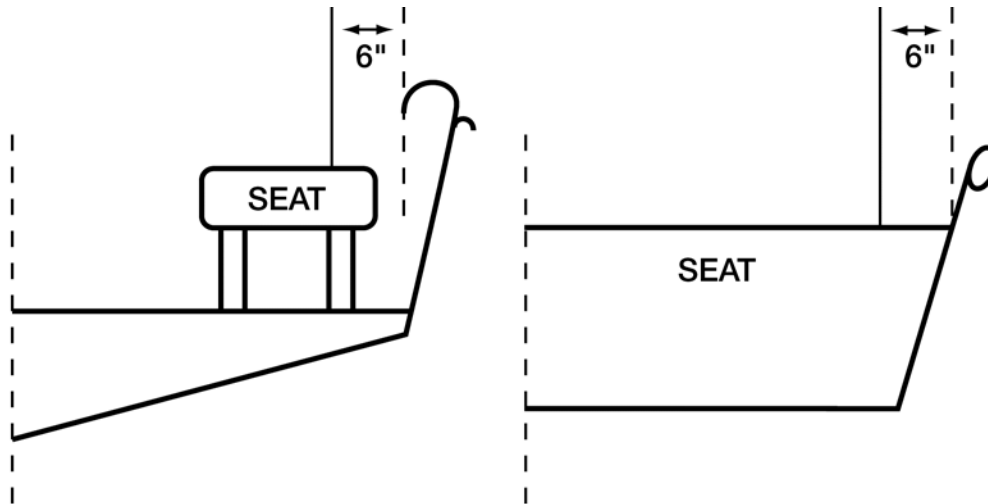

Figure 12—Stability Test Location of Center of Gravity of Weights—Starboard Side



**Figure 13—Locations of Center of Gravity of Weights on Seats**



**Subpart I—Electrical Systems**

Source: CGD 73-217, 42 FR 5944, Jan. 31, 1977, unless otherwise noted.

**GENERAL**

**Sec. 183.401—Purpose, applicability, and effective dates**

(a) This subpart applies to all boats that have gasoline engines, except outboard engines, for electrical generation, mechanical power, or propulsion.

(b) [Reserved]

[CGD 73-217, 42 FR 5944, Jan. 31, 1977, as amended by CGD 81-092, 48 FR 55736, Dec. 15, 1983; USCG-1999-5832, 64 FR 34716, June 29, 1999]

**Sec. 183.402—Definitions**

As used in this subpart—

AWG means American Wire Gauge.

Electrical component means electrical equipment such as, but not limited to, conductors, solenoids, motors, generators, alternators, distributors, resistors, appliances and electrical control devices.

Pigtails means external power conductors or wires that are part of electrical components and appliances, such as bilge pumps, blowers, lamps, switches, solenoids, and fuses.

Sheath means a material used as a continuous protective covering, such as electrical tape, molded rubber, molded plastic, or flexible tubing, around one or more insulated conductors.

[CGD 73-217, 42 FR 5944, Jan. 31, 1977, as amended by CGD 85-098, 52 FR 19728, May 27, 1987; CGD 96-026, 61 FR 33670, June 28, 1996]

**Sec. 183.405—General**

Each electrical component on a boat to which this subpart applies must meet the requirements of this subpart unless the component is part of an outboard engine or part of portable equipment.

**MANUFACTURER REQUIREMENTS****Sec. 183.410—Ignition protection**

- (a) Each electrical component must not ignite a propane gas and air mixture that is 4.25 to 5.25 percent propane gas by volume surrounding the electrical component when it is operated at each of its manufacturer rated voltages and current loadings, unless it is isolated from gasoline fuel sources, such as engines, and valves, connections, or other fittings in vent lines, fill lines, distribution lines or on fuel tanks, in accordance with paragraph (b) of this section.
- (b) An electrical component is isolated from a gasoline fuel source if:
- (1) A bulkhead that meets the requirements of paragraph (c) of this section is between the electrical component and the gasoline fuel source;
  - (2) The electrical component is:
    - (i) Lower than the gasoline fuel source and a means is provided to prevent fuel and fuel vapors that may leak from the gasoline fuel source from becoming exposed to the electrical component; or
    - (ii) Higher than the gasoline fuel source and a deck or other enclosure is between it and the gasoline fuel source; or
  - (3) The space between the electrical component and the gasoline fuel source is at least two feet and the space is open to the atmosphere.
- (c) Each bulkhead required by paragraph (b)(1) of this section must:
- (1) Separate the electrical component from the gasoline fuel source and extend both vertically and horizontally the distance of the open space between the fuel source and the ignition source;
  - (2) Resist a water level that is 12 inches high or one-third of the maximum height of the bulkhead, whichever is less, without seepage of more than one-quarter fluid ounce of fresh water per hour; and
  - (3) Have no opening located higher than 12 inches or one-third the maximum height of the bulkhead, whichever is less, unless the opening is used for the passage of conductors, piping, ventilation ducts, mechanical equipment, and similar items, or doors, hatches, and access panels, and the maximum annular space around each item or door, hatch or access panel must not be more than one-quarter inch.

**Sec. 183.415—Grounding**

If a boat has more than one gasoline engine, grounded cranking motor circuits must be connected to each other by a common conductor circuit that can carry the starting current of each of the grounded cranking motor circuits.

**Sec. 183.420—Batteries**

- (a) Each installed battery must not move more than one inch in any direction when a pulling force of 90 pounds or twice the battery weight, whichever is less, is applied through the center of gravity of the battery as follows:
- (1) Vertically for a duration of one minute.
  - (2) Horizontally and parallel to the boat's center line for a duration of one minute fore and one minute aft.
  - (3) Horizontally and perpendicular to the boat's center line for a duration of one minute to starboard and one minute to port.
- (b) Each battery must be installed so that metallic objects cannot come in contact with the ungrounded battery terminals.

- (c) Each metallic fuel line and fuel system component within 12 inches and above the horizontal plane of the battery top surface as installed must be shielded with dielectric material.
- (d) Each battery must not be directly above or below a fuel tank, fuel filter, or fitting in a fuel line.
- (e) A vent system or other means must be provided to permit the discharge from the boat of hydrogen gas released by the battery.
- (f) [Reserved]
- (g) Each battery terminal connector must not depend on spring tension for its mechanical connection to the terminal.

[CGD 73-217, 42 FR 5944, Jan. 31, 1977, as amended by CGD 81-092, 48 FR 55736, Dec. 15, 1983]

**Sec. 183.425—Conductors: General**

- (a) Each conductor must be insulated, stranded copper.
- (b) Except for intermittent surges each conductor must not carry a current greater than that specified in Table 5 for the conductor's gauge and temperature rating.
- (c) For conductors in engine spaces, amperages must be corrected by the appropriate correction factor in note 1 of Table 5.
- (d) Each conductor in a multiconductor sheath must be at least a No. 18 AWG conductor.
- (e) Each conductor installed separately must be at least a No. 16 AWG conductor.
- (f) Each No. 18 AWG conductor in a multiconductor sheath may not extend out of the sheath more than 30 inches.
- (g) This section does not apply to communications systems; electronic navigation equipment; electronic circuits having a current flow of less than one ampere; conductors which are totally inside an equipment housing; resistance conductors that control circuit amperage; high voltage secondary conductors and terminations that are in ignition systems; pigtails of less than seven inches of exposed length and cranking motor conductors.



**Table 5—Allowable Amperage of Conductors**

Conductor size (AWG)	Temperature rating of conductor insulation						
	60 deg.C (140 deg.F)	75 deg.C (167 deg.F)	80 deg.C (176 deg.F)	90 deg.C (194 deg.F)	105 deg.C (221 deg.F)	125 deg.C (257 deg.F)	200 deg.C (392 deg.F)
18	10	10	15	20	20	25	25
16	15	15	20	25	25	30	35
14	20	20	25	30	35	40	45
12	25	25	35	40	45	50	55
10	40	40	50	55	60	70	70
8	55	65	70	70	80	90	100
6	80	95	100	100	120	125	135
4	105	125	130	135	160	170	180
3	120	145	150	155	180	195	210
2	140	170	175	180	210	225	240
1	165	195	210	210	245	265	280
0	195	230	245	245	285	305	325
00	225	265	285	285	330	355	370
000	260	310	330	330	385	410	430
0000	300	360	385	385	445	475	510

**NOTES**

1. See the following table:	60 deg.C (140 deg.F)	75 deg.C (167 deg.F)	80 deg.C (176 deg.F)	90 deg.C (194 deg.F)	105 deg.C (221 deg.F)	125 deg.C (257 deg.F)	200 deg.C (392 deg.F)
Temperature rating of conductor	0.58	0.75	0.78	0.82	0.85	0.89	1.00
2. See the following table:	<i>Correction factor</i>						
Number of current carrying conductors:							
3	0.70						
4 to 6	0.60						
7 to 24	0.50						
25 and above	0.40						

[CGD 73-217, 42 FR 5944, Jan. 31, 1977; 42 FR 24739, May 16, 1977, as amended by CGD 81-092, 48 FR 55736, Dec. 15, 1983]

**Sec. 183.430—Conductors in circuits of less than 50 volts**

- (a) Each conductor in a circuit that has a nominal voltage of less than 50 volts must:
  - (1) Meet the requirements of Sec. 183.435; or
  - (2) Meet:
    - (i) The insulating material temperature rating requirements of SAE Standard J378; and
    - (ii) SAE Standard J1127, or SAE Standard 1128.
  
- (b) This section does not apply to communication systems; electronic navigation equipment; resistance conductors that control circuit amperage; and pigtails of less than seven inches of exposed length.

[CGD 73-217, 42 FR 5944, Jan. 31, 1977, as amended by CGD 87-009, 53 FR 36971, Sept. 23, 1988]

**Sec. 183.435—Conductors in circuits of 50 volts or more**

- (a) Each conductor in a circuit that has a nominal voltage of 50 volts or more must be:
  - (1) A conductor that has insulation listed and classified moisture resistant and flame retardant in Article 310, NFPA No. 70, National Electric Code;
  - (2) A flexible cord type SO, STO, ST, SJO, SJT, or SJTO listed in Article 400, NFPA No. 70, National Electric Code;
  - (3) A conductor that meets IEEE Standard 45;
  - (4) A conductor that meets UL Standard 1426.

(b) Where the nominal circuit voltage of each of three or more current carrying conductors in a duct, bundle, or cable is 50 volts or more, the amperages of each of those conductors must not exceed the value in table 5 multiplied by the correction factor in note 2 to Table 5 for the number of conductors that carry 50 volts or more.

(c) This section does not apply to communication systems; electronic navigation equipment; resistance conductors that control circuit amperage; conductors in secondary circuits of ignition systems; and pigtailed of less than seven inches of exposed length.

[CGD 73-217, 42 FR 5944, Jan. 31, 1977; 42 FR 24739, May 16, 1977, as amended by CGD 80-047 and CGD 80-046, 45 FR 85450, Dec. 29, 1980; CGD 87-009, 53 FR 36972, Sept. 23, 1988]

**Sec. 183.440—Secondary circuits of ignition systems**

(a) Each conductor in a secondary circuit of an ignition system must meet SAE Standard J557.

(b) The connection of each ignition conductor to a spark plug, coil, or distributor must have a tight fitting cap, boot, or nipple.

[CGD 73-217, 42 FR 5944, Jan. 31, 1977, as amended by USCG-1999-5832, 64 FR 34716, June 29, 1999]

**Sec. 183.445—Conductors: Protection**

(a) Each conductor or group of conductors that passes through a bulkhead, structural member, junction box, or other rigid surface must be protected from abrasion.

(b) Each ungrounded terminal or stud that is continuously energized must meet Sec. 183.455 or must have a boot, nipple, cap, cover, or shield that prevents accidental short-circuiting at the terminals or studs.

[CGD 81-092, 48 FR 55736, Dec. 15, 1983]

**Sec. 183.455—Overcurrent protection: General**

(a) Each ungrounded current-carrying conductor must be protected by a manually reset, tripfree circuit breaker or fuse.

(b) A manually reset, trip-free circuit breaker or fuse must be placed at the source of power for each circuit or conductor except:

- (1) If it is physically impractical to place the circuit breaker or fuse at the source of power, it may be placed within seven inches of the source of power for each circuit or conductor measured along the conductor.
- (2) If it is physically impractical to place the circuit breaker or fuse at or within seven inches of the source of power, it may be placed within 40 inches of the source of power for each circuit or conductor, measured along the conductor, if the conductor is contained throughout its entire distance between the source of power and the required circuit breaker or fuse in a sheath or enclosure such as a junction box, control box, or enclosed panel.

- (c) The current rating of each circuit breaker or fuse must not exceed:
  - (1) For circuits of less than 50 volts, 150% of the value of the amperage in Table 5 for the conductor size it is protecting; and
  - (2) For circuits of 50 volts or more, the value of the amperage in Table 5 for the conductor size it is protecting. If this value does not correspond to a standard size or rated circuit breaker or fuse the next larger size or rated circuit breaker or fuse may be used if it does not exceed 150% of the allowed current capacity of the conductor.
- (d) The voltage rating of each circuit breaker or fuse must not be less than the nominal circuit voltage of the circuit it is protecting.
- (e) This section does not apply to resistance conductors that control circuit amperage; conductors in secondary circuits of ignition systems; pigtailed of less than seven inches of exposed length; and power supply conductors in cranking motor circuits.

[CGD 73-217, 42 FR 5944, Jan. 31, 1977, as amended by CGD 78-090, 44 FR 68466, Nov. 29, 1979]

**Sec. 183.460—Overcurrent protection: Special applications**

- (a) Each ungrounded output conductor from a storage battery must have a manually reset, trip-free circuit breaker or fuse, unless the output conductor is in the main power feed circuit from the battery to an engine cranking motor. The circuit breaker or fuse must be within 72 inches of the battery measured along the conductor, unless, for boats built prior to August 1, 1985, the circuit has a switch that disconnects the battery.
- (b) Each ungrounded output conductor from an alternator or generator, except for self-limiting alternators or generators, must have a circuit breaker or fuse that has a current rating that does not exceed 120 percent of the maximum rated current of the alternator or generator at 60 deg. C.

[CGD 73-217, 42 FR 5944, Jan. 31, 1977, as amended by CGD 81-092, 48 FR 55736, Dec. 15, 1983]

**Subpart J—Fuel Systems**

*Source: CGD 74-209, 42 FR 5950, Jan. 31, 1977, unless otherwise noted.*

**GENERAL**

**Sec. 183.501—Applicability**

- (a) This subpart applies to all boats that have gasoline engines, except outboard engines, for electrical generation, mechanical power, or propulsion.
- (b) [Reserved]

[CGD 74-209, 42 FR 5950, Jan. 31, 1977, as amended by CGD 81-092, 48 FR 55736, Dec. 15, 1983; USCG-1999-5832, 64 FR 34716, June 29, 1999]

**Sec. 183.505—Definitions**

As used in this subpart:

Flame arrestor means a device or assembly that prevents passage of flame through a fuel vent.

Fuel system means the entire assembly of the fuel fill, vent, tank, and distribution components, including pumps, valves, strainers, carburetors, and filters.

Static floating position means the attitude in which a boat floats in calm water, with each fuel tank filled to its rated capacity, but with no person or item of portable equipment on board.

[CGD 74-209, 42 FR 5950, Jan. 31, 1977, as amended by CGD 85-098, 52 FR 19728, May 27, 1987]

**Sec. 183.507—General**

Each fuel system component on a boat to which this subpart applies must meet the requirements of this subpart unless the component is part of an outboard engine or is part of portable equipment.

**EQUIPMENT STANDARDS**

**Sec. 183.510—Fuel tanks**

- (a) Each fuel tank in a boat must have been tested by its manufacturer under Sec. 183.580 and not leak when subjected to the pressure marked on the tank label under Sec. 183.514(b)(5).
- (b) Each fuel tank must not leak if subjected to the fire test under Sec. 183.590. Leakage is determined by the static pressure test under Sec. 183.580, except that the test pressure must be at least one-fourth PSIG.
- (c) Each fuel tank of less than 25 gallons capacity must not leak if tested under Sec. 183.584.
- (d) Each fuel tank with a capacity of 25 to 199 gallons must not leak if tested under Sec. 183.586.
- (e) Each fuel tank of 200 gallons capacity or more must not leak if tested under Secs. 183.586 and 183.588.

[CGD 74-209, 42 FR 5950, Jan. 31, 1977, as amended by CGD 81-092, 48 FR 55736, Dec. 15, 1983]

**Sec. 183.512—Fuel tanks: Prohibited materials**

- (a) A fuel tank must not be constructed from terneplate.
- (b) Unless it has an inorganic sacrificial galvanic coating on the inside and outside of the tank, a fuel tank must not be constructed from black iron or carbon steel.
- (c) A fuel tank encased in cellular plastic or in fiber reinforced plastic must not be constructed from a ferrous alloy.

[CGD 74-209, 42 FR 5950, Jan. 31, 1977; 42 FR 24739, May 16, 1977]

**Sec. 183.514—Fuel tanks: Labels**

- (a) Each fuel tank must have a label that meets the requirements of paragraphs (b) through (d) of this section.
- (b) Each label required by paragraph (a) of this section must contain the following information:
  - (1) Fuel tank manufacturer's name (or logo) and address.
  - (2) Month (or lot number) and year of manufacture.
  - (3) Capacity in U.S. gallons.
  - (4) Material of construction.
  - (5) The pressure the tank is designed to withstand without leaking.
  - (6) Model number, if applicable.
  - (7) The statement, "This tank has been tested under 33 CFR 183.510(a)."
  - (8) If the tank is tested under Sec. 183.584 at less than 25g vertical accelerations the statement, "Must be installed aft of the boat's half length."

- (c) Each letter and each number on a label must:
  - (1) Be at least 1/16 inch high and
  - (2) Contrast with the basic color of the label or be embossed on the label.
- (d) Each label must:
  - (1) Withstand the combined effects of exposure to water, oil, salt spray, direct sunlight, heat, cold, and wear expected in normal operation of the boat, without loss of legibility; and
  - (2) Resist efforts to remove or alter the information on the label without leaving some obvious sign of such efforts.

[CGD 74-209, 42 FR 5950, Jan. 31, 1977, as amended by CGD 81-092, 48 FR 55737, Dec. 15, 1983; USCG-1999-5832, 64 FR 34716, June 29, 1999]

**Sec. 183.516—Cellular plastic used to encase fuel tanks**

- (a) Cellular plastic used to encase metallic fuel tanks must:
  - (1) Not change volume by more than five percent or dissolve after being immersed in any of the following liquids for 24 hours at 29 deg. C:
    - (i) Reference fuel B ASTM D 471 (incorporated by reference, see Sec. 183.5).
    - (ii) No. 2 reference oil of ASTM D 471 (incorporated by reference, see Sec. 183.5).
    - (iii) Five percent solution of trisodium phosphate in water; and
  - (2) Not absorb more than 0.12 pound of water per square foot of cut surface, measure under Military Specification MIL P-21929B.
- (b) Non-polyurethane cellular plastic used to encase metallic fuel tanks must have a compressive strength of at least 60 pounds per square inch at ten percent deflection measured under ASTM D 1621 (incorporated by reference, see Sec. 183.5), “Compressive Strength of Rigid Cellular Plastics”.
- (c) Polyurethane cellular plastic used to encase metallic fuel tanks must have a density of at least 2.0 pounds per cubic foot, measured under ASTM D 1622 (incorporated by reference, see Sec. 183.5), “Apparent Density of Rigid Cellular Plastics.”

[CGD 74-209, 42 FR 5950, Jan. 31, 1977, as amended by CGD 77-98, 42 FR 36253, July 14, 1977; CGD 81-092, 48 FR 55737, Dec. 15, 1983; USCG-2000-7223, 65 FR 40059, June 29, 2000]

**Sec. 183.518—Fuel tank openings**

Each opening into the fuel tank must be at or above the topmost surface of the tank.

**Sec. 183.520—Fuel tank vent systems**

- (a) Each fuel tank must have a vent system that prevents pressure in the tank from exceeding 80 percent of the pressure marked on the tank label under Sec. 183.514(b)(5).
- (b) Each vent must:
  - (1) Have a flame arrester that can be cleaned unless the vent is itself a flame arrester; and
  - (2) Not allow a fuel overflow at the rate of up to two gallons per minute to enter the boat.

[CGD 74-209, 42 FR 5950, Jan. 31, 1977, as amended by CGD 77-98, 42 FR 36253, July 14, 1977]

**Sec. 183.524—Fuel pumps**

- (a) Each diaphragm pump must not leak fuel from the pump if the primary diaphragm fails.
- (b) Each electrically operated fuel pump must not operate except when the engine is operating or when the engine is started.
- (c) If tested under Sec. 183.590, each fuel pump, as installed in the boat, must not leak more than five ounces of fuel in 2-1/2 minutes, inclusive of leaks from fuel line, fuel filter and strainer.

[CGD 74-209, 42 FR 5950, Jan. 31, 1977, as amended by CGD 77-98, 42 FR 36253, July 14, 1977]

**Sec. 183.526—Carburetors**

- (a) [Reserved]
- (b) Each carburetor must not leak more than five cubic centimeters of fuel in 30 seconds when:
  - (1) The float valve is open;
  - (2) The carburetor is at half throttle; and
  - (3) The engine is cranked without starting; or
  - (4) The fuel pump is delivering the maximum pressure specified by its manufacturer.
- (c) Each updraft and horizontal draft carburetor must have a device that:
  - (1) Collects and holds fuel that flows out of the carburetor venturi section toward the air intake;
  - (2) Prevents collected fuel from being carried out of the carburetor assembly by the shock wave of a backfire or by reverse air flow; and
  - (3) Returns collected fuel to the engine induction system after the engine starts,

[CGD 74-209, 42 FR 5950, Jan. 31, 1977, as amended by CGD 77-98, 42 FR 36253, July 14, 1977]

**Sec. 183.528—Fuel stop valves**

- (a) Each electrically operated fuel stop valve in a fuel line between the fuel tank and the engine must:
  - (1) Open electrically only when the ignition switch is on; and
  - (2) Operate manually.
- (b) If tested in accordance with the fire test under Sec. 183.590, a fuel stop valve installed in a fuel line system requiring metallic fuel lines or “USCG Type A1” hose must not leak fuel.

[CGD 74-209, 42 FR 5950, Jan. 31, 1977, as amended by CGD 85-098, 52 FR 19728, May 27, 1987]

**Sec. 183.530—Spud, pipe, and hose fitting configuration**

Except when used for a tank fill line, each spud, pipe, or hose fitting used with hose clamps must have:

- (a) A bead;
- (b) A flare; or
- (c) A series of annular grooves or serrations no less than 0.015 inches deep, except a continuous helical thread, knurl, or groove.

[CGD 74-209, 42 FR 5950, Jan. 31, 1977, as amended by USCG-1999-5832, 64 FR 34716, June 29, 1999]

**Sec. 183.532—Clips, straps, and hose clamps**

- (a) Each clip, strap, and hose clamp must:
  - (1) Be made from a corrosion resistant material; and
  - (2) Not cut or abrade the fuel line.
  
- (b) If tested in accordance with the fire test under Sec. 183.590, a hose clamp installed on a fuel line system requiring metallic fuel lines or “USCG Type A1” hose must not separate under a one pound tensile force.

[CGD 74-209, 42 FR 5950, Jan. 31, 1977, as amended by CGD 85-098, 52 FR 19728, May 27, 1987]

**Sec. 183.534—Fuel filters and strainers**

If tested under Sec. 183.590, each fuel filter and strainer, as installed in the boat, must not leak more than five ounces of fuel in 2-1/2 minutes inclusive of leaks from the fuel pump and fuel line.

[CGD 77-98, 42 FR 36253, July 14, 1977]

**Sec. 183.536—Seals and gaskets in fuel filters and strainers**

- (a) [Reserved]
  
- (b) Each gasket and each sealed joint in a fuel filter and strainer must not leak when subjected for 24 hours to a gasoline that has at least a 50 percent aromatic content at the test pressure marked on the fuel tank label.

[CGD 81-092, 48 FR 55737, Dec. 15, 1983]

**Sec. 183.538—Metallic fuel line materials**

Each metallic fuel line connecting the fuel tank with the fuel inlet connection on the engine must:

- (a) Be made of seamless annealed copper, nickel copper, or copper-nickel; and
  
- (b) Except for corrugated flexible fuel line, have a minimum wall thickness of 0.029 inches.

**Sec. 183.540—Hoses: Standards and markings**

- (a) “USCG Type A1” hose means hose that meets the performance requirements of:
  - (1) SAE Standard J1527DEC85, Class 1 and the fire test in Sec. 183.590; or
  - (2) Underwriters’ Laboratories, Inc. (UL) Standard 1114.
  
- (b) “USCG Type A2” hose means hose that meets the performance requirements of SAE Standard J1527DEC85, Class 2 and the fire test in Sec. 183.590.
  
- (c) “USCG Type B1” hose means hose that meets the performance requirements of SAE Standard J1527DEC85, Class 1.
  
- (d) “USCG Type B2” hose means hose that meets the performance requirements of SAE Standard J1527DEC85, Class 2.

*Note: SAE Class 1 hose has a permeation rating of 100 grams or less fuel loss per square meter of interior surface in 24 hours.*

SAE Class 2 hose has a permeation rating of 300 grams or less fuel loss per square meter of interior surface in 24 hours.

- (e) Each "USCG Type A1," "USCG Type A2," "USCG Type B1," and "USCG Type B2" hose must be identified by the manufacturer by a marking on the hose.
- (f) Each marking must contain the following information in English:
  - (1) The statement "USCG TYPE (insert A1 or A2 or B1 or B2)."
  - (2) The year in which the hose was manufactured.
  - (3) The manufacturer's name or registered trademark.
- (g) Each character must be block capital letters and numerals that are at least one eighth-inch high.
- (h) Each marking must be permanent, legible, and on the outside of the hose at intervals of 12 inches or less.

[CGD 85-098, 52 FR 19728, May 27, 1987]

**Sec. 183.542—Fuel systems**

- (a) Each fuel system in a boat must have been tested by the boat manufacturer and not leak when subjected to the greater of the following pressures:
  - (1) Three pounds per square inch; or
  - (2) One and one-half times the pressure created in the lowest part of the fuel system when it is filled to the level of overflow with fuel.
- (b) The test pressure shall be obtained with air or inert gas.

[CGD 81-092, 48 FR 55737, Dec. 15, 1983]

**MANUFACTURER REQUIREMENTS**

**Sec. 183.550—Fuel tanks: Installation**

- (a) Each fuel tank must not be integral with any boat structure or mounted on an engine.
- (b) Each fuel tank must not move at the mounting surface more than one-fourth inch in any direction.
- (c) Each fuel tank must not support a deck, bulkhead, or other structural component.
- (d) Water must drain from the top surface of each metallic fuel tank when the boat is in its static floating position.
- (e) Each fuel tank support, chock, or strap that is not integral with a metallic fuel tank must be insulated from the tank surface by a nonmoisture absorbing material.
- (f) Cellular plastic must not be the sole support for a metallic fuel tank.
- (g) If cellular plastic is the sole support of a non-metallic fuel tank, the cellular plastic must meet the requirements of Sec. 183.516 (b) or (c).
- (h) Each fuel tank labeled under Sec. 183.514(b)(8) for installation aft of the boat's half length must be installed with its center of gravity aft of the boat's half length.

[CGD 74-209, 42 FR 5950, Jan. 31, 1977, as amended by CGD 81-092, 48 FR 55737, Dec. 15, 1983; USCG-1999-5832, 64 FR 34716, June 29, 1999]



**Sec. 183.552—Plastic encased fuel tanks: Installation**

- (a) Each fuel tank encased in cellular plastic foam or in fiber reinforced plastic must have the connections, fittings, and labels accessible for inspection and maintenance.
- (b) If a metallic fuel tank is encased in cellular plastic or in fiber reinforced plastic, water must not collect between the plastic and the surface of the tank or be held against the tank by capillary action.
- (c) If the plastic is bonded to the surface of a metallic fuel tank, the adhesive strength of the metal to the plastic bond must exceed the cohesive strength of the plastic.

**Sec. 183.554—Fittings, joints, and connections**

Each fuel system fitting, joint, and connection must be arranged so that it can be reached for inspection, removal, or maintenance without removal of permanent boat structure.

**Sec. 183.556—Plugs and fittings**

- (a) A fuel system must not have a fitting for draining fuel.
- (b) A plug used to service the fuel filter or strainer must have a tapered pipethread or be a screw type fitted with a locking device other than a split lock washer.

**Sec. 183.558—Hoses and connections**

- (a) Each hose used between the fuel pump and the carburetor must be “USCG Type A1” hose.
- (b) Each hose used—
  - (1) For a vent line or fill line must be:
    - (i) “USCG Type A1” or “USCG Type A2”; or
    - (ii) “USCG Type B1” or “USCG Type B2” if no more than five ounces of fuel is discharged in 2-1/2 minutes when:
      - (A) The hose is severed at the point where maximum drainage of fuel would occur,
      - (B) The boat is in its static floating position, and
      - (C) The fuel system is filled to the capacity marked on the tank label under Sec. 183.514(b)(3).
  - (2) From the fuel tank to the fuel inlet connection on the engine must be:
    - (i) “USCG Type A1”; or
    - (ii) “USCG Type B1” if no more than five ounces of fuel is discharged in 2-1/2 minutes when:
      - (A) The hose is severed at the point where maximum drainage of fuel would occur,
      - (B) The boat is in its static floating position, and
      - (C) The fuel system is filled to the capacity marked on the tank label under Sec. 183.514(b)(3).
- (c) Each hose must be secured by:
  - (1) A swaged sleeve;
  - (2) A sleeve and threaded insert; or
  - (3) A hose clamp.
- (d) The inside diameter of a hose must not exceed the actual minor outside diameter of the connecting spud, pipe, or fitting by more than the distance shown in Table 8.

**Table 8**

If minor outside diameter of the connecting spud, pipe, or fitting is—	The inside diameter of the hose must not exceed the minor outside diameter of the connecting spud, pipe, or hose fitting by more than the following distance:
Less than 3/8 in.	0.020 in.
3/8 in. to 1 in.	0.035 in.
Greater than 1 in.	0.065 in.

[CGD 74-209, 42 FR 5950, Jan. 31, 1977, as amended by CGD 85-098, 52 FR 19728, May 27, 1987]

**Sec. 183.560—Hose clamps: Installation**

Each hose clamp on a hose from the fuel tank to the fuel inlet connection on the engine, a hose between the fuel pump and the carburetor, or a vent line must:

- (a) Be used with hose designed for clamps;
- (b) [Reserved]
- (c) Be beyond the bead, flare, or over the serrations of the mating spud, pipe, or hose fitting; and
- (d) Not depend solely on the spring tension of the clamp for compressive force.

[CGD 74-209, 42 FR 5950, Jan. 31, 1977, as amended by CGD 81-092, 48 FR 55737, Dec. 15, 1983]

**Sec. 183.562—Metallic fuel lines**

- (a) Each metallic fuel line that is mounted to the boat structure must be connected to the engine by a flexible fuel line.
- (b) Each metallic fuel line must be attached to the boat's structure within four inches of its connection to a flexible fuel line.

**Sec. 183.564—Fuel tank fill system**

- (a) Each fuel fill opening must be located so that a gasoline overflow of up to five gallons per minute for at least five seconds will not enter the boat when the boat is in its static floating position.
- (b) Each hose in the tank fill system must be secured to a pipe, spud, or hose fitting by:
  - (1) A swaged sleeve;
  - (2) A sleeve and threaded insert; or
  - (3) Two adjacent metallic hose clamps that do not depend solely on the spring tension of the clamps for compressive force.
- (c) Each hose clamp in the tank fill system must be used with a hose designed for clamps.
- (d) Hose clamps used in the tank fill system must:
  - (1) Have a minimum nominal band width of at least one-half inch; and
  - (2) Be over the hose and the spud, pipe, or hose fitting.

[CGD 74-209, 42 FR 5950, Jan. 31, 1977, as amended by CGD 81-092, 48 FR 55737, Dec. 15, 1983]

**Sec. 183.566—Fuel pumps: Placement**

Each fuel pump must be on the engine it serves or within 12 inches of the engine, unless it is a fuel pump used to transfer fuel between tanks.

**Sec. 183.568—Anti-siphon protection**

Each fuel line from the fuel tank to the fuel inlet connection on the carburetor must:

- (a) Be above the level of the tank top; or
- (b) Have an anti-siphon device or an electrically operated fuel stop valve:
  - (1) At the tank withdrawal fitting; or
  - (2) Installed so the line from the fuel tank is above the top of the tank; or
- (c) Provided that the fuel tank top is below the level of the carburetor inlet, be metallic fuel lines meeting the construction requirements of Sec. 183.538 or "USCG Type A1" hose, with one or two manual shutoff valves installed as follows:
  - (1) Directly at the fuel tank connection arranged to be readily accessible for operation from outside of the compartment, and
  - (2) If the length of fuel line from the tank outlet to the engine inlet is greater than 12 feet, a manual shutoff valve shall be installed at the fuel inlet connection to the engine.

[CGD 74-209, 42 FR 5950, Jan. 31, 1977, as amended by CGD 81-092, 48 FR 55737, Dec. 15, 1983; CGD 85-098, 52 FR 19729, May 27, 1987]

**Sec. 183.570—Fuel filters and strainers: Installation**

Each fuel filter and strainer must be supported on the engine or boat structure independent from its fuel line connections, unless the fuel filter or strainer is inside a fuel tank.

**Sec. 183.572—Grounding**

Each metallic component of the fuel fill system and fuel tank which is in contact with fuel must be statically grounded so that the resistance between the ground and each metallic component of the fuel fill system and fuel tank is less than 100 ohms.

**TESTS****Sec. 183.580—Static pressure test for fuel tanks**

A fuel tank is tested by performing the following procedures in the following order:

- (a) Fill the tank with air or inert gas to the pressure marked on the tank label under Sec. 183.514(b)(5).
- (b) Examine each tank fitting and seam for leaks using a leak detection method other than the pressure drop method.

[CGD 74-209, 42 FR 5950, Jan. 31, 1977, as amended by CGD 81-092, 48 FR 55737, Dec. 15, 1983]

**Sec. 183.584—Shock test**

A fuel tank is tested by performing the following procedures in the following order:

- (a) Perform the static pressure test under Sec. 183.580.
- (b) If the tank is non-metallic, fill it to capacity with a gasoline that has at least a 50 percent aromatic content. Keep the fuel in the tank at 21 deg. C or higher for 30 days prior to testing.

- (c) Mount the tank to the platform of an impact test machine.
- (d) Fill the tank to capacity with water.
- (e) Apply one of the following accelerations within three inches of the center of the horizontal mounting surface of the tank. The duration of each vertical acceleration pulse is measured at the base of the shock envelope.
  - (1) If the tank is not labeled under Sec. 183.514(b)(8) for installation aft of the half length of the boat, apply 1000 cycles of 25g vertical accelerations at a rate of 80 cycles or less per minute. The duration of the acceleration pulse must be between 6 and 14 milliseconds.
  - (2) If the tank is manufactured for installation with its center of gravity aft of the half length of the boat, apply 1000 cycles of 15g vertical accelerations at a rate of 80 cycles or less per minute. The duration of the shock pulse must be between 6 and 14 milliseconds.
- (f) Perform the static pressure test under Sec. 183.580.

[CGD 74-209, 42 FR 5950, Jan. 31, 1977, as amended by USCG-1999-5832, 64 FR 34716, June 29, 1999]

**Sec. 183.586—Pressure impulse test**

A fuel tank is tested by performing the following procedures in the following order:

- (a) Perform the static pressure test under Sec. 183.580.
- (b) If the tank is non-metallic, fill it to capacity with a gasoline that has at least a 50 percent aromatic content. Keep the fuel in the tank at 21 deg. C or higher for 30 days prior to testing.
- (c) Mount the tank on a test platform.
- (d) Fill the tank to capacity with water.
- (e) Cap and seal each opening in the tank.
- (f) Apply 25,000 cycles of pressure impulse at the rate of no more than 15 impulses per minute varying from zero to three PSIG to zero inside the tank top from a regulated source of air, inert gas, or water.
- (g) Perform the static pressure test under Sec. 183.580.

**Sec. 183.588—Slosh test**

A fuel tank is tested by performing the following procedures in the following order:

- (a) Perform the static pressure test under Sec. 183.580.
- (b) Perform the pressure impulse test under Sec. 183.586.
- (c) Secure the tank to the platform of a tank rocker assembly.
- (d) Fill the tank to one-half capacity with water.
- (e) Cap and seal each opening in the tank.
- (f) Apply 500,000 cycles or rocking motion 15 degrees to each side of the tank centerline at the rate of 15 to 20 cycles a minute. The axis of rotation of the rocker and fuel tank must be perpendicular to the centerline of the tank length at a level six inches or less above or below the tank's bottom.

- (g) Perform the static pressure test under Sec. 183.580.

[CGD 74-209, 42 FR 5950, Jan. 31, 1977, as amended by USCG-1999-5832, 64 FR 34716, June 29, 1999]

**Sec. 183.590—Fire test**

- (a) A piece of equipment is tested under the following conditions and procedures:
- (1) Fuel stop valves, “USCG Type A1” or USCG Type A2” hoses and hose clamps are tested in a fire chamber.
  - (2) Fuel filters, strainers, and pumps are tested in a fire chamber or as installed on the engine in the boat.
  - (3) Fuel tanks must be tested filled with fuel to one-fourth the capacity marked on the tank in a fire chamber or in an actual or simulated hull section.
- (b) Each fire test is conducted with free burning heptane and the component must be subjected to a flame for 2-1/2 minutes.
- (c) If the component is tested in a fire chamber:
- (1) The temperature within one inch of the component must be at least 648 deg.C sometime during the 2-1/2 minute test;
  - (2) The surface of the heptane must be 8 to 10 inches below the component being tested; and
  - (3) The heptane must be in a container that is large enough to permit the perimeter of the top surface of the heptane to extend beyond the vertical projection of the perimeter of the component being tested.
- (d) If the component is being tested as installed on an engine, heptane sufficient to burn 2-1/2 minutes must be poured over the component and allowed to run into a flat bottomed pan under the engine. The pan must be large enough to permit the perimeter of the top surface of the heptane to extend beyond the vertical projection of the perimeter of the engine.
- (e) If a fuel tank is being tested in an actual or simulated hull section, the actual or simulated hull section must be of sufficient size to contain enough heptane to burn for 2-1/2 minutes in a place adjacent to the tank.

[CGD 74-209, 42 FR 5950, Jan. 31, 1977, as amended by CGD 77-98, 42 FR 36253, July 14, 1977; CGD 85-098, 52 FR 19729, May 27, 1987]

**Subpart K—Ventilation**

*Source: CGD 76-082, 44 FR 73027, Dec. 17, 1979, unless otherwise noted.*

**Sec. 183.601—Applicability**

This subpart applies to all boats that have gasoline engines for electrical generation, mechanical power, or propulsion.

[USCG-1999-5832, 64 FR 34716, June 29, 1999]

**Sec. 183.605—Definitions**

As used in this subpart:

Fuel means gasoline.

Open to the atmosphere means a compartment that has at least 15 square inches of open area directly exposed to the atmosphere for each cubic foot of net compartment volume.

[CGD 76-082, 44 FR 73027, Dec. 17, 1979, as amended by CGD 85-098, 52 FR 19729, May 27, 1987]

**Sec. 183.607—Incorporation by reference**

(a) The following standards are incorporated by reference. Copies may be obtained from the sources indicated. They are also available for inspection at Coast Guard Headquarters, 2100 Second Street, SW., Washington, DC 20593-0001 and at the Office of the Federal Register Library, 800 North Capitol Street, NW., suite 700, Washington, DC 20408.

- (1) AMCA Standard 210-74, Figure 12. Air Moving and Conditioning Association, 30 West University Drive, Arlington Heights, Illinois 60004.
- (2) ASTM Standard D 471. American Society for Testing and Materials, 100 Barr Harbor Drive, West Conshohocken, PA 19428-2959.
- (3) UL Standard 1128, Underwriters Laboratories, Incorporated, 12 Laboratory Drive, Research Triangle Park, NC 27709-3995.

(b) The Director of the Federal Register approved the incorporation by reference in paragraph (a)(2) on September 26, 1976 and the incorporations in paragraphs (a)(1) and (3) on March 24, 1978.

[CGD 76-082, 44 FR 73027, Dec. 17, 1979, as amended by CGD 82-010, 48 FR 8273, Feb. 28, 1983; USCG-2000-7223, 65 FR 40059, June 29, 2000]

**Sec. 183.610—Powered ventilation system**

(a) Each compartment in a boat that has a permanently installed gasoline engine with a cranking motor must:

- (1) Be open to the atmosphere, or
- (2) Be ventilated by an exhaust blower system.

(b) Each exhaust blower or combination of blowers must be rated at an air flow capacity not less than that computed by the formulas given in Table 183.610, Column 2. Blower rating must be determined according to AMCA Standard 210-74, Figure 12, or UL Standard 1128.

**Table 183.610**

Col. 1 <sup>1</sup>	Col. 2 <sup>2</sup>	Col. 3 <sup>3</sup>
<b>Below 34</b>	Fr=50	Fo=20
<b>34 to 100</b>	Fr=1.5V	Fo=0.6V
<b>Over 100</b>	Fr=V/2+100	Fo=0.2V+40

<sup>1</sup> Net compartment volume of engine compartment and compartments open thereto (V) cubic feet.

<sup>2</sup> Rated blower capacity (Fr) cubic feet per minute.

<sup>3</sup> Blower system output (Fo) cubic feet per minute.

(c) Each exhaust blower system required by paragraph (a)(2) of this section must exhaust air from the boat at a rate which meets the requirements of Table 183.610, Column 3 when the engine is not operating.

(d) Each intake duct for an exhaust blower must be in the lower one-third of the compartment and above the normal level of accumulated bilge water.

- (e) More than one exhaust blower may be used in combination to meet the requirements of this section.
- (f) Each boat that is required to have an exhaust blower must have a label that:
- (1) Is located as close as practicable to each ignition switch;
  - (2) Is in plain view of the operator; and
  - (3) Has at least the following information:

WARNING—GASOLINE VAPORS CAN EXPLODE. BEFORE STARTING ENGINE OPERATE BLOWER FOR 4 MINUTES AND CHECK ENGINE COMPARTMENT BILGE FOR GASOLINE VAPORS.

#### **Sec. 183.620—Natural ventilation system**

- (a) Except for compartments open to the atmosphere, a natural ventilation system that meets the requirements of Sec. 183.630 must be provided for each compartment in a boat that:
- (1) Contains a permanently installed gasoline engine;
  - (2) Has openings between it and a compartment that requires ventilation, where the aggregate area of those openings exceeds 2 percent of the area between the compartments, except as provided in paragraph (c) of this section;
  - (3) Contains a permanently installed fuel tank and an electrical component that is not ignition protected in accordance with Sec. 183.410(a);
  - (4) Contains a fuel tank that vents into that compartment; or
  - (5) Contains a non-metallic fuel tank:
    - (i) With an aggregate permeability rate exceeding 1.2 grams of fuel loss in 24 hours per cubic foot of net compartment volume, or
    - (ii) If the net compartment volume is less than one cubic foot, having a permeability rate exceeding 1.2 grams of fuel loss in 24 hours.

*Note: Reference fuel "C" at 40 degrees Celsius plus or minus 2 degrees Celsius from ASTM standard D 471 (incorporated by reference, see Sec. 183.5) is to be used in determining the permeability rate.*

- (b) Each supply opening required in Sec. 183.630 must be located on the exterior surface of the boat.
- (c) An accommodation compartment above a compartment requiring ventilation that is separated from the compartment requiring ventilation by a deck or other structure is excepted from paragraph (a)(2) of this section.

[CGD 76-082, 44 FR 73027, Dec. 17, 1979, as amended by CGD 76-082(a), 46 FR 27645, May 21, 1981; CGD 85-059, 51 FR 37577, Oct. 23, 1986; USCG-1999-5832, 64 FR 34716, June 29, 1999; USCG-1999-5151, 64 FR 67176, Dec. 1, 1999]

#### **Sec. 183.630—Standards for natural ventilation**

- (a) For the purpose of Sec. 183.620, "natural ventilation" means an airflow in a compartment in a boat achieved by having:
- (1) A supply opening or duct from the atmosphere or from a ventilated compartment or from a compartment that is open to the atmosphere; and
  - (2) An exhaust opening into another ventilated compartment or an exhaust duct to the atmosphere.
- (b) Each exhaust opening or exhaust duct must originate in the lower third of the compartment.
- (c) Each supply opening or supply duct and each exhaust opening or exhaust duct in a compartment must be above the normal accumulation of bilge water.

(d) Except as provided in paragraph (e) of this section, supply openings or supply ducts and exhaust openings or exhaust ducts must each have a minimum aggregate internal cross-sectional area calculated as follows:

$$A=5 \ln (V/5);$$

where:

- (1) A is the minimum aggregate internal cross-sectional area of the openings or ducts in square inches;
- (2) V is the net compartment volume in cubic feet, including the net volume of other compartments connected by openings that exceed 2 percent of the area between the compartments; and
- (3)  $\ln (V/5)$  is the natural logarithm of the quantity  $(V/5)$ .

(e) The minimum internal cross-sectional area of each supply opening or duct and exhaust opening or duct must exceed 3.0 square inches.

(f) The minimum internal cross-sectional area of terminal fittings for flexible ventilation ducts installed to meet the requirements of paragraph (d) of this section must not be less than 80 percent of the required internal cross-sectional area of the flexible ventilation duct.

[CGD 76-082, 44 FR 73027, Dec. 17, 1979; 45 FR 7544, Feb. 4, 1980]

### **Subpart L—Start-in-Gear Protection**

*Source: CGD 79-137, 46 FR 3515, Jan. 15, 1981, unless otherwise noted.*

#### **Sec. 183.701—Applicability**

This subpart applies to outboard motors and starting controls, and to manufacturers, distributors or dealers installing such equipment.

[USCG-1999-5832, 64 FR 34716, June 29, 1999]

#### **Sec. 183.705—Definitions**

For the purposes of this subpart:

- (a) Outboard motor means a self-contained propulsion system of any horsepower rating designed to be installed on, and removable from the transom of a boat.
- (b) Static thrust means the forward or backward thrust developed by an outboard motor and associated propulsion unit while stationary.
- (c) Starting control means the motor throttle, shift and starting control mechanisms located at a position remote from the outboard motor.
- (d) Local starting means operating a mechanical or electrical starting device built into the outboard motor.
- (e) Distributor means any person engaged in the sale and distribution of boats or associated equipment for the purpose of resale.



(f) **Dealer** means any person who is engaged in the sale and distribution of boats or associated equipment to purchasers who the seller in good faith believes to be purchasing any such boat or associated equipment for purposes other than resale.

**Sec. 183.710—Start-in-gear protection required**

(a) Any outboard motor which is capable of developing a static thrust of 115 pounds or more at any motor operating speed with any propeller or jet attachment recommended for or shipped with the motor by the manufacturer, must be equipped with a device to prevent the motor being started when controls are set so as to attain that thrust level, as follows:

(1) Outboard motors designed for local starting must have a built-in start-in-gear protection device.

(2) Outboard motors designed for remote starting must have either a built-in start-in-gear protection device or be installed with remote starting controls containing this device. An outboard motor designed for remote starting that does not have a built-in start-in-gear protection device must, at the time of sale, have a tag or label attached at the location of the control connection, containing the following information: "Starting controls installed with this motor must comply with USCG requirements for start-in-gear protection in 33 CFR Part 183, Subpart L." The letters and numbers on the tag or label must be at least 1/8 inch high.

(b) Starting controls must have a tag or label with the following information to indicate whether or not they have been equipped with a start-in-gear protection device: "This control will (or will not) provide start-in-gear protection meeting USCG requirements of 33 CFR Part 183, Subpart L." The letters and numbers on the tag or label must be at least 1/8 inch high.

(c) Any manufacturer, distributor or dealer installing an outboard motor displaying the label described in paragraph (a)(2) of this section must properly match it with a compatible starting control that contains a start-in-gear protection device.

**Sec. 183.715—Exception**

Outboard motors designed to be equipped for remote starting, but which also have a provision for local starting in emergencies, need not comply with Sec. 183.710 for their local starting system. However, the following information must be displayed on the motor: "Warning—Ensure shift control is in neutral before starting motor". This information must be clearly visible to a person using the emergency starting device.

**Subpart M—Navigation Lights**

*Source: USCG-1999-6580, 66 FR 55091, Nov. 1, 2001, unless otherwise noted.*

*Effective Date Note: By USCG-1999-6580, 66 FR 55091, Nov. 1, 2001, Subpart M was added, effective Nov. 1, 2002. At 67 FR 2329, Jan. 17, 2002, the effective date was delayed until Nov. 1, 2003.*

**Sec. 183.801—Applicability**

This subpart applies to recreational vessel manufacturers, distributors, and dealers installing such equipment in new recreational vessels constructed after November 1, 2002.

**Sec. 183.803—Definitions**

As used in this subpart:

**Dealer** means any person who is engaged in the sale and distribution of recreational vessels to purchasers who the seller in good faith believes to be purchasing any such recreational vessel for purposes other than resale.

Distributor means any person engaged in the sale and distribution of recreational vessels for the purpose of resale.

Manufacturer means any person engaged in:

- (1) The manufacture, construction, or assembly of recreational vessels, or
- (2) The importation of recreational vessels into the United States for subsequent sale.

Navigation lights are those lights prescribed by the Navigation Rules (Commandant Instruction 16672.2 series) to indicate a vessel's presence, type, operation, and relative heading.

**Sec. 183.810—Navigation light certification requirements**

- (a) Except as provided by paragraph (b) of this section, each navigation light must—
  - (1) Meet the technical standards of the applicable Navigation Rules;
  - (2) Be certified by a laboratory listed by the Coast Guard to the standards of ABYC A-16 (incorporated by reference, see Sec. 183.5) or equivalent, although portable battery-powered lights need only meet the requirements of the standard applicable to them; and
  - (3) Bear a permanent and indelible label that is visible without removing or disassembling the light and that states the following:
    - (i) “USCG Approval 33 CFR 183.810.”
    - (ii) “MEETS \_\_\_\_\_.” (Insert the identification name or number of the standard under paragraph (a)(2) of this section, to which the laboratory type-tested.)
    - (iii) “TESTED BY \_\_\_\_\_.” (Insert the name or registered certification-mark of the laboratory listed by the Coast Guard that tested the fixture to the standard under paragraph (a)(2) of this section.)
    - (iv) Name of manufacturer.
    - (v) Number of model.
    - (vi) Visibility of the light in nautical miles.
    - (vii) Date on which the light was type-tested.
    - (viii) Identification and specifications of the bulb used in the compliance test.
- (b) If a light is too small to attach the required label—
  - (1) Place the information from the label in or on the package that contains the light; and
  - (2) Mark each light “USCG” followed by the certified range of visibility in nautical miles (nm), for example, “USCG 2nm”. Once installed, this mark must be visible without removing the light.

**Subpart N [Reserved]**

---

**CODE OF FEDERAL REGULATIONS – TITLE 46 – SHIPPING****PART 25—REQUIREMENTS****Subpart 25.01****Application**

- Sec. 25.01-1 Applicable to all vessels
- Sec. 25.01-3 Incorporation by reference
- Sec. 25.01-5 OMB control numbers assigned pursuant to the Paperwork Reduction Act

**Subpart 25.10****Navigation Lights**

- Sec. 25.10-1 Applicability
- Sec. 25.10-2 Definitions
- Sec. 25.10-3 Navigation light certification requirements

**Subpart 25.30****Fire Extinguishing Equipment**

- Sec. 25.30-1 Application
- Sec. 25.30-5 General provisions
- Sec. 25.30-10 Hand portable fire extinguishers and semiportable fire extinguishing systems
- Sec. 25.30-15 Fixed fire extinguishing systems
- Sec. 25.30-20 Fire extinguishing equipment required
- Sec. 25.30-90 Vessels contracted for prior to November 19, 1952

**Subpart 25.35****Backfire Flame Control**

- Sec. 25.35-1 Requirements

**Subpart 25.40****Ventilation**

- Sec. 25.40-1 Tanks and engine spaces

**Subpart 25.45****Cooking, Heating, and Lighting Systems**

- Sec. 25.45-1 Heating and lighting systems on vessels carrying passengers for hire
- Sec. 25.45-2 Cooking systems on vessels carrying passengers for hire

**Subpart 25.01—Application**

**Sec. 25.01-1—Applicable to all vessels**

(a) The provisions of this part shall apply to all vessels except as specifically noted.

**Sec. 25.01-3—Incorporation by reference**

(a) Certain material is incorporated by reference into this part with the approval of the Director of the Federal Register in accordance with 5 U.S.C. 552(a). To enforce any edition other than that specified in paragraph (b) of this section, the Coast Guard must publish notice of change in the Federal Register and make the material available to the public. All approved material is on file at the Office of the Federal Register, 800 North Capitol Street, NW., suite 700, Washington, DC and at the U.S. Coast Guard, Office of Compliance (G-MOC), 2100 Second Street SW., Washington, DC 20593-0001 and is available from the sources indicated in paragraph (b) of this section.

(b) The material approved for incorporation by reference in this part and the sections affected are:

American Boat and Yacht Council (ABYC)  
 3069 Solomons Island Road, Edgewater, MD 21037  
 Standard A-1-78, Marine LPG-Liquefied Petroleum Gas Systems, December 15, 1978: 25.45-2.  
 Standard A-22-78, Marine CNG-Compressed Natural Gas Systems, December 15, 1978: 25.45-2.

National Fire Protection Association (NFPA)  
 1 Batterymarch Park, Quincy, MA 02269  
 NFPA 302, Fire Protection Standard for Pleasure and Commercial Motor Craft, 1989: 25.45-2.

Society of Automotive Engineers (SAE)  
 400 Commonwealth Drive, Warrendale, PA 15096  
 SAE J-1928, Devices Providing Backfire Flame Control for Gasoline Engines in Marine Applications, June 1989: 25.35-1.

Underwriter's Laboratories (UL)  
 12 Laboratory Drive, Research Triangle Park, NC 27709  
 UL 1111, Marine Carburetor Flame Arrestors, June 1988: 25.35-1.

[CGD 88-032, 56 FR 35820, July 29, 1991, as amended by CGD 95-072, 60 FR 50461, Sept. 29, 1995; CGD 95-072, 60 FR 54106, Oct. 19, 1995; CGD 96-041, 61 FR 50726, Sept. 27, 1996]

*Effective Date Note: At 66 FR 55091, Nov. 1, 2001, paragraph (b) was amended by adding a standard, effective Nov. 1, 2002. At 67 FR 2329, Jan. 17, 2002, the effective date was delayed until Nov. 1, 2003. For the convenience of the user, the added text is set forth as follows:*

**Sec. 25.01-3—Incorporation by reference**

(b) Standard A-16-97, Electric Navigation Lights, July 1997.... Sec. 25.10-3.

**Sec. 25.01-5—OMB control numbers assigned pursuant to the Paperwork Reduction Act**

(a) Purpose. This section collects and displays the control numbers assigned to information collection and recordkeeping requirements in this subchapter by the Office of Management and Budget (OMB) pursuant to the Paperwork Reduction Act of 1980 (44 U.S.C. 3501 et seq.). The Coast Guard intends that this section comply with the requirements of 44 U.S.C. 3507(f), which

requires that agencies display a current control number assigned by the Director of the OMB for each approved agency information collection requirement.

(b) Display.

46 CFR part or section where identified or described	Current OMB control No.
Sec. 25.45-2	2115.0549

[CGD 83-013, 54 FR 6401, Feb. 10, 1989 and CGD 83-013, 55 FR 3959, Feb. 6, 1990]

### **Subpart 25.10—Navigation Lights**

#### **Sec. 25.10-1—Applicability**

*Effective Date Note: At 66 FR 55092, Nov. 1, 2001, subpart 25.10 was added, effective Nov. 1, 2002. At 67 FR 2329, Jan. 17, 2002, the effective date was delayed until Nov. 1, 2003.*

This subpart applies to vessel manufacturers, distributors, and dealers installing navigation lights on all uninspected commercial vessels, except those completed before November 7, 2002.

#### **Sec. 25.10-2—Definitions**

As used in this subpart:

Dealer means any person who is engaged in the sale and distribution of vessels to purchasers who the seller in good faith believes to be purchasing any such vessel for purposes other than resale.

Distributor means any person engaged in the sale and distribution of vessels for the purpose of resale.

Manufacturer means any person engaged in:

- (1) The manufacture, construction, or assembly of vessels, or
- (2) The importation of vessels into the United States for subsequent sale.

Navigation lights are those lights prescribed by the Navigation Rules (Commandant Instruction 16672.2 series) to indicate a vessel's presence, type, operation, and relative heading.

#### **Sec. 25.10-3—Navigation light certification requirements**

- (a) Except as provided by paragraph (b) of this section, each navigation light must—
  - (1) Meet the technical standards of the applicable Navigation Rules;
  - (2) Be certified by a laboratory listed by the Coast Guard to the standards of ABYC A-16 (incorporated by reference, see Sec. 25.01-3), or equivalent, although portable battery-powered lights need only meet the requirements of the standard applicable to them; and
  - (3) Bear a permanent and indelible label stating the following:
    - (i) "USCG Approval 33 CFR 183.810"
    - (ii) "MEETS \_\_\_\_\_." (Insert the identification name or number of the standard under paragraph (a)(2) of this section, to which the light was type-tested.)
    - (iii) "TESTED BY \_\_\_\_\_." (Insert the name or registered certification-mark of the laboratory listed by the Coast Guard that tested the fixture to the standard under paragraph (a)(2) of this section.)
    - (iv) Name of Manufacturer.
    - (v) Number of Model.
    - (vi) Visibility of the light in nautical miles (nm).

- (vii) Date on which the light was type-tested.
  - (viii) Identification of bulb used in the compliance test.
- (b) If a light is too small to attach the required label—
- (1) Place the information from the label in or on the package that contains the light; and
  - (2) Mark each light “USCG” followed by the certified range of visibility in nautical miles, for example, “USCG 2nm.” Once installed, this mark must be visible without removing the light.

**Subpart 25.30—Fire Extinguishing Equipment**

**Sec. 25.30-1—Application**

(a) The provisions of this subpart, with the exception of Sec. 25.30-90, shall apply to all vessels contracted for on or after November 19, 1952. Vessels contracted for prior to that date shall meet the requirements of Sec. 25.30-90.

**Sec. 25.30-5—General provisions**

(a) Where equipment in this subpart is required to be of an approved type, such equipment requires the specific approval of the Commandant. Such approvals are published in the Federal Register, and in addition, are contained in Coast Guard publication COMDTINST M16714.3 (Series), Equipment Lists.

(b) All hand portable fire extinguishers, semiportable fire extinguishing systems, and fixed fire extinguishing systems shall be of an approved type.

[CGFR 65-50, 30 FR 16653, Dec. 30, 1965, as amended by CGD 96-041, 61 FR 50726, Sept. 27, 1996]

**Sec. 25.30-10—Hand portable fire extinguishers and semiportable fire extinguishing systems**

(a) Hand portable fire extinguishers and semiportable fire extinguishing systems are classified by a combination letter and number symbol. The letter indicating the type of fire which the unit could be expected to extinguish, and the number indicating the relative size of the unit.

(b) For the purpose of this subchapter, all required hand portable fire extinguishers and semiportable fire extinguishing systems are of the “B” type; i.e., suitable for extinguishing fires involving flammable liquids, greases, etc.

(c) The number designations for size will start with “I” for the smallest to “V” for the largest. For the purpose of this subchapter, only sizes I through III will be considered. Sizes I and II are considered hand portable fire extinguishers and sizes III, IV, and V are considered semiportable fire extinguishing systems which shall be fitted with suitable hose and nozzle or other practicable means so that all portions of the space concerned may be covered. Examples of size graduations for some of the typical hand portable fire extinguishers and semiportable fire extinguishing systems are set forth in Table 25.30-10(c).

**Table 25.30-10(c)**

Classification		Foam, gallons	Carbon Dioxide, pounds	Dry chemical, pounds
Type	Size			
B	I	1-3/4	4	2
B	II	2-1/2	15	10
B	III	12	35	20

- (d) All hand portable fire extinguishers and semiportable fire extinguishing systems shall have permanently attached thereto a metallic name plate giving the name of the item, the rated capacity in gallons, quarts, or pounds, the name and address of the person or firm for whom approved, and the identifying mark of the actual manufacturer.
- (e) Vaporizing-liquid type fire extinguishers containing carbon tetrachloride or chlorobromomethane or other toxic vaporizing liquids are not acceptable as equipment required by this subchapter.
- (f) Hand portable or semiportable extinguishers which are required on their name plates to be protected from freezing shall not be located where freezing temperatures may be expected.
- (g) The use of dry chemical, stored pressure, fire extinguishers not fitted with pressure gauges or indicating devices, manufactured prior to January 1, 1965, may be permitted on motorboats and other vessels so long as such extinguishers are maintained in good and serviceable condition. The following maintenance and inspections are required for such extinguishers:
- (1) When the date on the inspection record tag on the extinguishers shows that 6 months have elapsed since last weight check ashore, then such extinguisher is no longer accepted as meeting required maintenance conditions until reweighed ashore and found to be in a serviceable condition and within required weight conditions.
  - (2) If the weight of the container is  $\frac{1}{4}$  ounce less than that stamped on container, it shall be serviced.
  - (3) If the outer seal or seals (which indicate tampering or use when broken) are not intact, the boarding officer or marine inspector will inspect such extinguisher to see that the frangible disc in neck of the container is intact; and if such disc is not intact, the container shall be serviced.
  - (4) If there is evidence of damage, use, or leakage, such as dry chemical powder observed in the nozzle or elsewhere on the extinguisher, the container shall be replaced with a new one and the extinguisher properly serviced or the extinguisher replaced with another approved extinguisher.
- (h) The dry chemical, stored pressure, fire extinguishers without pressure gauges or indicating devices manufactured after January 1, 1965, shall not be labeled with the marine type label bed in Sec. 162.028-4 of this title nor shall such extinguishers manufactured after January 1, 1965, be carried on board motorboats or other vessels as required equipment.

[CGFR 65-50, 30 FR 16653, Dec. 30, 1965, as amended by CGFR 68-32, 33 FR 5711, Apr. 12, 1968; CGFR 69-18, 34 FR 5723, Mar. 27, 1969]

**Sec. 25.30-15—Fixed fire extinguishing systems**

- (a) When a fixed fire extinguishing system is installed, it shall be of an approved carbon dioxide type, designed and installed in agreement with the applicable provisions of subpart 76.15 of subchapter H (Passenger Vessels) of this chapter.

**Sec. 25.30-20—Fire extinguishing equipment required**

- (a) Motorboats.
- (1) All motorboats shall carry at least the minimum number of hand portable fire extinguishers set forth in Table 25.30-20(a)(1), except that motorboats less than 26 feet in length, propelled by outboard motors and not carrying passengers for hire, need not carry such portable fire extinguishers if the construction of such motorboats will not permit the entrapment of explosive or flammable gases or vapors.

**Table 25.30-20(a)(1)**

Length, feet	Minimum number of B-1 hand portable fire extinguishers required <sup>1</sup>	
	No fixed fire extinguishing system in machinery space	Fixed fire extinguishing system in machinery space
Under 16	1	0
16 and over, but under 26	1	0
26 and over, but under 40	2	1
40 and over, but not over 65	3	2

<sup>1</sup> One B-11 hand portable fire extinguisher may be substituted for two B-1 hand portable fire extinguishers.

(2) The intent of this regulation is illustrated in Figure 25.30-20(a1) where fire extinguishers are required if any one or more of the specified conditions exist, and in Figure 25.30-20(a2) where specified conditions do not, in themselves, require that fire extinguishers be carried.

**Figure 25.30-20(a1)**

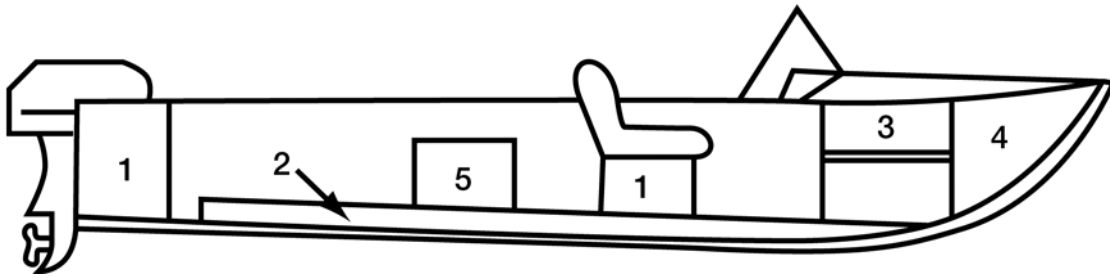

Fire extinguishers are required if any one or more of the following conditions exist (numbers identifying conditions are the same as those placed in Figure 25.30-20 (a1)):

1. Closed compartment under thwarts and seats wherein portable fuel tanks may be stored.
2. Double bottoms not sealed to the hull or which are not completely filled with flotation material.
3. Close living spaces.
4. Closed stowage compartments in which combustible or flammable materials are stowed.
5. Permanently installed fuel tanks.

**Figure 25.30-20(a2)**

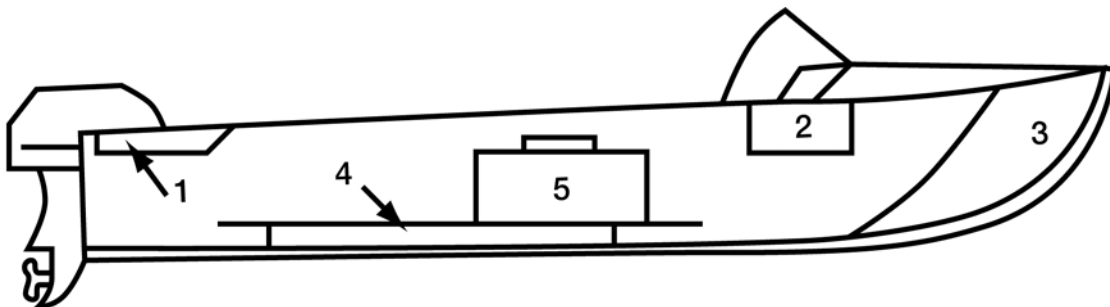



The following conditions do not, in themselves, require that fire extinguishers be carried (numbers identifying conditions are the same as those placed in Figure 25.30-20(a2)):

1. Bait wells.
2. Glove compartments.
3. Buoyant flotation material.
4. Open slatted flooring.
5. Ice chests.

(b) Uninspected passenger vessels of at least 100 gross tons. All uninspected passenger vessels of at least 100 gross tons must carry onboard hand-portable and semi-portable fire extinguishers per Table 76.50-10(a) in Sec. 76.50-10 of this chapter.

(c) Motor vessels.

- (1) All motor vessels shall carry at least the minimum number of hand portable fire extinguishers set forth in Table 25.30-20(b) (1).

**Table 25.30-20(b)(1)**

Gross tonnage—		Minimum number of B-II hand portable fire extinguishers
Over	Not over	
.....	50	1
50	100	2
100	500	3
500	1,000	6
1,000	.....	8

(2) In addition to the hand portable fire extinguishers required by paragraph (b)(1) of this section, the following fire-extinguishing equipment shall be fitted in the machinery space:

- (i) One Type B-II hand portable fire extinguisher shall be carried for each 1,000 B. H. P. of the main engines or fraction thereof. However, not more than 6 such extinguishers need be carried.
- (ii) On motor vessels of over 300 gross tons, either one Type B-III semiportable fire-extinguishing system shall be fitted, or alternatively, a fixed fire-extinguishing system shall be fitted in the machinery space.

(3) The frame or support of each Type B-III fire extinguisher required by paragraph (b)(2)(ii) of this section must be welded or otherwise permanently attached to a bulkhead or deck.

(4) If an approved semiportable fire extinguisher has wheels and is not required by this section, it must be securely stowed when not in use to prevent it from rolling out of control under heavy sea conditions.

(d) Barges carrying passengers.

(1) Every barge of 65 feet in length or less while carrying passengers when towed or pushed by a motorboat, motor vessel, or steam vessel shall be fitted with hand portable fire extinguishers as required by Table 25.30-20(a)(1), depending upon the length of the barge.

(2) Every barge of over 65 feet in length while carrying passengers when towed or pushed by a motorboat, motor vessel, or steam vessel shall be fitted with hand portable fire extinguishers as required by Table 25.30-20(b)(1), depending upon the gross tonnage of the barge.

[CGFR 65-50, 30 FR 16653, Dec. 30, 1965, as amended by CGD 77-039, 44 FR 34132, June 14, 1979; CGD 97-057, 62 FR 51042, Sept. 30, 1997; USCG-1999-5040, 67 FR 34776, May 15, 2002]

**Sec. 25.30-90—Vessels contracted for prior to November 19, 1952**

(a) Vessels contracted for prior to November 19, 1952, shall meet the applicable provisions of Secs. 25.30-5 through 25.30-20 insofar as the number and general type of equipment is concerned. Existing items of equipment and installations previously approved but not meeting the applicable requirements for type approval may be continued in service so long as they are in good condition. All new installations and replacements shall meet the requirements of Secs. 25.30-5 through 25.30-20.

(b) [Reserved]

**Subpart 25.35—Backfire Flame Control****Sec. 25.35-1—Requirements**

(a) Every gasoline engine installed in a motorboat or motor vessel after April 25, 1940, except outboard motors, shall be equipped with an acceptable means of backfire flame control.

(b) Installations made before November 19, 1952, need not meet the detailed requirements of this subpart and may be continued in use as long as they are serviceable and in good condition. Replacements shall meet the applicable conditions in this section.

(c) Installations consisting of backfire flame arresters bearing basic Approval Nos. 162.015 or 162.041 or engine air and fuel induction systems bearing basic Approval Nos. 162.015 or 162.042 may be continued in use as long as they are serviceable and in good condition. New installations or replacements must meet applicable requirements of subpart 58.10 of this chapter.

[CGFR 65-50, 30 FR 16653, Dec. 30, 1965, as amended by CGD 88-032, 56 FR 35820, July 29, 1991]

**Subpart 25.40—Ventilation****Sec. 25.40-1—Tanks and engine spaces**

(a) All motorboats or motor vessels, except open boats and as provided in paragraphs (d) and (e) of this section, the construction or decking over of which is commenced after April 25, 1940, and which use fuel having a flashpoint of 110[deg] F., or less, shall have at least two ventilator ducts, fitted with cowls or their equivalent, for the efficient removal of explosive or flammable gases from the bilges of every engine and fuel tank compartment. There shall be at least one exhaust duct installed so as to extend from the open atmosphere to the lower portion of the bilge and at least one intake duct installed so as to extend to a point at least midway to the bilge or at least below the level of the carburetor air intake. The cowls shall be located and trimmed for maximum effectiveness and in such a manner so as to prevent displaced fumes from being recirculated.

(b) As used in this section, the term open boats means those motorboats or motor vessels with all engine and fuel tank compartments, and other spaces to which explosive or flammable gases and vapors from these compartments may flow, open to the atmosphere and so arranged as to prevent the entrapment of such gases and vapors within the vessel.

(c) Boats built after July 31, 1980, which are manufactured or used primarily for noncommercial use; which are leased, rented, or chartered to another for the latter's noncommercial use; which are engaged in the carriage of six or fewer passengers; or which are in compliance with the requirements of 33 CFR part 183 are exempted from these requirements.

- (d) Boats built after July 31, 1978, which are manufactured or used primarily for noncommercial use; which are rented, leased, or chartered to another for the latter's noncommercial use; or which engage in conveying six or fewer passengers are exempted from the requirements of paragraph (a) for fuel tank compartments that:
- (1) Contain a permanently installed fuel tank if each electrical component is ignition protected in accordance with 33 CFR 183.410(a); and
  - (2) Contain fuel tanks that vent to the outside of the boat.

[CGFR 65-50, 30 FR 16653, Dec. 30, 1965, as amended by CGD 76-082A, 44 FR 73047, Dec. 17, 1979; CGD 76-082A, 45 FR 7551, Feb. 4, 1980; CGD 95-012, 60 FR 48048, Sept. 18, 1995; CGD 95-028, 62 FR 51196, Sept. 30, 1997]

**Subpart 25.45—Cooking, Heating, and Lighting Systems**

**Sec. 25.45-1—Heating and lighting systems on vessels carrying passengers for hire**

- (a) No fuel may be used in any heating or lighting system on any vessel carrying passengers for hire without the approval of Commandant (G-MSE), except—
- (1) Alcohol, solid,
  - (2) Alcohol, liquid, combustible,
  - (3) Fuel oil, No. 1, No. 2, or No. 3,
  - (4) Kerosene,
  - (5) Wood or,
  - (6) Coal.
- (b) Heating and lighting systems using alcohol must meet the following requirements:
- (1) Containers of solidified alcohol must be properly secured to a fixed base.
  - (2) Fluid alcohol burners, where wet priming is used, must have—
    - (i) A catch pan of not less than 3/4" depth secured inside the frame of the stove; or
    - (ii) The metal protection under the stove flanged up at least 3/4" to form a pan.
- (c) Heating and lighting systems using kerosene or fuel oil must meet the following requirements:
- (1) Where wet priming is used, each system must have—
    - (i) A catch pan of not less than 3/4" depth secured inside the frame of the stove; or
    - (ii) The metal protection under the stove flanged up at least 3/4" to form a pan.
  - (2) Fuel tanks must be—
    - (i) Separated from the stove that they serve;
    - (ii) Mounted in a location open to the atmosphere or mounted inside a compartment that is vented to the atmosphere; and
    - (iii) Fitted with an outside fill and vent.
- (d) Heating systems using wood or coal installed after August 9, 1989, shall be installed in accordance with the guidelines in chapter 6 of NFPA 302.

[CGD 83-013, 54 FR 6402, Feb. 10, 1989 and CGD 83-013, 55 FR 3959, Feb. 6, 1990; CGD 95-072, 60 FR 50461, Sept. 29, 1995; CGD 96-041, 61 FR 50726, Sept. 27, 1996]

**Sec. 25.45-2—Cooking systems on vessels carrying passengers for hire**

- (a) No fuel may be used in any cooking system on any vessel carrying passengers for hire without the approval of Commandant (G-MSE) except those listed in Sec. 25.45-1, subject to the requirements stated therein, and liquefied petroleum gas (LPG), or compressed natural gas (CNG).

- (b) Cooking systems using LPG or CNG must meet the following requirements:
- (1) The design, installation, and testing of each LPG system must meet ABYC A-1-78 or Chapter 6 of NFPA 302.
  - (2) The design, installation, and testing of each CNG system must meet ABYC A-22-78 or Chapter 6 of NFPA 302.
  - (3) Cooking systems using chapter 6 of NFPA 302 as the standard must meet the following additional requirements:
    - (i) The storage or use of CNG containers within the accommodation area, machinery spaces, bilges, or other enclosed spaces is prohibited.
    - (ii) LPG or CNG must be odorized in accordance with ABYC A-1.5.d or A-22.5.b, respectively.
    - (iii) The marking and mounting of LPG cylinders must be in accordance with ABYC A-1.6.b.
    - (iv) LPG cylinders must be of the vapor withdrawal type as specified in ABYC A-1.5.b.
  - (4) Continuous pilot lights or automatic glow plugs are prohibited for an LPG or CNG installation using ABYC A-1 or A-22 as the standard.
  - (5) CNG installations using ABYC A-22 as the standard must meet the following additional requirements:
    - (i) The stowage or use of CNG containers within the accommodation area, machinery spaces, bilges, or other enclosed spaces is prohibited.
    - (ii) The CNG cylinders, regulating equipment, and safety equipment must meet the installation, stowage, and testing requirements specified in paragraph 6-5.12 of NFPA 302.
    - (iii) The use of stowage of stoves with attached CNG cylinders is prohibited as specified in paragraph 6-5.1 of NFPA 302.
  - (6) If the fuel supply line of an LPG or CNG system enters an enclosed space on the vessel, a remote shut-off valve must be installed that can be operated from a position adjacent to the appliance. The valve must be located between the fuel tank and the point where the fuel supply line enters the enclosed portion of the vessel. A power operated valve installed to meet this requirement must be of a type that will fail closed.
  - (7) The following variances from ABYC A-1.11.b(1) are allowed for CNG:
    - (i) The storage locker or housing access opening need not be in the top.
    - (ii) The locker or housing need not be above the waterline.
  - (8) The following variances from NFPA 302 are allowed:
    - (i) The storage locker or housing for CNG tank installations need not be above the waterline as required by paragraph 6-5.12.1.1(a).
    - (ii) Ignition protection need not be provided as required by paragraph 6-5.4.

*Note to Sec. 25.45-2: The ABYC and NFPA standards referenced in this section require the posting of placards containing safety precautions for gas cooking systems.*

[CGD 83-013, 54 FR 6402, Feb. 10, 1989, as amended by CGD 83-013, 55 FR 3960, Feb. 6, 1990; CGD 95-072, 60 FR 50461, Sept. 29, 1995; CGD 96-041, 61 FR 50726, Sept. 27, 1996; USCG-2000-7790, 65 FR 58458, Sept. 29, 2000]

**CODE OF FEDERAL REGULATIONS – TITLE 46 – SHIPPING**

**PART 58—MAIN AND AUXILIARY MACHINERY AND RELATED SYSTEMS**

**Subpart 58.03**      ***Incorporation of Standards***  
 Sec. 58.03-1      Incorporation by reference

**Subpart 58.10**      ***Internal Combustion Engine Installations***  
 Sec. 58.10-5      Gasoline engine installations

**Subpart 58.03—Incorporation of Standards**

**Sec. 58.03-1—Incorporation by reference**

(a) Certain material is incorporated by reference into this part with the approval of the Director of the Federal Register in accordance with 5 U.S.C. 552(a). To enforce any edition other than that specified in paragraph (b) of this section, the Coast Guard must publish notice of change in the Federal Register and make the material available to the public. All approved material is on file at the Office of the Federal Register, 800 North Capitol Street, NW., suite 700, Washington, DC, and at the U.S. Coast Guard, Office of Design and Engineering Standards (G-MSE), 2100 Second Street SW., Washington, DC 20593-0001 and is available from the sources indicated in paragraph (b) of this section.

(b) The material approved for incorporation by reference in this part and the sections affected are:

American Boat and Yacht Council (ABYC)  
 3069 Solomons Island Road, Edgewater, MD 21037  
 P-1-73, Safe Installation of Exhaust Systems for Propulsion and Auxiliary Machinery, 1973: 58.10-5.

American Bureau of Shipping (ABS)  
 ABS Plaza, 16855 Northchase Drive, Houston, TX 77060  
 Rules for Building and Classing Steel Vessels, 1989:  
58.01-5; 58.05-1; 58.10-15; 58.20-5; 58.25-5.

American National Standards Institute (ANSI)  
 11 West 42nd Street, New York, NY 10036  
 ANSI B31.3, Chemical Plant and Petroleum Refinery Piping, 1987: 58.60-7.  
 ANSI B31.5, Refrigeration Piping, 1987: 58.20-5; 58.20-20.  
 ANSI B93.5, Recommended practice for the use of Fire Resistant Fluids for Fluid Power Systems, 1979: 58.30-10.

American Petroleum Institute (API)  
 1220 L Street NW., Washington, DC 20005-4070.  
 API RP 14C, Analysis, Design, Installation and Testing of Basic Surface Safety Systems for Offshore Production Platforms, 1986: 58.60-9.  
 API RP 53, Recommended Practice for Blowout Prevention Equipment Systems for Drilling Wells, 1984: 58.60-7.

American Society of Mechanical Engineers (ASME) International  
 Three Park Avenue, New York, NY 10016-5990.  
 Boiler and Pressure Vessel Code, Section I, Power Boilers, July 1989 with 1989 addenda: 58.30-15.  
 Section VIII, Division 1, Pressure Vessels, July 1989 with 1989 addenda: 58.30-15.

American Society for Testing and Materials (ASTM)

100 Barr Harbor Drive, West Conshohocken, PA 19428-2959.

ASTM A 193/A 193M-98a, Standard Specification for Alloy-Steel and Stainless Steel Bolting Materials for High-Temperature Service: 58.30-15.

ASTM B 96-93, Standard Specification for Copper-Silicon Alloy Plate, Sheet, Strip, and Rolled Bar for General Purposes and Pressure Vessels: 58.50-5.

ASTM B 122/B 122M-95, Standard Specification for Copper-Nickel-Tin Alloy, Copper-Nickel-Zinc Alloy (Nickel Silver), and Copper-Nickel Alloy Plate, Sheet, Strip, and Rolled Bar: 58.50-5.

ASTM B 152-97a, Standard Specification for Copper Sheet, Strip, Plate, and Rolled Bar: 58.50-5.

ASTM B 209-96, Standard Specification for Aluminum and Aluminum-Alloy Sheet and Plate: 58.50-5; 58.50-10.

ASTM D 92-97, Standard Test Method for Flash and Fire Points by Cleveland Open Cup: 58.30-10.

ASTM D 93-97, Standard Test Methods for Flash Point by Pensky-Martens Closed Cup Tester: 58.01-10.

ASTM D 323-94, Standard Test Method for Vapor Pressure of Petroleum Products (Reid Method): 58.16-5.

International Maritime Organization (IMO)

Publications Section, 4 Albert Embankment, London SE1 7SR, United Kingdom

A.467(XII), Guidelines for Acceptance of Non-Duplicated Rudder Actuators for Tankers, Chemical Tankers and Gas Carriers of 10,000 Tons Gross Tonnage and Above But Less Than 100,000 Tonnes Deadweight, 1981: 58.25-60.

A.468(XII), Code on Noise Levels on Board Ships, 1981: 58.01-50.

Military Specifications (MIL-SPEC)

Naval Publication and Forms Center, Code 1052,

5801 Tabor Avenue, Philadelphia, PA 19120

MIL-S-901, Requirements for High Impact Shock Tests of Shipboard Machinery Equipment and Systems, 1963: 58.30-17.

National Fire Protection Association (NFPA)

1 Batterymarch Park, Quincy, MA 02269

NFPA 302, Fire Protection Standard for Pleasure and Commercial Craft, 1989: 58.10-5.

Society of Automotive Engineers (SAE)

400 Commonwealth Drive, Warrendale, PA 15096

SAE J-1928, Devices Providing Backfire Flame Control for Gasoline Engines in Marine Applications, 1989: 58.10-5.

Underwriters Laboratories, Inc. (UL)

12 Laboratory Drive, Research Triangle Park, NC 27709

UL 1111, Marine Carburetor Flame Arresters, 1988: 58.10-5.

[CGD 88-032, 56 FR 35823, July 29, 1991, as amended by CGD 83-043, 60 FR 24776, May 10, 1995; CGD 95-012, 60 FR 48050, Sept. 18, 1995; CGD 95-072, 60 FR 50462, Sept. 29, 1995; CGD 96-041, 61 FR 50728, Sept. 27, 1996; CGD 97-057, 62 FR 51044, Sept. 30, 1997; USCG-1999-6216, 64 FR 53224, Oct. 1, 1999; USCG-1999-5151, 64 FR 67180, Dec. 1, 1999; USCG-2000-7790, 65 FR 58460, Sept. 29, 2000]

## **Subpart 58.10—Internal Combustion Engine Installations**

### **Sec. 58.10-5—Gasoline engine installations**

(a) Engine design. All installations shall be of marine type engines suitable for the intended service, designed and constructed in conformance with the requirements of this subchapter.

(b) Carburetors.

(1) Drip collectors shall be fitted under all carburetors, except the down-draft type, to prevent fuel leakage from reaching the bilges and so arranged as to permit ready removal of such fuel leakage. Drip collectors shall be covered with flame screens.

*Note: It is recommended that drip collectors be drained by a device for automatic return of all drip to engine air intakes.*

(2) All gasoline engines must be equipped with an acceptable means of backfire flame control. Installations of backfire flame arresters bearing basic Approval Nos. 162.015 or 162.041 or engine air and fuel induction systems bearing basic Approval Nos. 162.015 or 162.042 may be continued in use as long as they are serviceable and in good condition. New installations or replacements must meet the applicable requirements of this section.

(3) The following are acceptable means of backfire flame control for gasoline engines:

(i) A backfire flame arrester complying with SAE J-1928 or UL 1111 and marked accordingly. The flame arrester must be suitably secured to the air intake with a flamtight connection.

(ii) An engine air and fuel induction system which provides adequate protection from propagation of backfire flame to the atmosphere equivalent to that provided by an acceptable backfire flame arrester. A gasoline engine utilizing an air and fuel induction system, and operated without an approved backfire flame arrester, must either include a reed valve assembly or be installed in accordance with SAE J-1928.

(iii) An arrangement of the carburetor or engine air induction system that will disperse any flames caused by engine backfire. The flames must be dispersed to the atmosphere outside the vessel in such a manner that the flames will not endanger the vessel, persons, on board, or nearby vessels and structures. Flame dispersion may be achieved by attachments to the carburetor or location of the engine air induction system. All attachments must be of metallic construction with flamtight connections and firmly secured to withstand vibration, shock, and engine backfire. Such installations do not require formal approval and labeling but must comply with this subpart.

(c) Exhaust manifold. The exhaust manifold shall either be water-jacketed and cooled by discharge from a pump which operates whenever the engine is running, or woodwork within nine inches shall be protected by  $\frac{1}{4}$ -inch asbestos board covered with not less than No. 22 USSG (U.S. standard gage) galvanized sheet iron or nonferrous metal. A dead air space of  $\frac{1}{4}$ -inch shall be left between the protecting asbestos and the wood, and a clearance of not less than two inches maintained between the manifold and the surface of such protection.

(d) Exhaust pipe.

(1) Exhaust pipe installations shall conform to the requirements of the American Boat and Yacht Council Standard P-1 "Safe Installation for Exhaust Systems" and National Fire Protection Association Standard NFPA 302, part 1, section 23 and the following additional requirements:

(i) All exhaust installations with pressures in excess of 15 pounds per square inch gage or employing runs passing through living or working spaces shall meet the material requirements of part 56 of this subchapter.

(ii) Horizontal dry exhaust pipes are permitted only if they do not pass through living or berthing spaces, they terminate above the deepest load waterline and are so arranged as to prevent entry of cold water from rough or boarding seas, and they are constructed of corrosion resisting material “at the hull penetration.”

[CGFR 68-82, 33 FR 18878, Dec. 18, 1968, as amended by CGD 88-032, 56 FR 35824, July 29, 1991]