

BOATBUILDER'S HANDBOOK

[REVISED NOVEMBER, 2003]



*Produced Under A Grant From
The Aquatic Resources (Wallop-Breaux) Trust Fund
Administered By The U.S. Coast Guard.*

SUBPART F

FLOTATION REQUIREMENTS

For Inboard Boats, Inboard/Outdrive Boats and Airboats

Revised November, 2003

SUBPART G

FLOTATION REQUIREMENTS

For Outboard Boats Rated for Engines of More Than 2 Horsepower

Revised November, 2003

SUBPART H

FLOTATION REQUIREMENTS

For Outboard Boats Rated for Engines of 2 Horsepower or Less

Revised November, 2003

Title 33 CFR, Sections 183.101–183.335

WARNING:

This guide only addresses provisions of the Federal Regulations. It is NOT a complete engineering manual for the design of boat systems. It is the manufacturer's responsibility to ensure Federal Regulations cited in this guide have not been updated or revised.

Table of Contents

SECTION	DESCRIPTION	PAGE
	Introduction	1
1.0	Applicability	2
1.1	Subpart F (183.101–183.114) — Inboard Boats, Inboard/Outdrive Boats, and Airboats	2
1.2	Subpart G (183.201–183.235) — Outboard Boats Rated for More Than 2 HP	3
1.3	Subpart H (183.301–183.335) — Outboard Boats Rated for 2 HP or Less	4
2.0	Definitions	5
2.1	Subpart F — Flotation Requirements for Inboards, Sterndrives and Airboats	6
2.2	Subpart G — Flotation Requirements for Outboard Boats Rated for Engines of More Than 2 Horsepower	7
2.3	Subpart H — Flotation Requirements for Outboard Boats Rated for Engines of 2 Horsepower or Less	9
3.0	Preconditioning	16
3.1	Subpart F — Inboard Boats, Inboard/Outdrive (Sterndrive) and Airboats	17
3.2	Subpart G — Outboard Boats Rated for More Than 2 Horsepower	17
3.3	Subpart H — Flotation Requirements for Outboard Boats Rated for Engines of 2 Horsepower or Less	19
4.0	Basic Flotation	20
4.1	Example of Basic Flotation Calculations	23
4.2	Summary of Basic Flotation Performance Requirements	25
5.0	Level Flotation	26
5.1	Example of Level Flotation Calculations	36
5.2	Summary of Level Flotation Requirements and Tests	39
6.0	Modified Level Flotation	48
6.1	Example of Modified Flotation Calculations	50
6.2	Summary of Modified Flotation Requirements and Tests	52
7.0	Flotation Materials	55
7.1	Requirements	56
7.2	Flotation Material Tests	57
7.3	Installation Requirements	60
Appendix A	33 CFR Part 183, Table 4: Weight (Pounds) of Outboard Motor and Related Equipment for Various Horsepower Ratings	66
Appendix B	33 CFR Subpart H, Figures 2–13	67
References		68

List of Federal Regulations

Section	Title	Page
Subpart F	Flotation Requirements Inboards, Inboard/Outdrive, and Airboats	
183.101	Applicability	2
183.105	Quantity of flotation required	20
183.110	Definitions	6
183.112	Flotation material and air chambers	56
183.114	Test of flotation materials	57
Subpart G	Flotation Requirements for Outboard Boats Rated for Engines of More Than 2 Horsepower	
183.201	Applicability	3
183.202	Flotation and certification requirements	26
183.205	Passenger carrying area	7
183.210	Reference areas	8
183.215	Reference depth	8
183.220	Preconditioning for tests	17
183.222	Flotation material and air chambers	56
183.225	Flotation test for persons capacity	39
183.230	Stability test	42
183.235	Level flotation test without weights for capacity	47
Subpart H	Flotation Requirements for Outboard Boats Rated for Engines of 2 Horsepower or Less	
183.301	Applicability	4
183.302	Flotation requirements	48
183.305	Passenger carrying area	9
183.310	Reference areas	9
183.315	Reference depth	10
183.320	Preconditioning for tests	19
183.322	Flotation materials	56
183.325	Flotation test for persons capacity	52
183.330	Stability test	52
183.335	Level flotation test without weights for persons capacity	54
183.516	Cellular plastic used to encase fuel tanks	59
Table 4	Weight (Pounds) of Outboard Motor and Related Equipment for Various Boat Horsepower Ratings	66
Figures 2–13		67

Introduction

This guide is intended to help a boat manufacturer comply with the flotation requirements for certain boats. Compliance with these requirements IS THE RESPONSIBILITY of the boat manufacturer. This guide shows the calculations necessary for design and production considerations, and describes the test methods necessary to achieve and confirm compliance.

The methods of calculating the amount of flotation material needed are included and usually work toward the safe side; in other words, they will result in a little more than the regulation requires rather than a little less. As an example, using the formulas to determine the amount of flotation material necessary to provide for the persons capacity in Basic and Modified Basic flotation, this Guideline calls for 0.25 of the persons capacity, whereas the regulation calls for 2/15ths, which is about 0.133. Using the formulas contained in this Guideline will always meet the requirements of the regulations and will often exceed them.

CAUTION:

This guideline only addresses provisions of the Federal Regulations. It is not a complete engineering manual for the design of electrical systems on boats. There are other manuals and standards available for this purpose.

NOTE:

The formulas and methods contained in this Guideline do not alter, modify, supersede or otherwise replace the requirements of the federal regulations now in effect.

FORMAT

Because the wording of the regulation may be difficult to understand, this guide is written in somewhat simple terms. It is organized in a manner in which the reader (presumably the boat manufacturer) can go directly to the section dealing with the type of boat to be built following a review of Sections 1.0 — *Applicability* and 2.0 — *Definitions*. There are different flotation requirements for different types of boats and we address the specific tests each type of boat must pass.

It is recommended that Section 1 be read first so that a general idea of the requirements can be obtained — particularly since it relates to the applicability of the regulations. Then read Section 2.0 — *Definitions*, since these may vary from similar definitions in other contexts. Next, deal only with your boat type — either Section 4.0, 5.0, or 6.0. This will make the flotation requirements much easier to understand. Finally, review the flotation material requirements described in Section 7.

There are three types or modes of flotation requirements, namely: Basic Flotation, Level Flotation, and Modified Level Flotation. Each one has its own requirements and specific tests. This Guideline is organized in an easy-to-follow format. Each subpart describes the boats included, explains the general requirements for these boats, and lists the type of flotation necessary in each. Based on the type of boat, the reader can determine what flotation is required by going directly to the appropriate section in the Guideline.

1.0 Applicability

Since the regulation is divided according to boat type, the applicability for the various types is discussed in each subpart. The exceptions, however, apply to all subparts and are as follows:

Sailboats, canoes, kayaks, inflatable boats, submersibles, surface effect vessels, amphibious vessels, multi-hull boats and race-boats need not comply.

Following is a summary of the applicability by boat type and subpart.

<u>Subpart</u>	<u>Boat types</u>	<u>Flotation Required</u>
F	<i>Inboards, Inboard/Outdrives And Air Boats</i>	BASIC FLOTATION
G	<i>Outboard Boats Rated for More Than 2 Horsepower</i>	LEVEL FLOTATION
H	<i>Outboard Boats Rated for 2 Horsepower or Less and Manually Propelled Boats</i>	MODIFIED LEVEL FLOTATION

NOTE:

Certain catamarans may be considered as mono-hull boats for the purpose of this regulation. For example, the waterline of some catamaran designs will form a single closed curve when the boat is loaded with the maximum rated horsepower engine and the maximum weight capacity. These boats will be considered by the USCG as mono-hulls and must comply with the flotation requirements.

1.1 Subpart F — Flotation Requirements for Inboards, Inboard/Outdrive, and Airboats

FEDERAL LAW:

183.101 Applicability.

This subpart applies to monohull inboard boats, inboard/outdrive boats, and airboats less than 20 feet in length, except sailboats, canoes, kayaks, inflatable boats, submersibles, surface effect vessels, amphibious vessels, and raceboats.

Discussion:

Monohull inboard, inboard/outboard boats and airboats less than 20 feet in length must comply with a flotation system called **Basic Flotation**. Section 4.0 contains the requirements and tests. Basic flotation is the simplest type of flotation mode covered in this regulation. It simply requires that the boat be manufactured with sufficient flotation material to keep it afloat in the event of a swamping. It does not, however, require that the boat remain in an upright or indeed any specific position. It may float, and usually does, in a “spear” position, the bow sticking up and the stern sunk. The requirements include some materials tests. Section 4.0 covers this type of flotation.

1.2 Subpart G — Flotation Requirements for Outboard Boats Rated for Engines of More Than 2 Horsepower**FEDERAL LAW:**

183.201 Applicability.

- (a) This subpart applies to monohull outboard boats that are:
- (1) Less than 20 feet in length; and
 - (2) Rated for outboard engines of more than 2 horsepower.
- (b) This subpart does not apply to sailboats, canoes, kayaks, inflatable boats, submersibles, surface effect vessels, amphibious vessels, and raceboats.

Discussion:

Monohull boats under 20 feet in length and rated for more than two horsepower must comply with the more sophisticated flotation system called Level Flotation. The **Level Flotation** system requires that the swamped boat, loaded with certain weights representing weight capacity, part of persons capacity and some equipment, must float in an approximately level position and not heel past a certain angle, even when part of the passengers’ weight is on one side of the passenger carrying area. Section 5.0 covers the requirements and tests to perform.

1.3 Subpart H — Flotation Requirements for Outboard Boats Rated for Engines of 2 Horsepower or Less

FEDERAL LAW:

183.301 Applicability.

(a) This subpart applies to monohull outboard boats that are:

(1) Less than 20 feet in length; and

(2) Rated for manual propulsion or outboard engines of 2 horsepower or less.

(b) This subpart does not apply to sailboats, canoes, kayaks, inflatable boats, submersibles, surface effect vessels, amphibious vessels, and raceboats.

Discussion:

Manually propelled boats and boats rated for outboard engines of 2 HP or less must comply with the **Modified Level Flotation** requirements. As the name suggests, Modified Level Flotation is similar to Level Flotation, but with variations in the persons weight and capacity weight numbers. Section 6.0 discusses the calculations, tests and other requirements.

NOTE:

Level Flotation may also be applied to inboard boats, outboard boats of less than 2 HP, and non-powered boats. Nothing in the regulation says that a boat may not be manufactured to comply with a flotation system superior to the one required. These are only minimum requirements. Many manufacturers choose to install Level Flotation in boats that do not require it.

2.0 Definitions

Every definition contained herein shall be assumed to be preceded by the following statement: "For the purpose of this guideline, we will use the following definitions:"

NOTE:

In the event of a question of interpretation of these definitions, consult with the United States Coast Guard.

Mono-hull: any vessel on which, when it is at rest and carries its maximum rated horsepower capacity and maximum weight capacity, the line of intersection of the water surface and the hull forms a single closed curve. For example: a catamaran, trimaran or pontoon boat is not a mono-hull boat. However, it is important to observe that some small catamarans, when loaded, do form a single water line and must be considered mono-hulls.

Race boat: Any vessel which is manufactured solely for use in sanctioned racing events, and is not intended for use as a recreational boat.

Sailboat: A boat designed or intended to use sails as the primary means of propulsion.

Basic Flotation: A flotation system which will keep a swamped boat from sinking when its passengers are in the water clinging to it, provided that the aggregate weight of the motor, passengers and equipment carried in or attached to the boat does not exceed the boat's maximum weight capacity. With Basic Flotation, the swamped boat may float at any attitude.

Level Flotation: A flotation system that will keep a swamped boat and a specified quantity of the weights of its motor, equipment and passengers floating in an approximately level attitude. Sufficient stability is provided to prevent the swamped craft from capsizing in calm water when one-half of the passengers are evenly distributed at one side of the passenger carrying area and as low as possible in the boat. *Level Flotation does not provide a self-righting capability.*

Modified Level Flotation: A flotation system that provides level flotation, as defined here, but with a reduction in the quantity of flotation required for passengers.

Dead Weight: For **inboards**, sterndrives and airboats, the maximum weight capacity marked on the boat, minus the persons capacity marked on the boat.

Horsepower Capacity: The maximum recommended horsepower capacity of a boat as stated on the boat's capacity plate.

Passenger Carrying Area: [see 183.205 & 183.305] Each area in a boat in which persons can sit in a normal sitting position or stand while the boat is in operation. Figures 2.1 to 2.5 explain the passenger carrying area for different boat configurations.

2.1 Subpart F — Flotation Requirements for Inboards, Sterndrives and Airboats

FEDERAL LAW:

183.110 Definitions.

For the purpose of this subpart:

- Bilge means the area in the boat, below a height of 4 inches measured from the lowest point in the boat where liquid can collect when the boat is in its static floating position, except engine rooms.
- Connected means allowing a flow of water in excess of one-quarter ounce per hour from the engine room bilge into any other compartment with a 12-inch head of water on the engine room side of the bulkhead.
- Engine room bilge means the area in the engine room or a connected compartment below a height of 12 inches measured from the lowest point where liquid can collect in these compartments when the boat is in its static floating position.
- Engine room means the compartment where a permanently installed gasoline or diesel engine is installed, including connected compartments.
- Open to atmosphere means a compartment that has at least 15 square inches of open area directly exposed to the atmosphere for each cubic foot of net compartment volume.
- Sealed compartment means an enclosure that can resist an exterior water level of 12 inches without seepage of more than one-quarter fluid ounce per hour.

2.2 Subpart G — Flotation Requirements for Outboard Boats Rated for Engines of More Than 2 Horsepower

FEDERAL LAW:

- 183.205 Passenger carrying area.
- (a) For the purpose of this section a boat is level when it is supported on its keel at the two points shown in Figure 2.
 - (b) As used in this subpart, the term “passenger carrying area” means each area in a boat in which persons can sit in a normal sitting position or stand while the boat is in operation. Passenger carrying areas are illustrated in Figures 3 through 8.
 - (c) The length of the passenger carrying area is the distance along the centerline of the boat between two vertical lines, one at the forward end and one at the aft end of the passenger carrying area when the boat is level as illustrated in Figures 3 and 4. For boats with a curved stem inside the passenger carrying area, the forward vertical line is where a line 45 degrees to the horizontal when the boat is level is tangent to the curve of the stem, as illustrated in Figure 5. For boats with cabins, the forward vertical line is where there is a minimum distance of two feet between the inside top of the cabin and the water line formed when the boat is swamped and loaded with weights under Sec. 183.220 as illustrated in Figure 6.
 - (d) The breadth of each passenger carrying area is the distance between two vertical lines at the mid-length, excluding consoles, of the passenger carrying area when the boat is level as illustrated in Figures 7 and 8. For boats with round chines inside the passenger carrying area, the vertical line is where a transverse line 45 degrees to the horizontal is tangent to the arc of the chine, as illustrated in Figure 8.

NOTE:

See Appendix B for 33 CFR Subpart H, Figures 2–13.

FEDERAL LAW:

183.210 Reference areas.

- (a) The forward reference area of a boat is the forward most 2 feet of the top surface of the hull or deck, as illustrated in Figure 9.
- (b) The aft reference area of a boat is the aft most two feet of the top surface of the hull or deck, as illustrated in Figure 9.

NOTE:

See Appendix B for 33 CFR Subpart H, Figures 2–13.

FEDERAL LAW:

183.215 Reference depth.

Reference depth is the minimum distance between the uppermost surface of the submerged reference area of a boat and the surface of the water measured at the centerline of the boat, as illustrated in Figure 10. If there is no deck surface at the centerline of the boat from which a measurement can be made, the reference depth is the average of two depth measurements made on opposite sides of, and at an equal distance from, the centerline of the boat.

NOTE:

See Appendix B for 33 CFR Subpart H, Figures 2–13.

2.3 Subpart H — Flotation Requirements for Outboard Boats Rated for Engines of 2 Horsepower or Less

FEDERAL LAW:

- 183.305 Passenger carrying area.
- (a) For the purpose of this section, a boat is level when it is supported on its keel at the two points shown in Figure 2.
 - (b) As used in this subpart, the term “passenger carrying area” means each area in a boat in which persons can sit in a normal sitting position or stand while the boat is in operation. Passenger carrying areas are illustrated in Figures 3 through 8.
 - (c) The length of each passenger carrying area is the distance along the centerline of the boat between two vertical lines, one at the forward end and one at the aft end of the passenger carrying area, when the boat is level, as illustrated in Figures 3 and 4. For boats with a curved stem inside the passenger carrying area, the forward vertical line is where a line 45 degrees to the horizontal when the boat is level is tangent to the curve of the stem, as illustrated in Figure 5. For boats with cabins, the forward vertical line is where there is a minimum distance of two feet between the inside top of the cabin and the water line formed when the boat is swamped and loaded with weights under Sec. 183.320 as illustrated in Figure 6.
 - (d) The breadth of the passenger carrying area is the distance between two vertical lines at the mid-length, excluding consoles, of the passenger carrying area when the boat is level as illustrated in Figures 7 and 8. For boats with round chines inside the passenger carrying area, the vertical line is where a transverse line 45 degrees to the horizontal is tangent to the arc of the chine, as illustrated in Figure 7.

NOTE:

See Appendix B for 33 CFR Subpart H, Figures 2–13.

FEDERAL LAW:

- 183.310 Reference areas.
- (a) The forward reference area of a boat is the forward most 2 feet of the top surface of the hull or deck, as illustrated in Figure 9.
 - (b) The aft reference area of a boat is the aft most two feet of the top surface of the hull or deck, as illustrated in Figure 9.

NOTE:

See Appendix B for 33 CFR Subpart H, Figures 2–13.

FEDERAL LAW:**183.315 Reference depth.**

Reference depth is the minimum distance between the uppermost surface of the submerged reference area of a boat and the surface of the water measured at the centerline of the boat, as illustrated in Figure 10. If there is no deck surface at the centerline of the boat from which a measurement can be made, the reference depth is the average of two depth measurements made on opposite sides of, and at an equal distance from, the centerline of the boat.

NOTE:

See Appendix B for 33 CFR Subpart H, Figure 10

FIGURE 2.1 Length of Passenger Carrying Area — Location of Center of Gravity of Weights

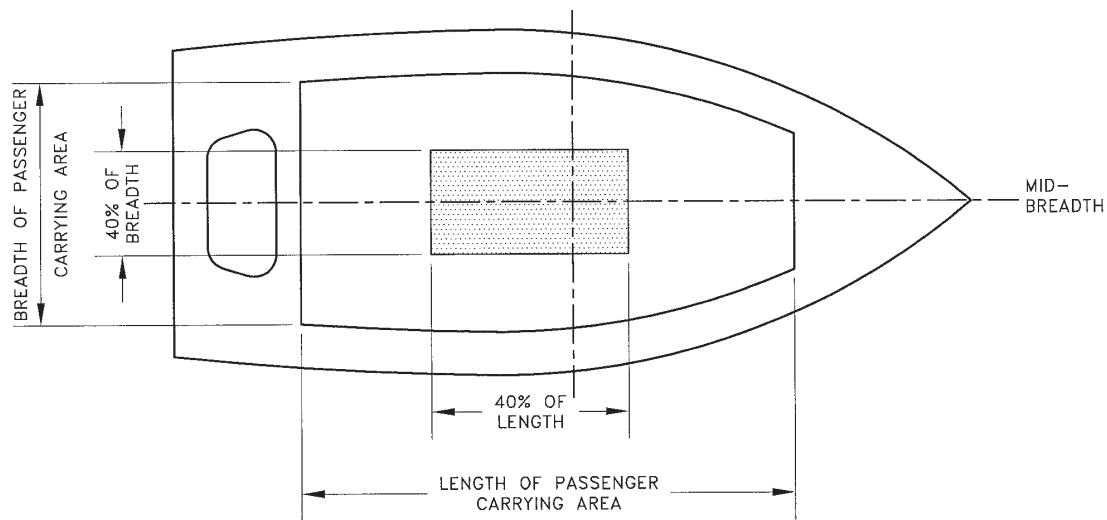

FIGURE 2.2 Length of Passenger Carrying Area — Boat with Deck

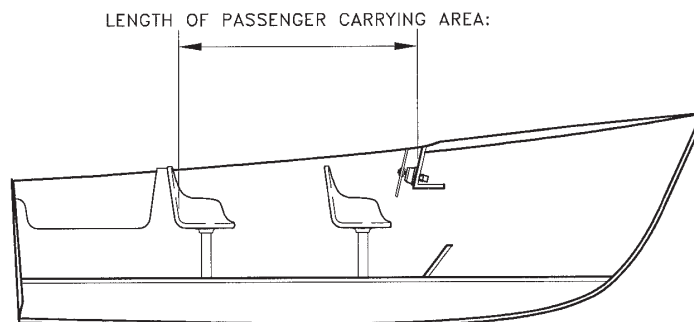

FIGURE 2.3 Length of Passenger Carrying Area — Boat with Center Console

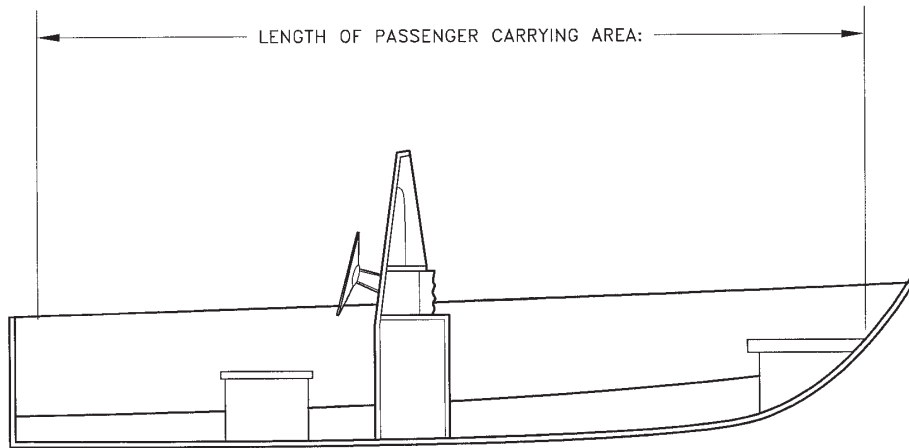

FIGURE 2.3 BOAT WITH CENTER CONSOLE

FIGURE 2.4 Length of Passenger Carrying Area — Open Boat with Curved Stem

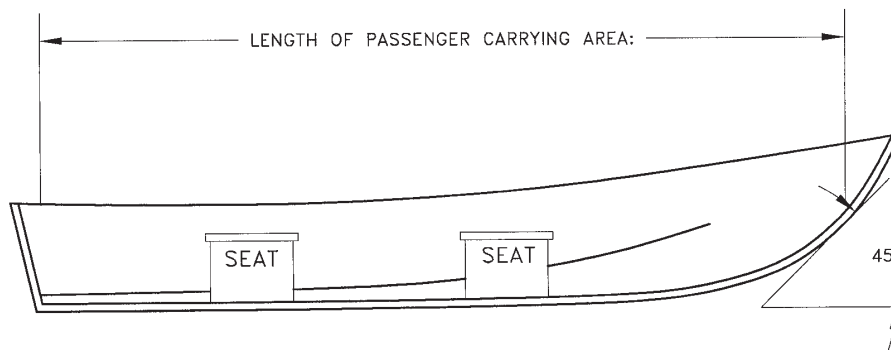
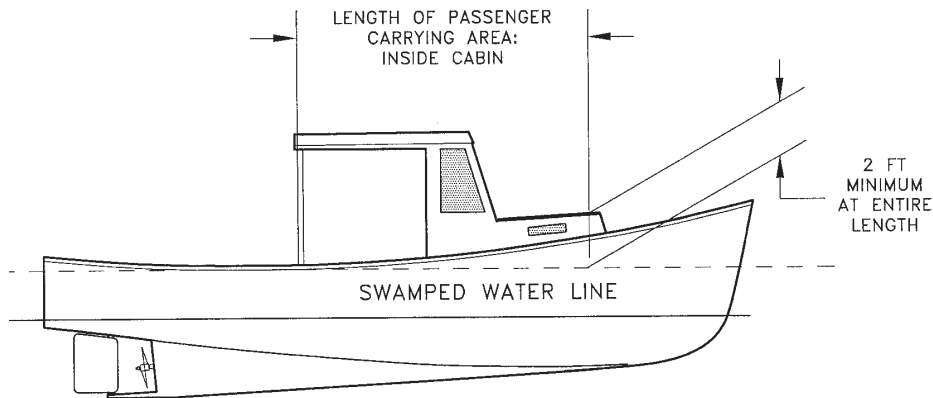

FIGURE 2.4 OPEN BOAT WITH CURVED STEM



FIGURE 2.5 Length of Passenger Carrying Area — Boat with Cabin

Loading Area: Forty percent of the length of the passenger carrying area and forty percent of the width of the passenger carrying area, centered in the passenger carrying area, and the position where the center of gravity of the test weights must be located. See figure 2.1.

Reference Area: [see 183.210 & 183.310] The forward-most two feet and the aft-most two feet of the top surface of the hull or deck, as shown in figure 2.6.

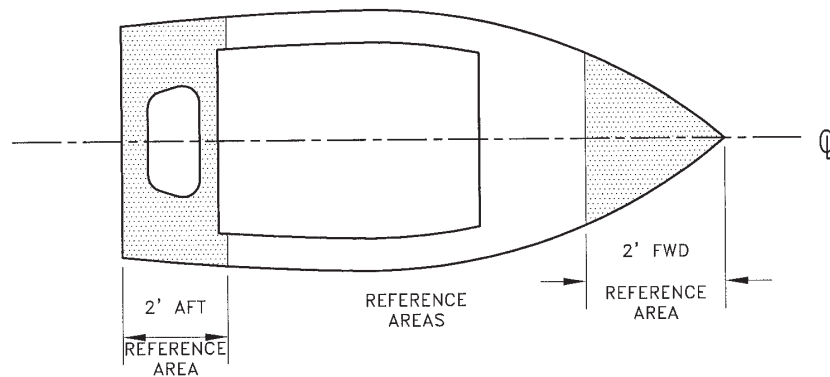
FIGURE 2.6 Reference Area

Reference Depth: [see 183.215 & 183.315] The minimum distance between the uppermost surface of the submerged reference area of a boat and the surface of the water measured at the centerline of the boat, as shown in figure 2.7.

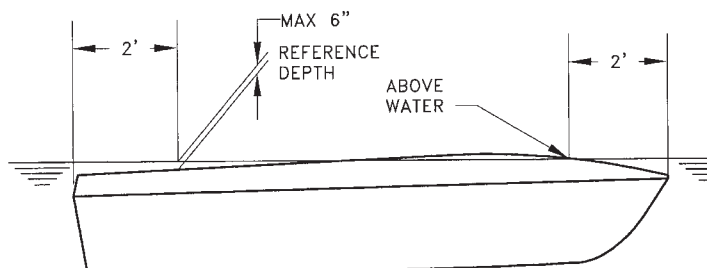
FIGURE 2.7 Reference Depth

Static Floating Position: The attitude in which a boat floats in calm, fresh water with fuel tanks filled to rated capacity, but with no person or items of portable equipment aboard. The boat should include all permanently installed factory supplied equipment and options such as, but not limited to the engine or engines, batteries, seats, engine oil, railings, fishing towers, etc. It should not include portable gear such as, but not limited to flags, searchlights, movable cushions, mattresses, portable fire extinguishers, lines, fenders, chairs, tables, anchors or live bait wells. See figures 2.8 and 2.9.

FIGURE 2.8 Static Floating Position

FIGURE 2.9 Location of Supports for Level Boat**NOTE:**

Point A is exactly at the waterline at the Bow; Point B, exactly at the intersection of the waterline and the centerline of the transom. Points C and D are at the waterline amidships, at either side. If the boat is mounted in chocks, this line should be horizontal.

FIGURE 2.10 Swamped Waterline

Swamped Waterline: A theoretical waterline above which dry weights will be used and below which submerged weights will be used, when calculating for the required flotation.

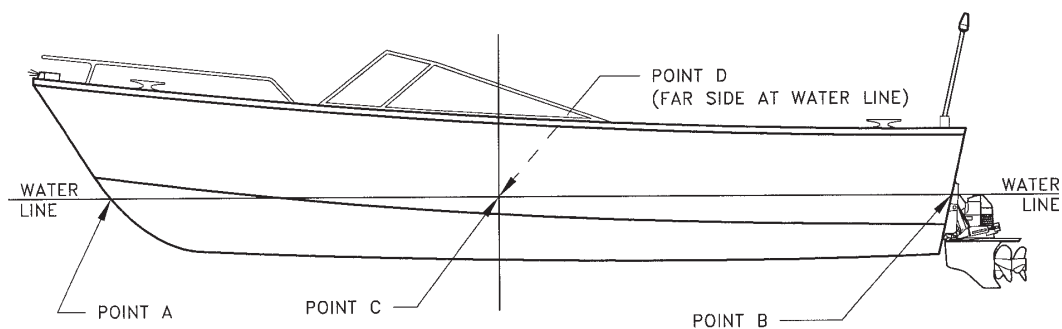
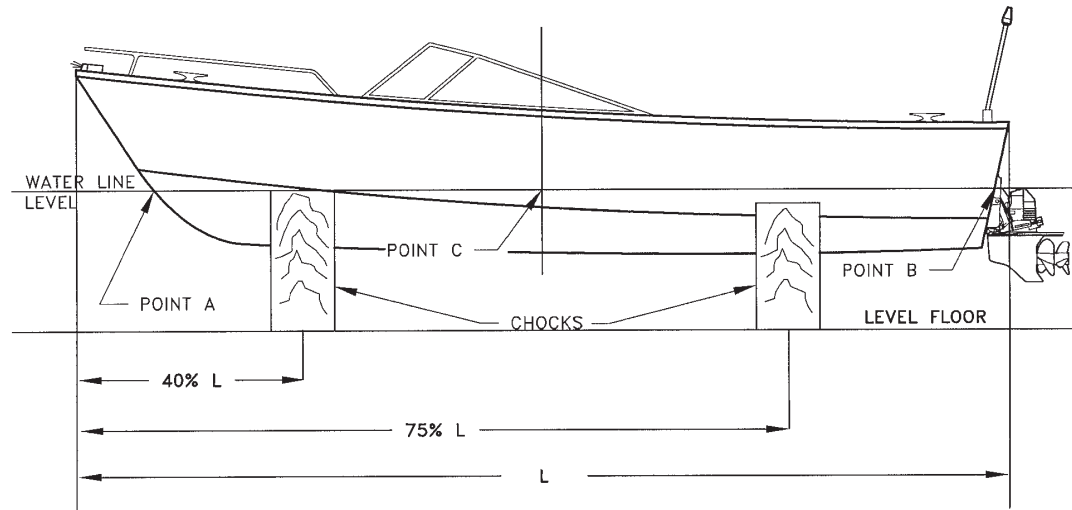
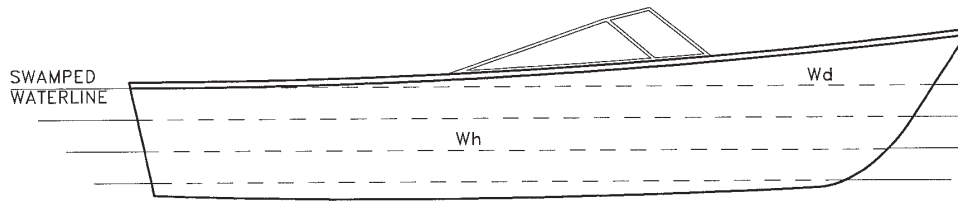
W_d = Dry weight of deck (all above swamped waterline including deck, windshield, hardware, factory accessories, etc.).

W_h = Dry weight of hull (all below swamped waterline).

Bilge: The area in the boat, below a height of 4 inches measured from the lowest point in the boat, where liquid can collect when the boat is in its static floating position, except engine rooms.

Connected: Allowing a flow of water in excess of one-quarter ounce per hour from the engine room bilge into any other compartment with a 12-inch head of water on the engine room side of the bulkhead.

Engine room bilge: The area in the engine room or a connected compartment below a height of 12 inches measured from the lowest point where liquid can collect in these compartments when the boat is in its static floating position.

Engine room: The compartment where a permanently installed gasoline or diesel engine is installed, including connected compartments.

Open to atmosphere: A compartment that has at least 15 square inches of open area directly exposed to the atmosphere for each cubic foot of net compartment volume.

Sealed compartment: An enclosure that can resist an exterior water level of 12 inches without seepage of more than one-quarter fluid ounce per hour.

3.0 PRECONDITIONING

Regardless of the flotation system, or the type of flotation materials used, the boat must be prepared and then pre-conditioned before beginning the test procedure. To prepare for preconditioning, the following must be done:

- the two largest air chambers, if used, must be vented at their high and low points.
- fuel tanks must be filled to their rated capacity with fuel and all external tank openings sealed.
- water tanks and holding tanks must be filled with water.
- provisions for flooded bait well, storage and iceboxes, and dry wells must be made.
- all compartments that may entrap air must be thoroughly vented.
- seats, seat cushions, and upholstery items must be vented so that they cannot entrap air.

Following preparation as outlined above, the boat must be pre-conditioned. Preconditioning consists of swamping the boat for 18 hours. Weights to simulate the outboard motor, controls and battery where applicable (outboard boats), the persons capacity, and the dead weight in accordance with the type of flotation system must be in place. At the end of the pre-conditioning, testing may begin. The type of test(s) to be performed will be determined by the type of flotation system used, i.e.: Basic, Level or Modified Level.

3.1 Subpart F — Inboard Boats, Inboard/Outdrive (Sterndrive) and Airboats

Inboard boats, Sterndrives and Airboats have to be submerged in fresh water for at least 18 hours. See 183.105.

3.2 Subpart G — Outboard Boats Rated for More Than 2 Horsepower

FEDERAL LAW:

183.220 Preconditioning for tests.

A boat must meet the following conditions for at least 18 hours before the tests required by Secs. 183.225, 183.230, and 183.235

- (a) Manufacturer supplied permanent appurtenances such as windshields and convertible tops must be installed on the boat.
- (b) The boat must be loaded with a quantity of weight that, when submerged, is equal to the sum of the following:
 - (1) The sum of 50 percent of the first 550 pounds of the persons capacity marked on the boat and 12-1/2 percent of the remainder of the persons capacity.
 - (2) Twenty-five percent of the result of the following calculation, but not less than zero: The maximum weight capacity marked on the boat; less the weight shown in Column 6 of Table 4 for maximum horsepower marked on the boat; less the persons capacity marked on the boat.
- (c) The weights required by paragraph (b) of this section must be placed in the boat so that the center of gravity of each amount of weight required by paragraphs (b) (1) and (b) (2) of this section is within the shaded area illustrated in Figure 11. The location and dimensions of the shaded area are as follows:
 - (1) The shaded area is centered at the mid-length of the passenger carrying area and at the mid-breadth of the boat;
 - (2) The length of the shaded area, measured along the centerline of the boat, is equal to 40 percent of the length of the passenger carrying area of the boat; and
 - (3) The breadth of the shaded area, measured at the midlength of the passenger carrying area, is equal to 40 percent of the breadth of the passenger carrying area of the boat.

continues on page 18 . . .

FEDERAL LAW: *Sec. 183.220 continued . . .*

- (d) Weight must be placed in the normal operating position of the motor and controls and the battery in lieu of this equipment. The required quantity of weight used for this purpose depends upon the maximum rated horsepower of the boat being tested and is specified in Columns 2 and 4 of Table 4 for the swamped weight of the motor and controls and for the submerged weight of the battery, respectively.
- (e) Permanent fuel tanks must be filled with fuel and each external opening into the fuel tank must be sealed.
- (f) The boat must be keel down in the water.
- (g) The boat must be swamped, allowing water to flow between the inside and outside of the boat, either over the sides, through a hull opening, or both. Entrapped air in the flooded portion of the boat must be eliminated.
- (h) Water must flood the two largest air chambers and all air chambers integral with the hull.

NOTE:

See Appendix A for Table 4. See Appendix B for 33 CFR Subpart H, Figures 2–13.

3.3 Subpart H — Flotation Requirements for Outboard Boats Rated for Engines of 2 Horsepower or Less

FEDERAL LAW:

183.320 Preconditioning for tests.

A boat must meet the following conditions for at least 18 hours before the tests required by Secs. 183.325, 183.330, and 183.335:

- (a) Manufacturer supplied permanent appurtenances such as windshields, and convertible tops must be installed on the boat.
- (b) The boat must be loaded with a quantity of weight that, when submerged, is equal to the sum of the following:
 - (1) Two-fifteenths of the persons capacity marked on the boat.
 - (2) Twenty-five percent of the result of the following calculation, but not less than zero: the maximum weight capacity marked on the boat; less the weight shown in column 6 of Table 4 for the maximum horsepower marked on the boat; less the persons capacity marked on the boat.
- (c) The weights required by paragraph (b) of this section are placed in the boat so that the center of gravity of each amount of weight required by paragraphs (b)(1) and (b)(2) of this section is within the shaded area illustrated in Figure 11. The location and dimensions of the shaded area are as follows:
 - (1) The shaded area is centered at the mid-length of the passenger carrying area and at the mid-breadth of the boat;
 - (2) The length of the shaded area, measured along the centerline of the boat, is equal to 40 percent of the length of the passenger carrying area of the boat; and
 - (3) The breadth of the shaded area, measured at the mid-length of the passenger carrying area, is equal to 40 percent of the breadth of the passenger carrying area of the boat.
- (d) Weight must be placed in the normal operating position of the motor and controls in lieu of this equipment. The quantity of weight used for this purpose depends upon the maximum rated horsepower of the boat being tested and is specified in Column 2 of Table 4 for the swamped weight of the motor and controls.
- (e) Permanent fuel tanks must be filled with fuel and each external opening into the fuel tank must be sealed.
- (f) The boat must be keel down in the water.
- (g) The boat must be swamped, allowing water to flow between the inside and the outside of the boat, either over the sides, through a hull opening, or both. Entrapped air in the flooded portion of the boat must be eliminated.

NOTE:

See Appendix A for Table 4. See Appendix B for 33 CFR Subpart H, Figures 2–13.

4.0 Basic Flotation

FEDERAL LAW:

- 183.105 Quantity of flotation required.
- (a) Each boat must have enough flotation to keep any portion of the boat above the surface of the water when the boat has been submerged in calm, fresh water for at least 18 hours and loaded with:
- (1) A weight that, when submerged, equals two-fifteenths of the persons capacity marked on the boat;
 - (2) A weight that, when submerged, equals 25 percent of the dead weight; and
 - (3) A weight in pounds that, when submerged, equals 62.4 times the volume in cubic feet of the two largest air chambers, if air chambers are used for flotation.
- (b) For the purpose of this section, "dead weight" means the maximum weight capacity marked on the boat minus the persons capacity marked on the boat.

In addition to the quantity of flotation required, the regulation then deals with flotation material tests and specifications. See Section 7.0. The regulation does not deal with the methods to calculate how much foam is necessary, and where to install it. That is the purpose of this Guideline.

Basically, our method is to calculate the flotation material needed to support the following components when the boat is submerged:

- a. the submerged boat;
- b. the submerged propulsion equipment;
- c. a portion of the passenger load;

The total flotation material needed is the sum of the three components above.

Boats requiring Basic Flotation are fitted with buoyant materials or acceptable flotation systems in at least the minimum quantity as determined below. Void compartments or air chambers integral with the hull shall not be included as part of the required flotation materials.

If non-integral air chambers are used for flotation, the requirements for Basic Flotation shall be met excluding the two largest air chambers.

Calculations: To determine the total flotation material needed to support the boat, we will separately determine the flotation needed to support the boat (hull and deck), the propulsion machinery and the passengers (persons capacity).

Formula: $F = F_b + F_p + F_c$

Where: F = Total flotation

F_b = Flotation for the submerged boat

F_p = Flotation for the submerged propulsion machinery

F_c = Flotation for the passengers (persons capacity)

NOTE:

In Basic Flotation we are considering the submerged weights since only a small portion of the boat will be out of the water.

Step 1: Determine the flotation needed to support the submerged boat (F_b).

Formula: $F_b = ([W_h \times K] + [W_d \times K] + .69W_e) \div B$

Where: F_b = flotation needed
 W_h = dry weight of hull
 W_d = dry weight of deck and superstructure
 W_e = dry weight of factory installed equipment, hardware and accessories
 K = conversion factor for material used. See Table 4.1 below
 B = buoyancy of one cubic foot of flotation material expressed in pounds.

NOTE:

*If air is used, B will simply be 62.4 pounds (the weight of fresh water displaced by 1 cu ft). If foam is used, B will equal the weight of 1 cu. ft. of fresh water, **minus** the weight of one cu. ft. of the foam used, **minus** the amount of water absorbed by this foam when submerged for 18 hours.*

Of course the submerged weight of the hull is the result of adding the weights of each component multiplied by each component factor listed in Table 4.1 below e.g.: fiberglass x 0.33, fir plywood x -0.81, aluminum tanks x 0.63, etc. There is no factor K as a whole; K is a value (multiplier) used to derive the submerged weight of each component. See example below.

Step 2: Determine the flotation material needed to support the submerged propulsion equipment (F_p).

Formula: $F_p = G \div B$

Where: G = 75% of the installed weight of the engine, drive and battery (inboard), or the engine, outdrive and battery (sterndrive) — in pounds to the nearest whole number;
 B = Buoyancy of 1 cu.ft. of flotation material used in pounds.

Step 3: Determine the flotation material needed to support the persons capacity (F_c).

Formula: $F_c = .25 (C) \div B$

Where: C = Maximum weight capacity.
 B = Buoyancy of 1 cu.ft. of flotation material used in pounds.

NOTE:

The regulation calls for 2/15 (0.133) of the persons capacity. This Guideline uses 0.25, resulting in slightly more flotation in the boat. This safety factor will help ensure that the boat meets the minimum requirement in the event of minor weight changes during construction.

Step 4: Determine the total flotation material needed (F) to support the boat. This is the sum of steps 1, 2, and 3 above.

Formula: $F = F_b + F_p + F_c$

Table 4.1 Factors (K) for Converting Various Boat Materials from Dry to Submerged Weight

Material	Specific Gravity	Factor (K)	Pounds/Cubic Foot
Lead	11.38	0.91	710
Copper	8.91	0.89	556
Monel Metal	8.91	0.89	556
Bronze	8.88	0.89	554
Nickel	8.61	0.88	537
Brass	8.56	0.88	534
Stainless Steel	8.00	0.88	500
Steel	7.85	0.88	490
Cast Iron	7.08	0.86	442
Zinc-Cast Alloy	6.63	0.85	414
Aluminum	2.73	0.63	170
Glass	2.60	0.62	162
Ferro-Cement	2.40	0.58	150
Rubber	1.51	0.34	94
Fiberglass (Laminate)	1.50	0.33	94
Kevlar	1.30	0.24	81
Plexiglass-Lucite	1.20	0.17	75
Linoleum*	1.17	0.15	72
A.B.S.	1.12	0.11	70
Teak	0.99	-0.01	62
Oak-White	0.85	-0.18	53
Oil-Diesel	0.85	-0.18	53
Gasoline	0.73	-0.37	45
Oak	0.63	-0.56	39
Blandex	0.58	-0.70	36
Mahogany — Philippine	0.58	-0.72	36
Mahogany — Honduras	0.56	-0.78	35
Ash	0.56	-0.78	35
Yellow Pine	0.55	-0.81	34
Fir Plywood	0.55	-0.81	34
Mahogany Plywood	0.54	-0.83	34
Royalex	0.50	-0.95	31
Mahogany — African	0.51	-0.96	32
Fir	0.51	-0.96	32
Cedar — Port Orford	0.48	-1.08	30
Pine — White	0.42	-1.38	26
Cedar — White	0.33	-1.95	21
Cork	0.24	-3.17	15
Balsa — End Grain	0.16	-5.24	10

*1.5 pounds/square foot for 1/4 inch thick linoleum.

The factors in Table 4.1 are calculated using the following formula:

$$\text{Factor} = \frac{\text{Specific gravity}-1}{\text{Specific gravity}}$$

This formula may be used to obtain the factor for materials not listed in Table 4.1.

NOTE:

The specific gravity is the ratio of the density of a substance to the density of fresh water at 39° F.

Weight of water – fresh, at 39° F = 62.4 pounds/cubic foot

Specific gravity of water – fresh, at 39° F = 1.0

4.1 Example of Basic Flotation Calculations

Assume an Inboard/Outdrive (Sterndrive) runabout with the following specifications:

Length Overall	18'-6"
Beam	7'-3"
Propulsion	210 HP Inboard/Outdrive
Machinery weights	1,075 lb.
Maximum weight capacity	1,400 lb.
Maximum persons capacity	1,100 lb. or 8 persons
Dry hull weight	800 lb. (fiberglass 650 lb. + plywood 150 lb.)
Dry deck weight	300 lb. (fiberglass 245 lb. + plywood 55 lb.)
Deck hardware	228 lb. (Mostly aluminum)
Hull hardware	110 lb. (Aluminum 80 lb. + stainless steel 30 lb.)
Total weight	2,513 lb.

From section 1.0 we determine that this boat will have to comply with the Basic Flotation requirement. This means we need only float the boat with equipment and a certain amount of the passenger load.

In Basic Flotation we consider the entire boat to be submerged. There is no swamped water line, and consequently all the components will be affected by the conversion factors in Table 4.1. We will now run through the calculations to determine how much flotation will be required. We will use Table 4.1 for the weight conversion factors of materials.

Step 1: Flotation needed to support the submerged boat.

Formula: $F_b = ([W_h \times K_1] + [W_d \times K_2] + .69W_e) \div B$

Let's identify the components and determine their weights when submerged:

	Part Description	Weight		Factor (K) Table 4.1		Submerged Weight
W_h	Weight of fiberglass hull	650	x	0.33	=	214.5
	+					
	Weight of hull fir plywood	150	x	-0.81	=	-121.5
	+					
	Weight of hull aluminum hardware	80	x	0.63	=	50.4
	+					
	Weight of hull steel hardware	30	x	0.88	=	26.4
W_h = Submerged weight of hull						169.8 lb.
W_d	Weight of fiberglass deck	245	x	0.33	=	80.8
	+					
	Weight of fir plywood on deck	55	x	-0.81	=	-44.5
W_d = Submerged weight of deck						36.3 lb.
W_e	Weight of factory installed equipment	228	x	0.63	=	143.6
W_e = Submerged weight of factory installed equipment, etc.						143.6 lb.

B will be calculated as follows (assuming use of Polyurethane foam of 2.0 lb. density)

$B = 62.4 - 2.0 = 60.4$; then allow for 5% moisture absorption ($2.0 \times 0.05 = 0.1$)

$B = 60.3$ lb.

Substituting in the formula:

Step 1: Flotation needed to support the swamped boat.

Formula: $F_b = ([169.8] + [36.3] + [143.6]) \div 60.3$

$F_b = 5.8$ cubic feet of foam

Step 2: Flotation needed to support the submerged propulsion equipment.

Formula: $F_p = G \div B$

$G = 75\% \text{ of } 1075 \text{ lb. (engine, outdrive and battery)} = 806.2$

$B = 60.3 \text{ lb.}$

$F_p = 806.2 \div 60.3$

 $F_p = 13.4 \text{ cubic feet of foam}$

Step 3: Flotation needed to support the passengers.

Formula: $F_c = 0.25 (C) \div B$

$F_c = 0.25 \times 1400 \div 60.3$

 $F_c = 5.8 \text{ cubic feet of foam}$

Step 4: Total flotation needed for Basic Flotation.

Formula: $F = F_b + F_p + F_c$

$F = 5.8 + 13.4 + 5.8 = 25$

 $F = 25 \text{ cubic feet of foam}$

NOTE:

The Basic Flotation requirements do not address where the foam is located in the boat.

4.2 Summary of Basic Flotation Performance Requirements

The manufacturer must be sure that the boat will float, in any position, when loaded according to the regulation. Figuring the calculations alone may not satisfy the regulation; consequently, the boat should be pre-conditioned, loaded with the weights prescribed, and then swamped.

5.0 Level Flotation

FEDERAL LAW:

183.202 Flotation and certification requirements.

Each boat to which this subpart applies must be manufactured, constructed, or assembled to pass the stability and flotation tests prescribed in Secs. 183.225 (a), 183.230 (a), and 183.235 (a).

The regulation is complex and difficult to read. The objective of this Guideline is to help the manufacturer calculate first how much foam will be needed to support each of the components (the boat, the machinery, and a portion of the passengers) and then indicate where that flotation material must be installed to pass the required tests. The methods were developed over many years, and the Guideline uses numbers and factors that result in flotation that meets or exceeds the requirements of the regulation. Following these steps carefully will result in successfully floating the boat in the manner prescribed. Some experimentation in testing may be necessary.

Boats requiring Level Flotation shall be fitted with buoyant materials or acceptable flotation systems in at least the minimum quantity as determined below. Void compartments or air chambers that are integral with the hull shall not be included as part of the flotation required.

Flotation material located at the sides, as far aft and as high as possible, will help make boats with machinery located aft float level when swamped. Some boats may require the keel area inside the boat to be void of flotation material so that the space can flood from either end to provide proper balance in the swamped condition.

Integral air chambers cannot be counted toward meeting the Level Flotation requirements. If non-integral air chambers are used for flotation, the Level Flotation requirements must be met excluding the two largest air chambers.

Basically, our method is to calculate the flotation material needed to support the following components when the boat is swamped:

- a. the swamped boat;
- b. the swamped outboard engine and submerged battery;
- c. a portion of the persons capacity;

The total flotation material needed is the sum of a + b + c. The boat must float level and pass a stability test.

Calculations: To determine the total flotation material needed to support the boat and keep it level, we use the following formula:

$$F = F_b + F_p + F_c$$

Where:

- F = Total flotation material
- F_b = Flotation for the swamped boat
- F_p = Flotation for the submerged propulsion machinery
- F_c = Flotation for the passengers (a portion of)

The idea here is that the boat, without its propulsion equipment and passengers, will have to be swamped and supported with a certain amount of flotation material distributed symmetrically so as to keep it relatively level. When you add the propulsion systems, the boat will be disproportionately heavier aft and consequently the flotation material needed to support the engine and drive will have to be located far aft to counter this unbalance. Finally, through experience we know that the flotation material needed to support the portion of the passengers (persons capacity) must be located way out on the boat's sides and as high as possible. This is so that the boat may pass the stability test's maximum permitted heel angle.

Symmetrical location criteria for the flotation system are established for each of the three quantities above. For example, one cubic foot of flotation material three feet forward of the boat's balance point (when out of the water) can be balanced by three cubic feet of flotation material one foot aft of the boat's balance point. The symmetry may, and should, be varied to account for equipment (such as batteries) if located off-center.

Calculations

Step 1: Determine the flotation needed to support the swamped boat (F_b).

Formula: $F_b = [(W_h \times K) + W_d] \div B$

Where: W_h = dry weight of the hull
(Everything below the swamped waterline)

W_d = dry weight of deck (everything above the swamped waterline,
including factory supplied windshield, hardware and accessories)

K = conversion factors for materials used, from Table 4.1

B = buoyancy of flotation materials used, in pounds per cubic foot

NOTE:

*If air is used, B will simply be 62.4 pounds (the weight of fresh water displaced by 1 cu ft). If foam is used, B will equal the weight of 1 cu. ft. of fresh water, **minus** the weight of one cu. ft. of the foam used, **minus** the amount of water absorbed by this foam when submerged for 18 hours.*

Discussion:

Since the hull will be submerged (as in section 4.0), W_h is the sum of the weight of the different components of the hull (fiberglass, wood, steel, etc.) multiplied by the conversion factor in Table 4.1. W_d , however, is the sum of the dry weights of the deck components since the deck will remain above water. Buoyancy of the flotation material shall include allowances for some water absorption.

This flotation material shall be located symmetrically about the balance point of the boat.

Figures 5.1, 5.2, and 5.3 following show the principle of symmetry about the balance point of the boat. Look carefully at how the boat's balance point (longitudinally) may be found on the factory floor by balancing the boat over a piece of pipe. Use the information contained here to save time in the test tank. You may distribute the flotation material needed for each step prior to testing.

FIGURE 5.1 Placement of Flotation Material

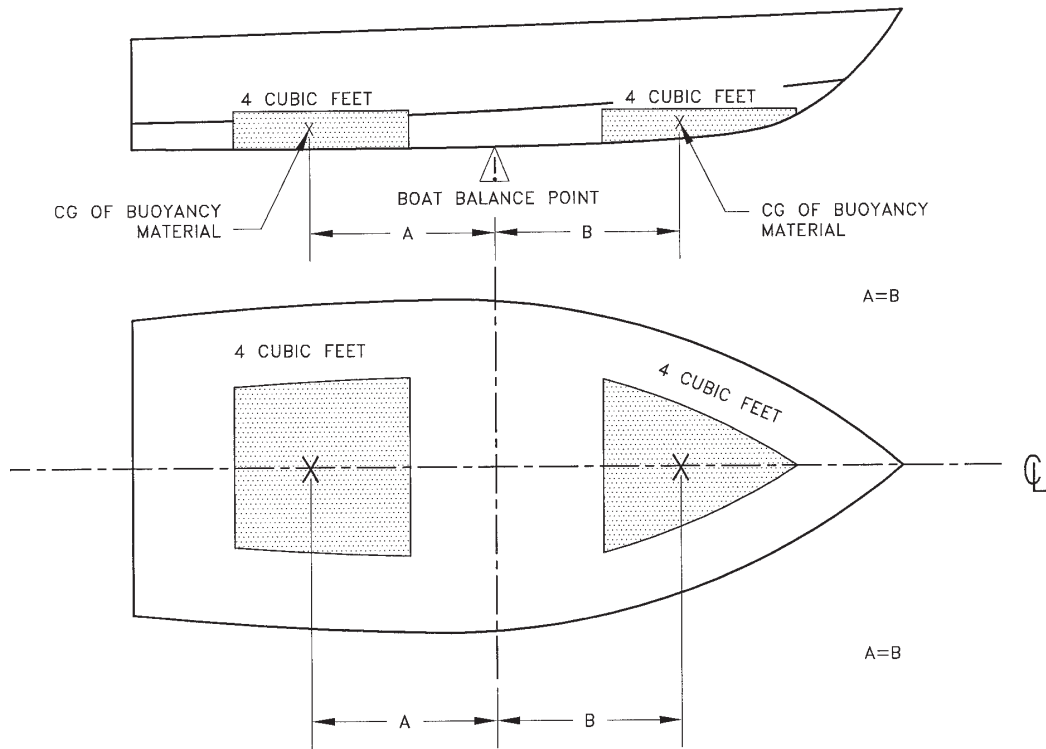

FIGURE 5.2 Placement of Flotation Material

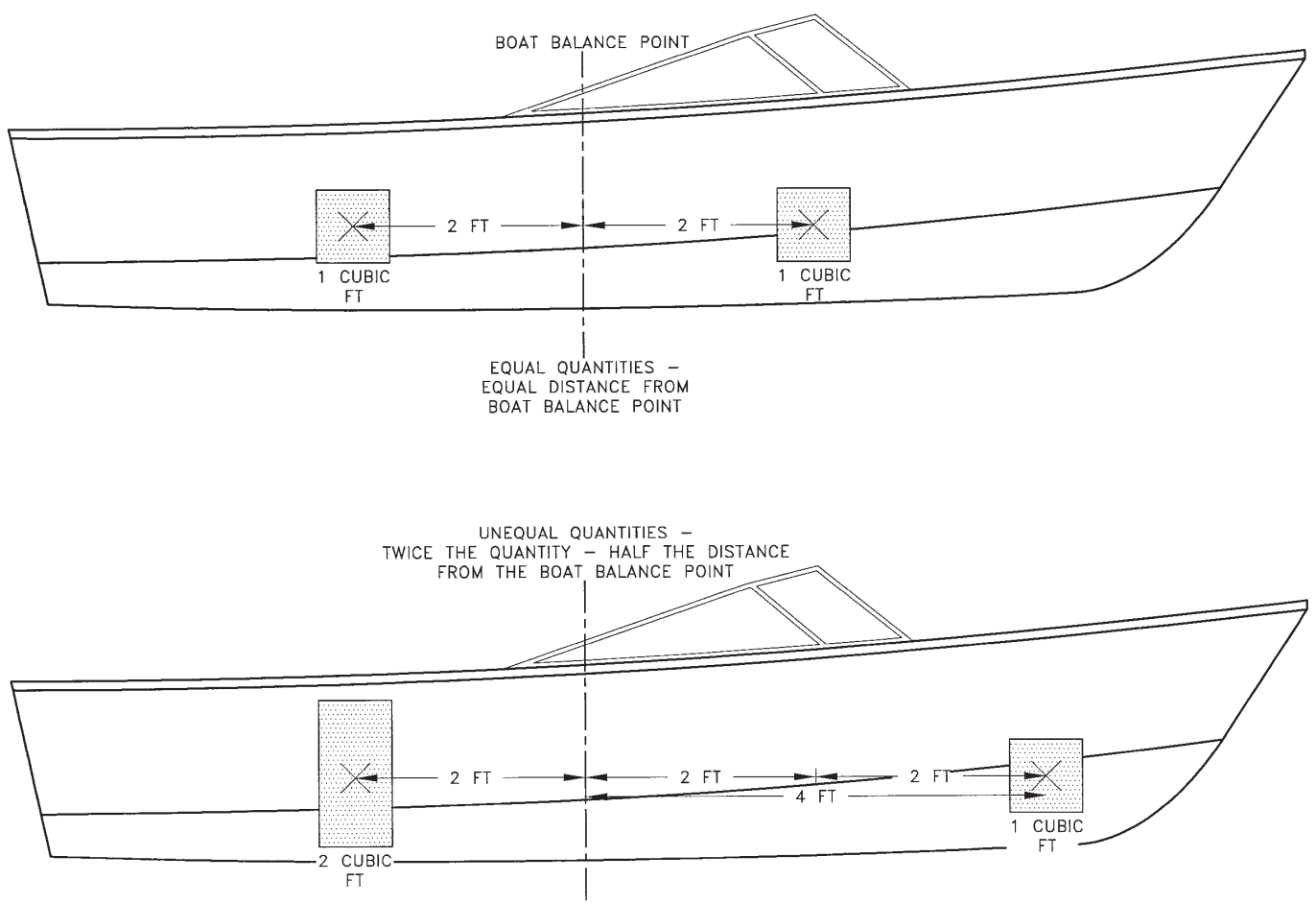
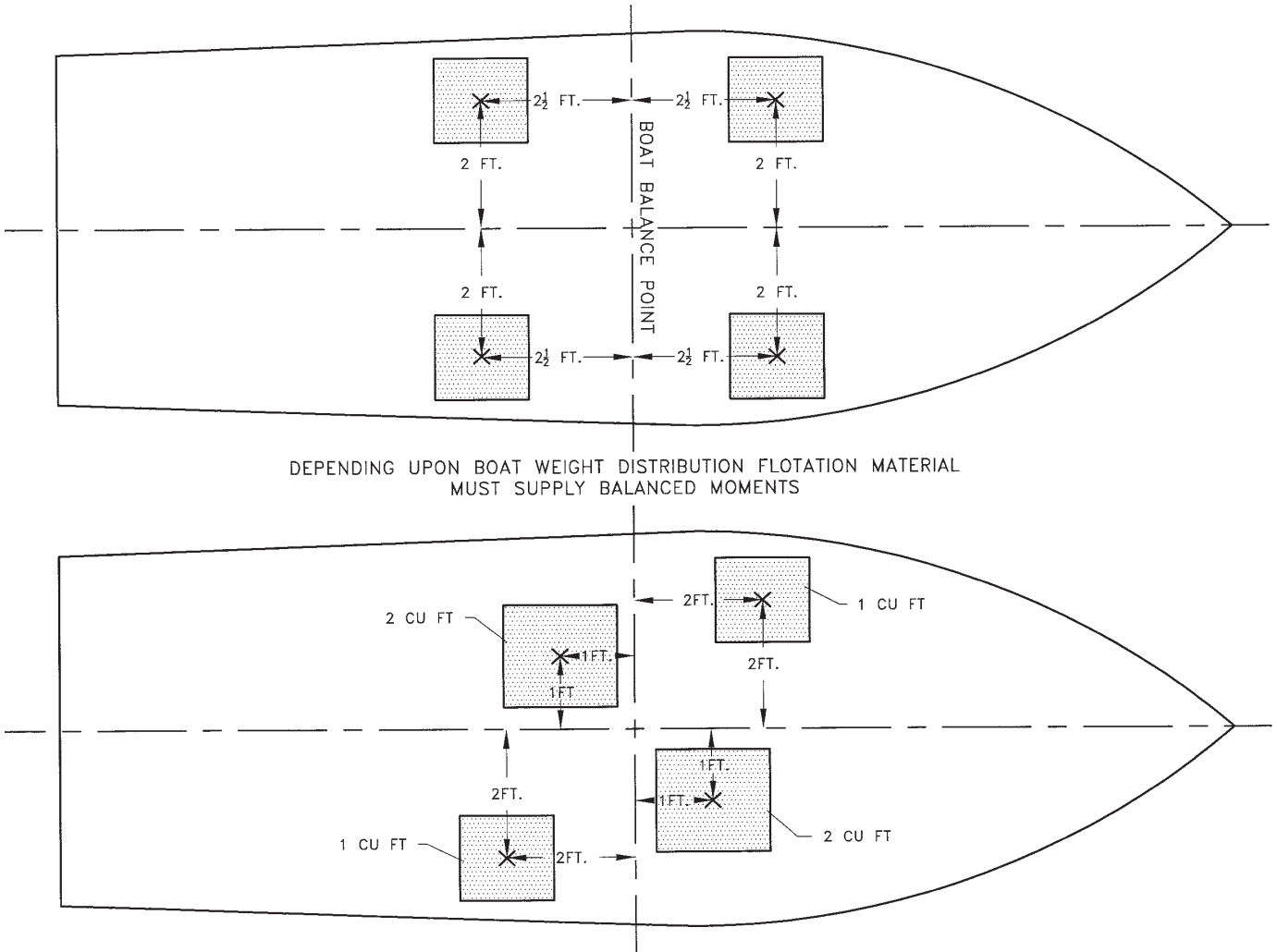

FIGURE 5.2 PLACEMENT OF FLOTATION MATERIAL



FIGURE 5.3 Placement of Flotation Material



Step 2. Determine the flotation material needed to support the swamped propulsion equipment (F_p).

Formula: $F_p = S \div B$

Where: S = The swamped weight of the maximum horsepower capacity engine for which the boat is rated on the capacity label, plus the submerged weight of the battery. All are found in Table 4, columns 2 and 4. (See Appendix A.)
B = The buoyancy of the flotation material in pounds per cubic foot.

NOTE:

The Coast Guard has been given authority to randomly check boats for compliance with the flotation requirements. When this check is conducted, simulated outboard engine weights are used rather than an actual outboard engine. The weight used during this check is obtained from the outboard engine weight table included in Subpart H (Flotation) of the CFR (see Table 4). Due to changing technology, outboard engines heavier than those listed in Table 4 are available. This is particularly true in the case of 4 stroke engines. The reader is encouraged to refer to ABYC Standard S-30, Outboard Engines and Related Equipment Weights, for the latest outboard engine weight table.

Distribute this material symmetrically within 36 inches (30 inches for boats of less than 15 feet in length) of the outside of the transom top at the motor-mounting area or around the propulsion system if engines are not stern mounted.

In small boats, sometimes it is difficult to pack the flotation material in the compartments prescribed here. Use the space on the deck aft, but stay within the 36-inch area (30 for boats under 15 ft.).

FIGURE 5.4 Flotation Material for Propulsion System

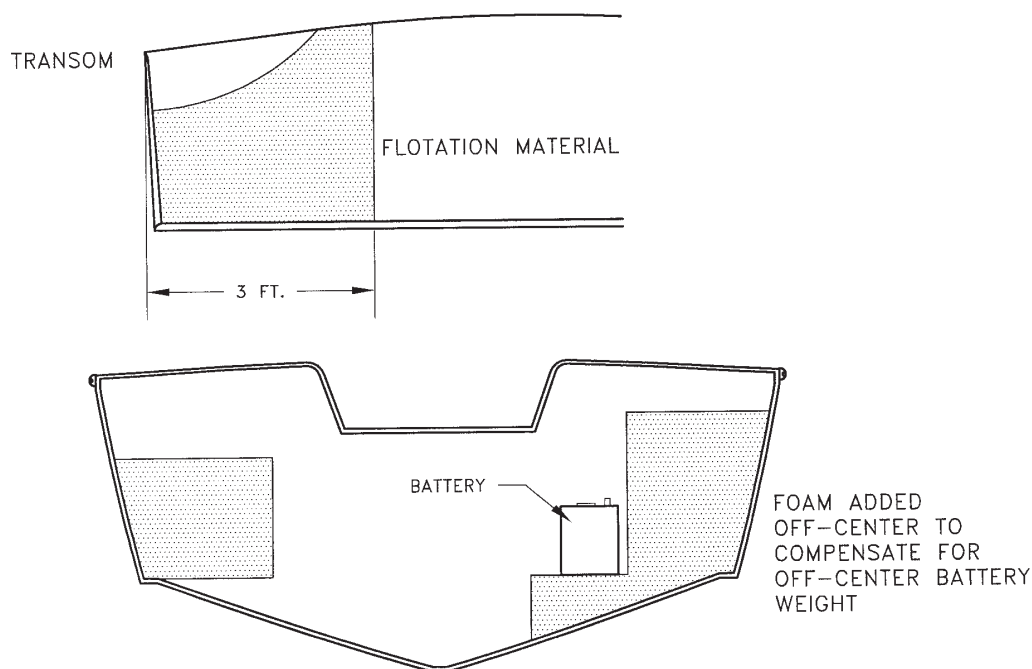

Step 3: Determine the flotation needed to support the persons capacity (F_c)**Formula:**

$$F_c = \frac{.5(\text{first 550 lb. of persons capacity}) + .125(\text{remaining persons capacity}) + .25(C_{lev} - \text{persons capacity})}{B}$$

Where: C_{lev} = C (maximum weight capacity) minus weight in column 6, Table 4 for the maximum horsepower rating of the boat. (See Appendix A.)
 B = Buoyancy of flotation material in pounds per cubic foot.

Discussion:

This may look confusing. The reason for the regulation requiring the manufacturer to support only part of the passenger load is that this weight (in testing) is added dry, and the assumption is that the actual passengers will be partially submerged thus enhancing buoyancy. The last entry $[.25(C_{lev} - \text{persons capacity})]$ is the gear weight allowed or the difference between the values for maximum weight capacity and persons capacity exhibited on the boat's capacity label.

NOTES:

1. If C_{lev} is negative, use zero.
2. Use the persons capacity and maximum weight capacity that will be shown on the boat's capacity plate.

In order to achieve a level attitude when conducting the flotation tests, it will be necessary to distribute the flotation material symmetrically on both sides and fore and aft of the passenger carrying area mid-point at the hull sides as close to the sheer line as possible. It should be located outside a vertical plane that is parallel to the keel, and within 6 inches of the hull sides at the widest point on the floor line. This will assure the necessary righting moments to pass the stability test. The flotation material must be as far out and as high in the gunwales as possible.

Step 4: Determine the total flotation material needed (F)

Formula: $F = F_b + F_p + F_c$

The total flotation material required is the sum of the results in steps 1, 2, and 3 above.

FIGURE 5.5 Flotation Material Placement

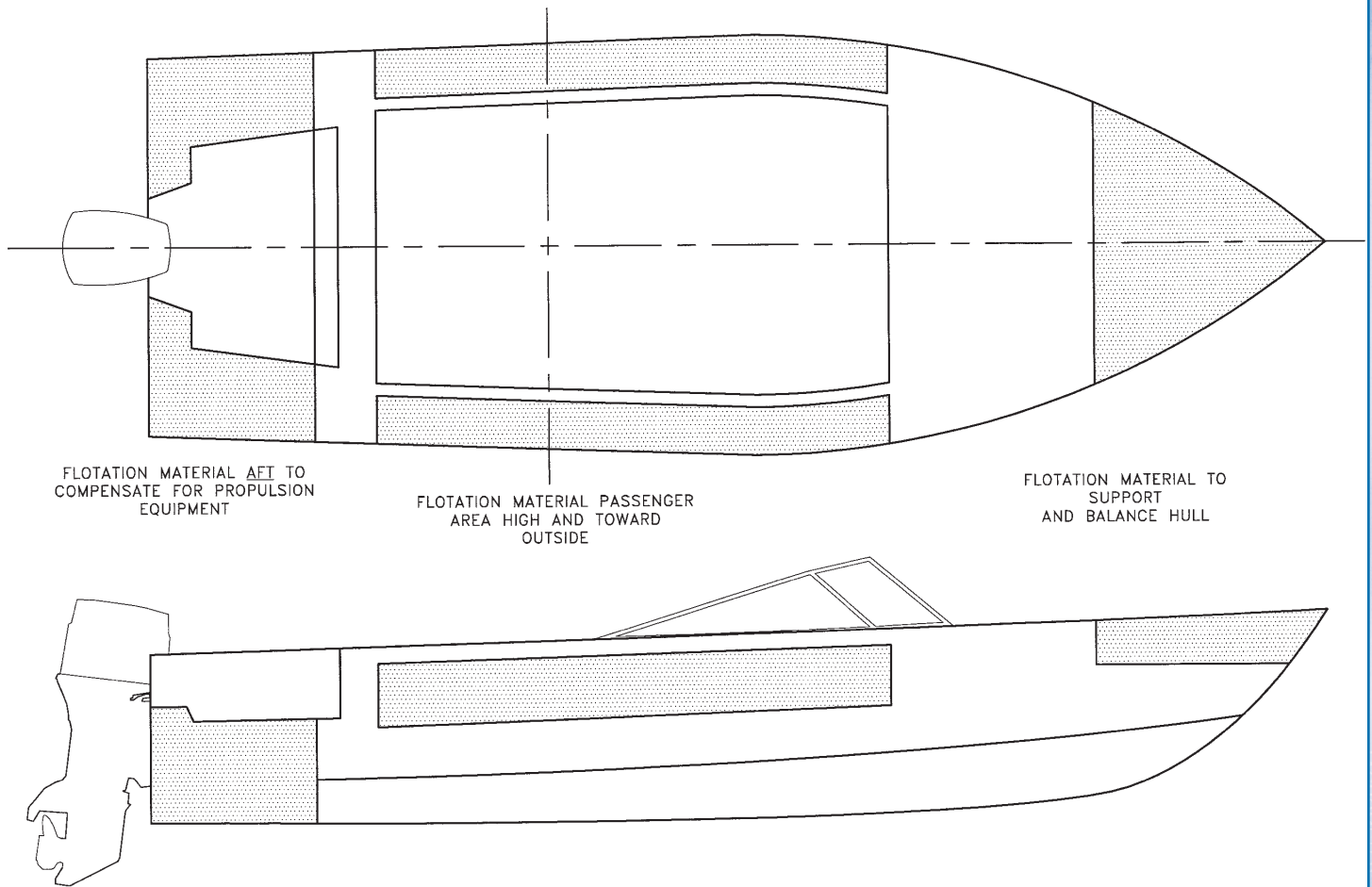
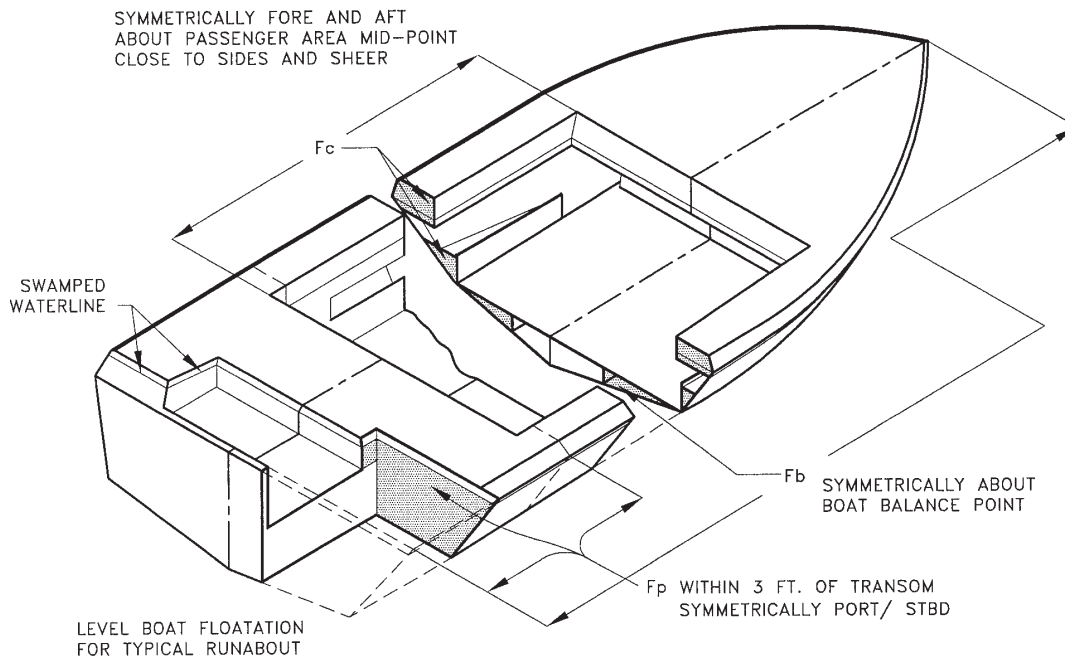
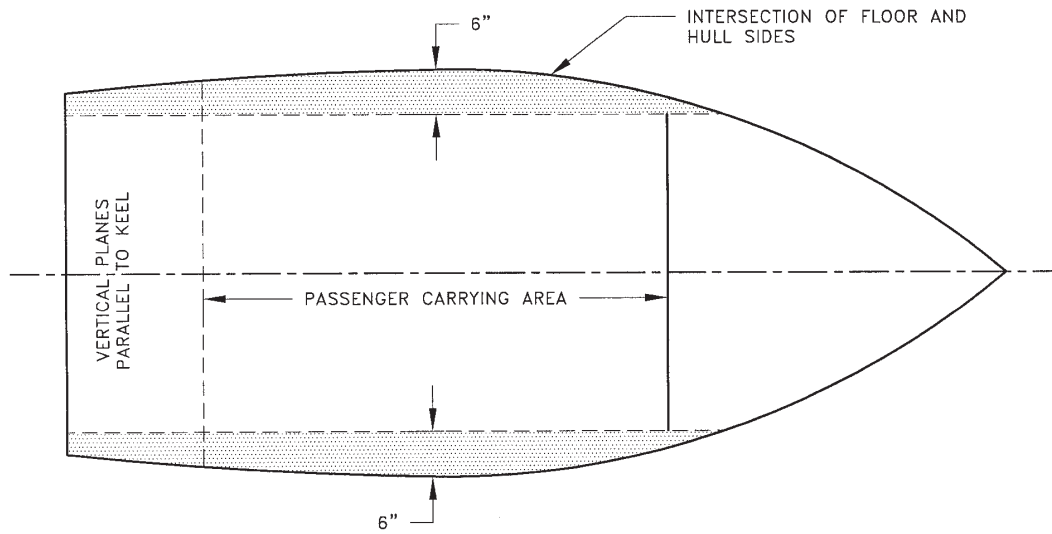
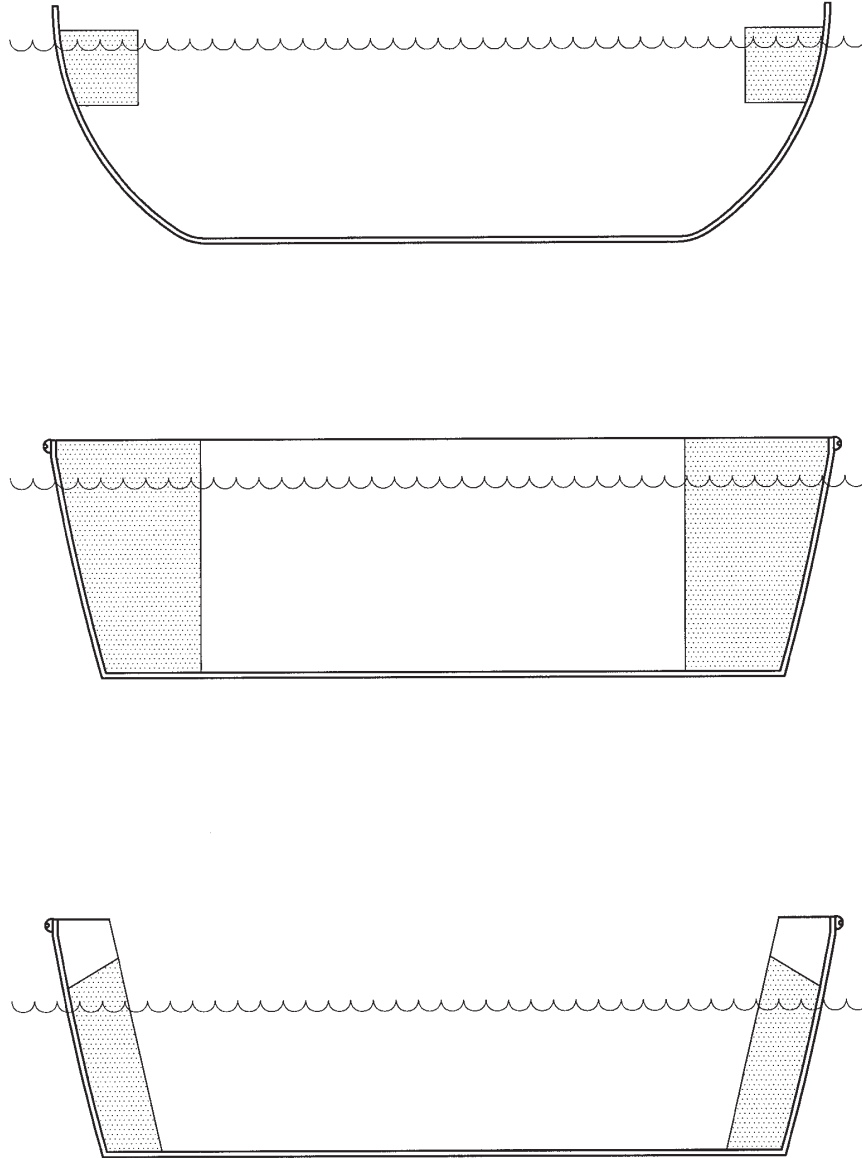

FIGURE 5.6 Flotation Material Placement



- F_b = THE FLOTATION MATERIAL NEEDED TO SUPPORT THE SWAMPED BOAT
- F_p = THE FLOTATION MATERIAL NEEDED TO SUPPORT THE PROPULSION EQUIPMENT
- F_c = THE FLOTATION MATERIAL TO SUPPORT THE LIVE LOAD

FIGURE 5.7 Placement of Passenger Support Flotation Material



5.1 Example of Level Flotation Calculations

Assume an outboard engine-powered runabout with the following specifications:

Length Overall	18'-6"
Beam	7'-3"
Propulsion	140 HP Outboard engine
Engine weight	457 lb. (including controls and battery)
Fuel	Portable fuel tank
Maximum weight capacity	1,400 lb.
Maximum persons capacity	1,100 lb. or 8 persons
Dry Hull weight	800 lb. (fiberglass 650 lb. + plywood 150 lb.)
Dry deck weight	300 lb. (fiberglass 245 lb. + plywood 55 lb.)
Deck hardware	228 lb. (Mostly aluminum)
Hull hardware	110 lb. (Aluminum 80 lb. + stainless steel 30 lb.)
Total weight	1,895 lb.

From Section 1.0 we determine that this boat must comply with the Level Flotation requirements. It is an outboard powered, more than 2 HP, mono-hull boat under 20 feet in length, and the requirements include a Level Flotation system and some tests to determine its compliance.

In Level Flotation we must establish a swamped waterline, or the position in which the boat will float after preconditioning and swamped for 18 hours (see regulation). We will assume in this example that this swamped line is at the hull sheer or deck-to-hull joint; therefore, the hull will be considered swamped and its component's weight converted to submerged weight, while the deck will be considered as dry weight since it will be out of the water.

We will now run through the calculation steps to determine the amount of flotation material necessary, and where to install it.

Step 1: Flotation material needed to support the swamped boat.

Formula: $F_b = [(W_h \times K) + W_d] \div B$

Let's identify the boat's components:

Part Description	Weight		Factor (K) Table 4.1		Submerged Weight
W_h = Weight of fiberglass hull	650	x	0.33	=	214.5
+ Weight of hull fir plywood	150	x	-0.81	=	-121.5
+ Weight of hull aluminum hardware	80	x	0.63	=	50.4
+ Weight of hull steel hardware	30	x	0.88	=	26.4
W_h = Swamped weight of hull					169.8 lb.

W _d = Weight of fiberglass deck	245
+	
Weight of fir plywood on deck	55
+	
Weight of factory installed equipment (dry)	228
<hr/>	
W_d = Weight of dry deck	528 lb.

B will be calculated as follows (assuming use of Polyurethane foam of 2.0 lb. density):

$$B = 62.4 - 2.0 = 60.4; \text{ then allow for 5\% moisture absorption } (2.0 \times 0.05 = 0.1)$$

$$B = 60.3 \text{ lb.}$$

Substituting in the formula above:

$$F_b = (169.8 + 528) \div 60.3 = 11.57$$

$$F_b = 11.6 \text{ cubic feet of foam}$$

This foam should be installed under the floors, symmetrically distributed about the boat's balance point.

Step 2: Determine the flotation material needed to support the swamped propulsion equipment (F_p).

Formula: $F_p = S \div B$

Where: S = The swamped weight of the maximum horsepower capacity engine for which the boat is rated on the capacity label, plus the submerged weight of the battery.
 B = The buoyancy of the flotation material in pounds per cubic foot.

The boat has been rated for a 140 HP outboard engine. When the boat is swamped, this engine will be partially submerged to the power head or the cowling — approximately. Table 4 (in Appendix A) gives us the weights needed here. Look at the Table. The 140 HP engine falls in the 80.1–145.0 range and, while the dry weight of the engine may be more, the number to use is the swamped (Column 2) weight. To this we must add the weight of the battery, and since it is going to be submerged, we use the submerged weight.

Therefore, $S = 352 + 25 = 377 \text{ lb.}$

And, $B = 60.3$ as calculated before

Substituting in the formula above:

$$F_p = 377 \div 60.3 = 6.3 \text{ cubic feet of foam}$$

This is the portion of the total foam that must be carefully located inside the volume formed by the portion of the boat forward of the top of the transom, where the engine is mounted.

NOTE:

The outboard engine weights in 33 CFR Subpart H (see Appendix A Table 4 of this Guideline), are outdated and much lighter than modern 4 stroke outboard engines. The reader is encouraged to refer to ABYC Standard S-30, Outboard Engines and Related Equipment Weights, for the latest outboard engine weight table. It is strongly recommended here that manufacturers use this new table of weights and be conservative on this important point

Step 3: Determine the flotation material needed to support the persons capacity (F_c).**Formula:**

$$F_c = \frac{.5(\text{first 550 lb. of persons capacity}) + .125(\text{remaining persons capacity}) + .25(C_{lev} - \text{persons capacity})}{B}$$

Where: C_{lev} = C (maximum weight capacity) minus weight in column 6, Table 4 for the maximum horsepower rating of the boat. (See Appendix A.)
 B = Buoyancy of flotation material in pounds per cubic foot.

Be careful here. Let's substitute in the formula one step at a time to avoid confusion. Let's add the weight components first and then divide by B.

Look at the specifications. The boat has been rated for:

- Persons capacity in pounds = 1,100 lb.
- Maximum weight capacity = 1,400 lb.

$$\begin{aligned} F_c &= .5 \text{ of the first 550 lb. of persons capacity} = .50 \times 550 = 275 \text{ lb.} \\ &+ \\ &.125 \text{ of the remaining persons capacity} = .125 (1,100 - 550) = 68.75 \text{ lb.} \\ &+ \\ &.25 \text{ of } C_{lev} \text{ minus the persons capacity (col. 6 Table 4 — Appendix A)} = .25 [(1,400 - 550) - 1,100] \\ &= -62.5 \text{ (Since this is less than 0, use 0)} \end{aligned}$$

$$F_c = (275 \text{ lb.} + 68.75 \text{ lb.} + 0) \div 60.3 = 5.70 \text{ cubic feet of foam}$$

This foam should be distributed along the hull sides and under the deck gunnels in the passenger carrying areas.

Step 4: Determine the total flotation material needed for Level Flotation.

Formula: $F = F_b + F_p + F_c$

$$F = 11.6 + 6.3 + 5.7 = 23.6 \text{ cubic ft. of foam flotation}$$

5.2 Summary of Level Flotation Performance Requirements & Tests

Each boat subject to compliance with Level Flotation must have sufficient flotation so that after pre-conditioning, the boat will pass the following requirements (Read section 183.220):

1. Flotation Test
2. Stability Test
3. Level Flotation Test

The boat, if selected for testing by the USCG, will be prepared and tested as this Guideline describes, and pre-conditioning the boat is a very important part of the test.

The manufacturer can:

- Perform the tests in-house;
- Hire an independent firm to perform tests and report results; or
- Take advantage of the USCG program as they will perform these tests free of charge.

Test One: Flotation Test

Performance requirements:

Following the pre-conditioning and loading (see section 3 of this Guideline), the boat has to meet requirements a, b and c of CFR 183.225

FEDERAL LAW:**183.225 Flotation test for persons capacity.**

Flotation standard. When the conditions prescribed in Sec. 183.220 are met, the boat must float in fresh, calm water as follows:

- (a) The angle of heel does not exceed 10 degrees from the horizontal.
- (b) Any point on either the forward or aft reference area is above the surface of the water.
- (c) The reference depth at the reference area that is opposite the reference area that is above the surface of the water is 6 inches or less.

FIGURE 5.8 Flotation Test

FIGURE 5.9 Reference Area



Test Two: Stability Test**FEDERAL LAW:****183.230 Stability Test.**

- (a) Flotation standard. When the conditions prescribed in Sec. 183.220 (a), (d) through (h) and paragraphs (b) and (c) of this section are met, the boat must float in fresh, calm water as follows:
- (1) The angle of heel does not exceed 30 degrees from the horizontal.
 - (2) Any point on either the forward or aft reference area is above the surface of the water.
 - (3) The reference depth at the reference area that is opposite the reference area that is above the surface of the water is 12 inches or less.
- (b) Quantity of weight used. Load the boat with a quantity of weight that, when submerged, is equal to the sum of the following:
- (1) One-half of the quantity of weight required by Sec. 183.220 (b) (1).
 - (2) The quantity of weight required by Sec. 183.220 (b) (2).
- (c) Placement of quantity of weight: starboard side. Place the weight required by paragraph (b) of this section in the boat so that:
- (1) The quantity of weight required by Sec. 183.220 (b) (2) is positioned in accordance with Sec. 183.220 (c); and
 - (2) One-half the quantity of weight required by Sec. 183.220 (b) (1) is uniformly distributed over a distance along the outboard perimeter of the starboard side of the passenger carrying area that is equal to at least 30 percent of the length of the passenger carrying area so that the center of gravity of the quantity of weight is located within the shaded area illustrated in Figure 12, the center of gravity of the amount of weight placed on the floor of the boat is at least 4 inches above the floor, and the center of gravity of the amount of weight placed on a seat is at least 4 inches above the seat. The location and dimensions of the shaded area are as follows:
 - (i) The shaded area is centered at the mid-length of the passenger carrying area;
 - (ii) The length of the shaded area is equal to 70 percent of the length of the passenger carrying area; and
 - (iii) The breadth of the shaded area is 6 inches from:
 - (A) For weights placed on the floor, the outboard perimeter of the passenger carrying area; and
 - (B) For weights placed on a seat, a vertical line inside the passenger carrying area as illustrated in Figure 13.
- (d) Placement of quantity of weight: port side. The quantity of weight required by paragraph (b) (1) of this section is placed along the port side of the passenger carrying area in accordance with the conditions prescribed in paragraph (c) (2) of this section.

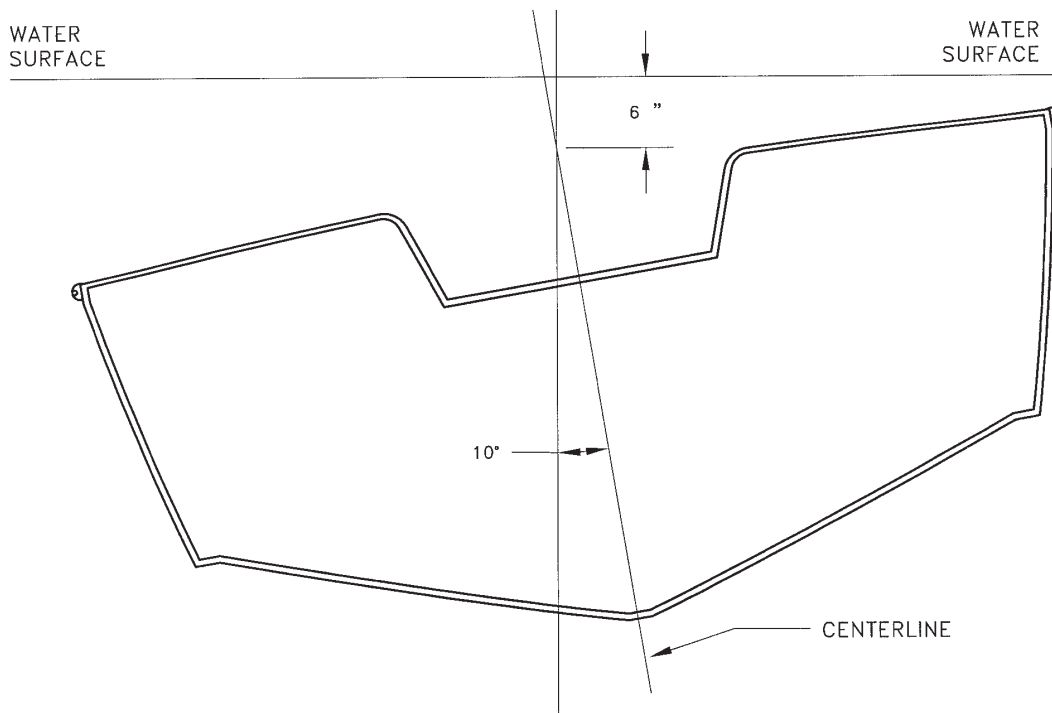
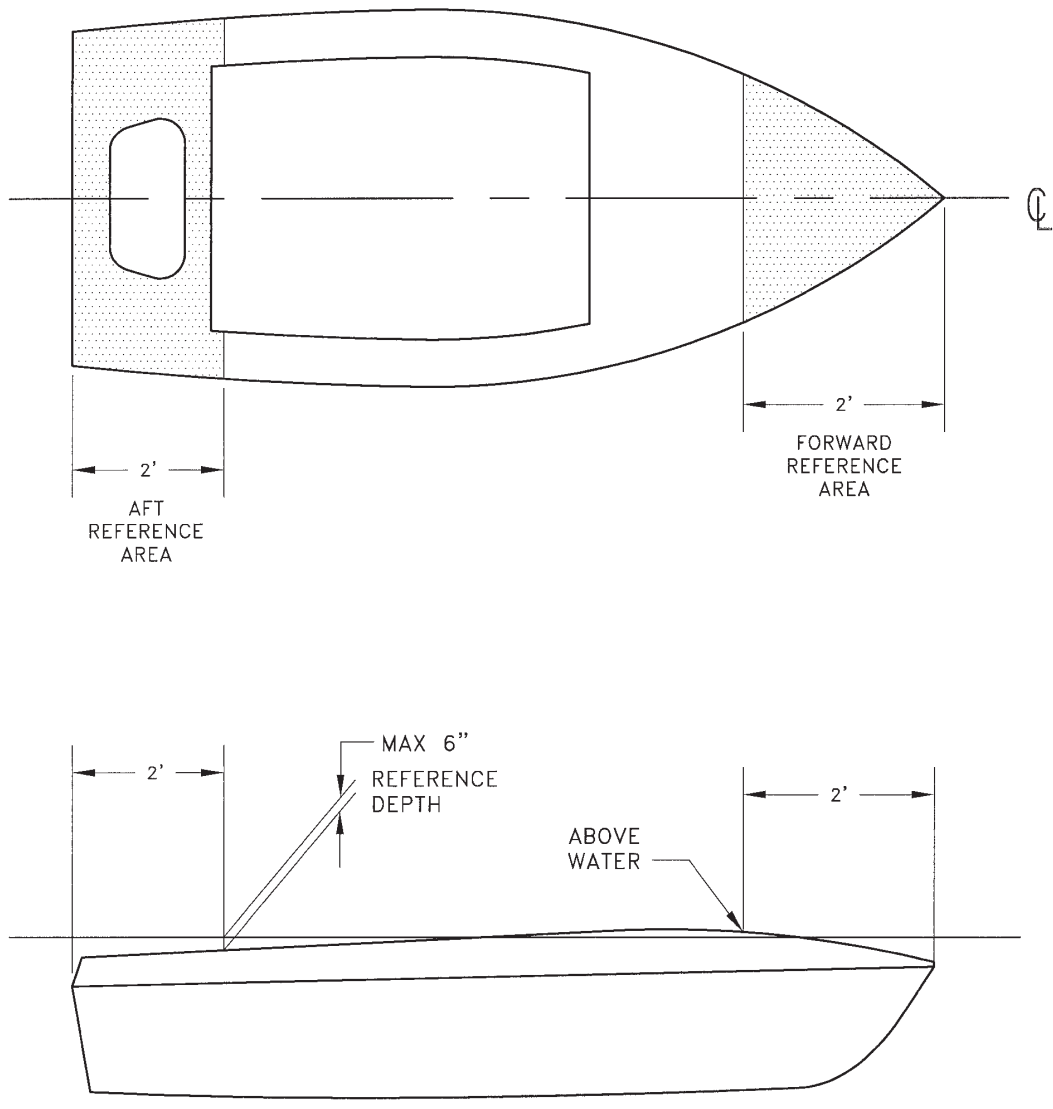
Performance Requirements: Following the pre-conditioning and loading (see section 3 of this Guideline), the boat must meet the requirements 1, 2 and 3 of section 183.230 (a)

NOTE:

- 1) See Appendix B for 33 CFR Subpart H, Figures 2–13.
- 2) The boat must meet the performance requirements when tested with the weights on each side of the boat.

FIGURE 5.10 Stability Test

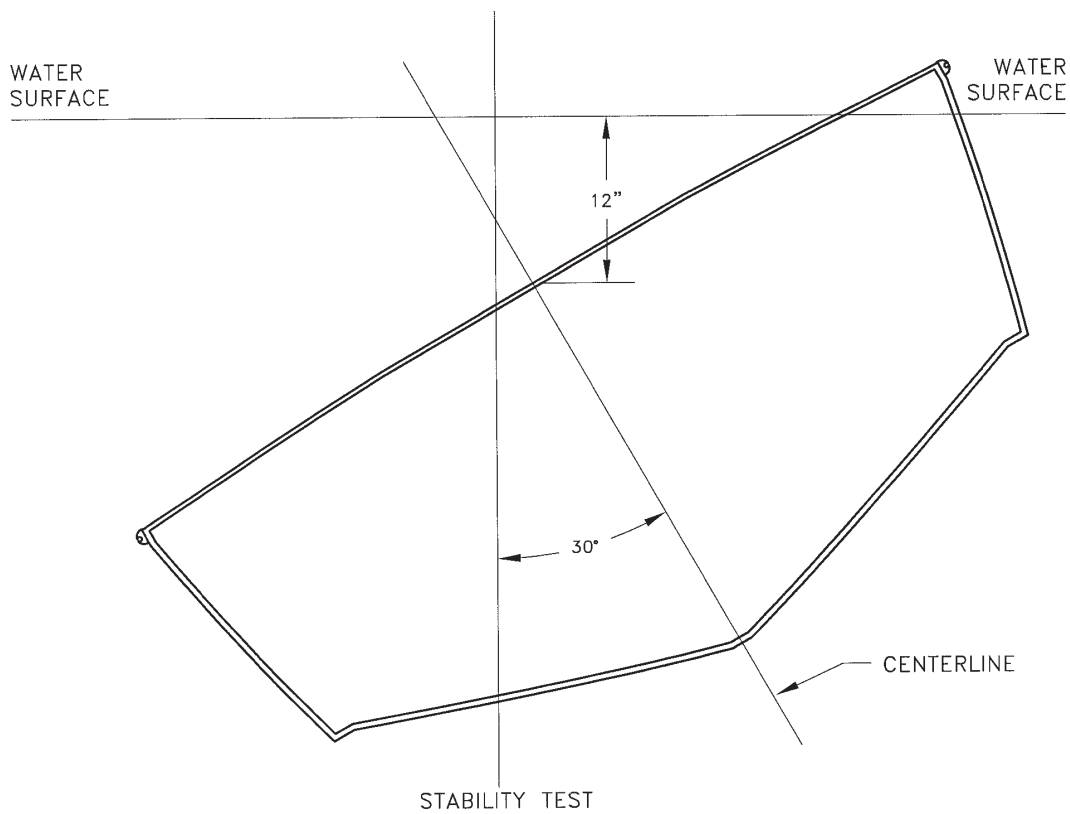

FIGURE 5.11 Loading Area

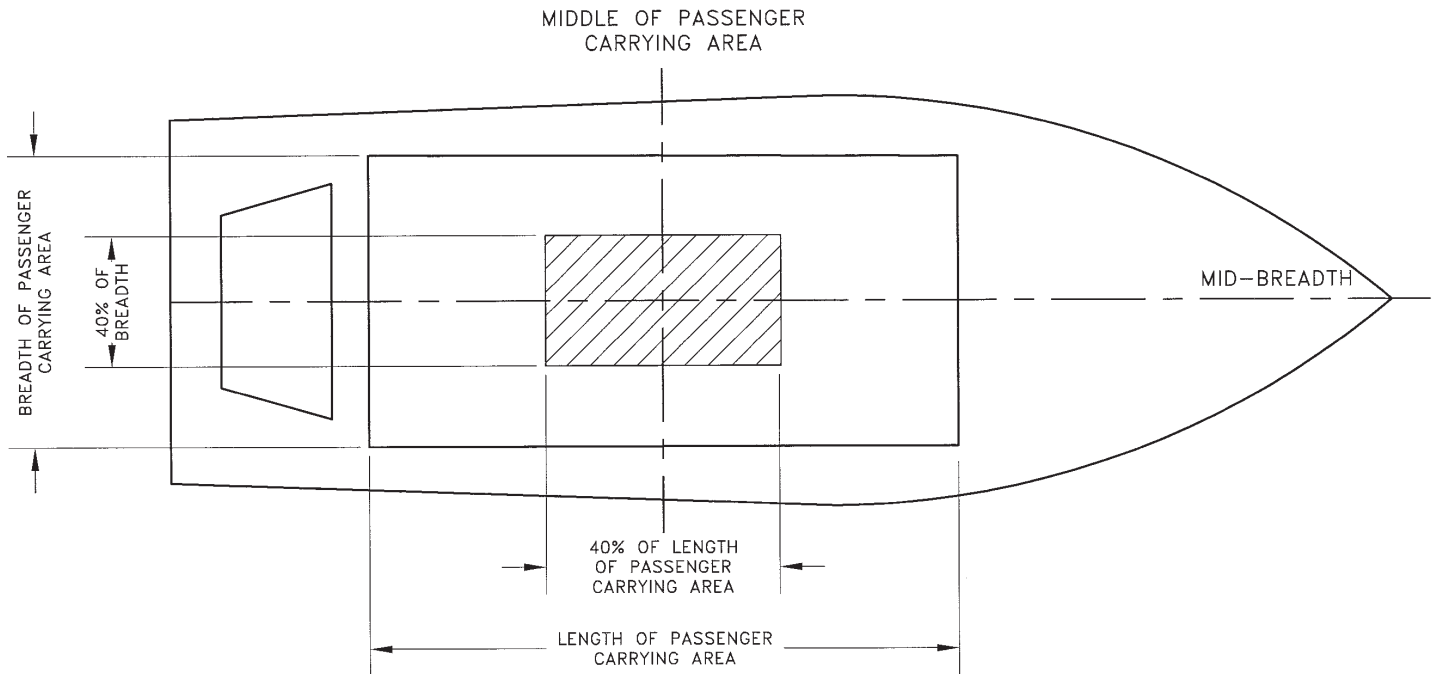
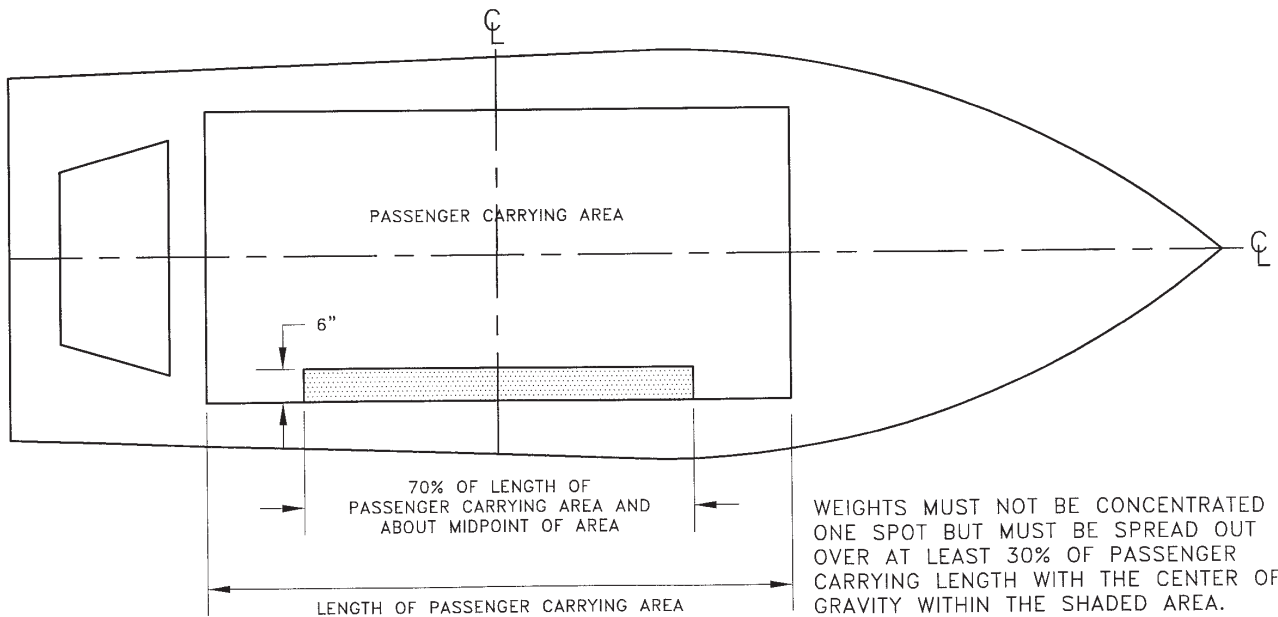

FIGURE 5.12 Center of Gravity of Weights

CENTER OF GRAVITY OF WEIGHTS MUST BE:

1. LONGITUDINALLY: WITHIN 70% OF THE COCKPIT LENGTH
2. TRANSVERSELY: WITHIN 6" OF SIDE OF PASSENGER CARRYING AREA
3. VERTICALLY: 4" OR MORE ABOVE FLOOR AND SEATS



WEIGHTS MUST NOT BE CONCENTRATED IN ONE SPOT BUT MUST BE SPREAD OUT OVER AT LEAST 30% OF PASSENGER CARRYING LENGTH WITH THE CENTER OF GRAVITY WITHIN THE SHADED AREA.

FIGURE 5.13 Weight Shift for Stability Tests

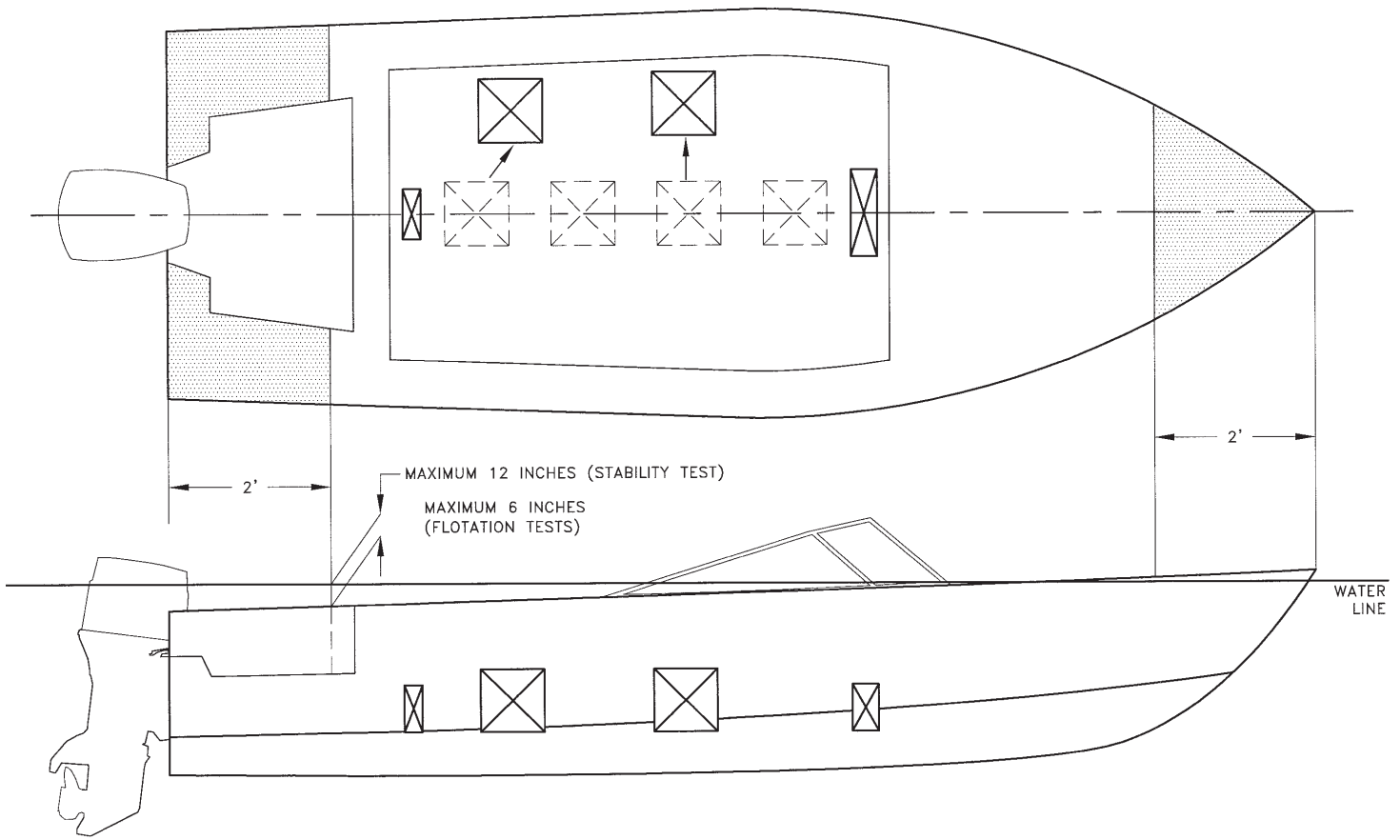
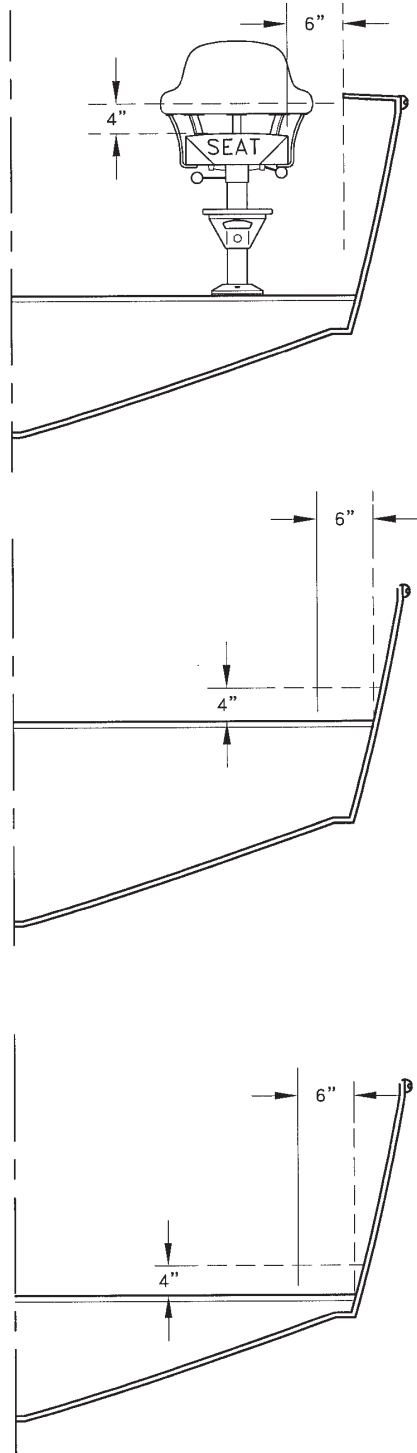

FIGURE 5.14 Center of Gravity of Weight on Seats



Test Three: Level Flotation Test (without certain weights)

FEDERAL LAW:

183.235 Level flotation test without weights for persons capacity.

When the conditions prescribed in Sec. 183.220 (a) and (d) through (h) are met, the boat must float in fresh, calm water as follows:

- (a) The angle of heel does not exceed 10 degrees from the horizontal.
- (b) Any point on either the forward or aft reference area is above the surface of the water.
- (c) The reference depth at the reference area that is opposite the reference area that is above the surface of the water is 6 inches or less.

The flotation attitude requirements for this test are the same as for Test One, but the loading excludes weights for persons capacity as specified in 183.230 (c) (2) (ii) and (c) (2) (iii).

NOTE:

The purpose of this test is to check that the boat, without weights for passengers, will not capsize. The weights may actually help the boat stay level because of a lower center of gravity while, if removed, the boat could overturn if the flotation material buoys up the center of the boat.

6.0 Modified Level Flotation

FEDERAL LAW:

183.302 Flotation requirements.

Each boat to which this subpart applies must be manufactured, constructed, or assembled to pass the stability and flotation tests prescribed in Secs. 183.325 (a), 183.330 (a), and 183.335 (a).

Boats requiring Modified Level Flotation shall be fitted with buoyant materials or acceptable flotation systems in at least the minimum quantities determined below.

Void compartments within the hull shall not be included as part of the flotation material. However, boats with outboard engines of 2 HP or less, as well as manually propelled boats, may use integral air chambers. For testing purposes, these need not be punctured or disabled, nor do the non-integral air chambers used in these same boats.

A special situation for Modified Level Flotation exists when there is a need to determine the flotation materials necessary for the boat shown in the following example, **but only if it is rated solely for manual propulsion**. Step 1 is the same; step 2 is omitted (no engine); and Step 3 is changed to reflect C = maximum weight capacity with no deductions. Therefore, Step 4 adds two factors instead of three. This Guideline presents the calculations for a boat rated for 2 HP or less, while the example will be different for a powered boat and for one manually propelled.

Calculations for Modified Level Flotation

Step 1: Determine the flotation needed to support the swamped boat (F_b)

Formula: $F_b = [(W_h \times K) + W_d] \div B$

Where: W_h = dry weight of hull (everything below swamped waterline)
 W_d = dry weight of deck and superstructure
 K = conversion factors for materials used
 B = buoyancy of flotation materials used, in pounds per cubic foot

NOTE:

*If air is used, B will simply be 62.4 pounds (the weight of fresh water displaced by 1 cu ft). If foam is used, B will equal the weight of 1 cu. ft. of fresh water, **minus** the weight of one cu. ft. of the foam used, **minus** the amount of water absorbed by this foam when submerged for 18 hours.*

This flotation material shall be distributed symmetrically about the balance point of the boat.

Step 2: Determine the flotation needed to support the swamped propulsion equipment (F_p)

NOTE:

If the boat is manually propelled only, proceed to Step 3.

Formula: $F_p = S \div B$

Where: S = swamped weight for 2.0 HP outboard, from Table 4 (Appendix A) = 20 lb.
B = buoyancy of flotation materials used, in pounds per cubic foot

Distribute the flotation material symmetrically within 30 inches of the outside of the transom top at the motor mounting area.

Step 3: Determine the flotation material needed to support the persons capacity (F_c)

Formula: $F_c = 0.25 (C_{mod}) \div B$

Where: C_{mod} = C (maximum weight capacity) minus dry weight of the engine
B = buoyancy of flotation materials used, in pounds per cubic foot

NOTE:

The maximum weight capacity includes the engine, the flotation of which was calculated in Step 2 above. The dry weight of the 2 HP engine (20 lb.) must then be deducted from the maximum weight capacity posted.

The regulations call for 2/15 (.133) of the persons capacity. This Guideline uses .25, resulting in slightly more flotation material for the boat.

The flotation material should be distributed symmetrically, transversely and fore and aft of the midpoint of the passenger carrying area, and at the hull sides as close to the gunwales as possible. This will help the boat float in a level attitude when swamped.

Step 4: Determine the total flotation material needed (F)

Formula: $F = F_b + F_p + F_c$

Where: F_b = flotation for the boat (Step 1)
 F_p = flotation for outboard motor, 2 HP or less (Step 2)
 F_c = flotation for persons capacity and gear (Step 3)

6.1 Examples Modified Flotation Calculations

Example 1: Boat rated for 2 horsepower.

Assume a boat with the following specifications:

W_h weight of hull (fiberglass)	80 lb.
W_d weight of deck (fir plywood)	5 lb.
Boat is rated for 2 HP	
S (swamped weight of 2 HP engine)	20 lb. (See Appendix A, Table 4)
C (Maximum weight capacity)	300 lb.
B (buoyancy of flotation material in lb./cu.ft.)	60.3 lb.

Step 1: Determine flotation needed to support the swamped boat (F_b).

Formula: $F_b = [(W_h \times K) + W_d] \div B$

Substituting in the formula above:

$$F_b = [(80 \times 0.33) + 5] \div 60.3$$

$$F_b = [(26.4) + 5] \div 60.3$$

$$F_b = 0.52 \text{ cu. ft.}$$

Step 2: Determine flotation needed to support the propulsion equipment (F_p).

Formula: $F_p = S \div B$

Substituting in the formula above

$$F_p = 20 \div 60.3$$

$$F_p = 0.33 \text{ cu. ft.}$$

Step 3: Determine the flotation needed to support the persons capacity (F_c).

Formula: $F_c = 0.25 (C_{mod}) \div B$

$$F_c = 0.25 (300-25) \div 60.3$$

$$F_c = 1.14 \text{ cu. ft.}$$

NOTE:

The regulations call for 2/15 (0.133) of the persons capacity; however, this Guideline's calculations use .25, which results in slightly more flotation for the boat.

Step 4: Determine the total flotation material needed.

Formula: $F = F_b + F_p + F_c$
 $F = 0.52 + 0.33 + 1.14$

 $F = 1.99 \text{ cu. ft.}$

Example 2: Boat rated for manual propulsion only.

Assume the same boat as in example 1 above, but rated for manual propulsion only (no power).

Step 1: Determine flotation needed to support the swamped boat (F_b).

Formula: $F_b = [(W_h \times K) + W_d] \div B$

Substituting in the formula above:

$$F_b = [(80 \times 0.33) + 5] \div 60.3$$

$$F_b = [(26.4) + 5] \div 60.3$$

 $F_b = 0.52 \text{ cu. ft.}$

Step 2: Flotation for engine: OMIT.**Step 3: Determine the flotation needed to support the persons capacity (F_c).**

Notice we omit the weight of the engine and leave maximum weight capacity at 300 lb.

Formula: $F_c = 0.25 (C) \div B$
 $F_c = 0.25 (300) \div 60.3$

 $F_c = 1.24 \text{ cu. ft.}$

Step 4: Determine the total flotation material needed.

Formula: $F = F_b + F_c$
 $F = 0.52 + 1.24$

 $F = 1.76 \text{ cu. ft.}$

6.2 Summary of Modified Flotation Performance Characteristics

Each boat must have flotation such that, after pre-conditioning (namely when the boat has been submerged in calm, fresh water for at least 18 hours), it will float as follows:

Test 1: Flotation Test

See Section 3.0 for preparation and preconditioning.

FEDERAL LAW:

183.325 Flotation test for persons capacity.

Flotation standard. When the conditions prescribed in Sec. 183.320 are met, the boat must float in fresh, calm water as follows:

- (a) The angle of heel does not exceed 10 degrees from the horizontal.
- (b) Any point of either the forward or aft reference area is above the surface of the water.
- (c) The reference depth at the reference area that is opposite the reference area that is above the surface of the water is 6 inches or less.

See Figure 5.8 Flotation Test.

Test 2: Stability Test**FEDERAL LAW:****183.330 Stability test.**

- (a) Flotation standard. When the conditions prescribed in Sec. 183.320 (a), (d) through (g) and paragraphs (b) and (c) of this section are met, the boat must float in fresh, calm water as follows:
- (1) The angle of heel does not exceed 30 degrees from the horizontal.
 - (2) Any point on either the forward or aft reference area is above the surface of the water.
 - (3) The reference depth at the reference area that is opposite the reference area that is above the surface of the water is 12 inches or less.
- (b) Quantity of weight used. Load the boat with quantity of weight that, when submerged, is equal to the sum of the following:
- (1) One-half the quantity of weight required by Sec. 183.320 (b) (1).
 - (2) The quantity of weight required by Sec. 183.320 (b) (2).
- (c) Placement of quantity of weight: starboard side. Place the quantity of weight required by paragraph (b) of this section in the boat so that:
- (1) The quantity of weight required by Sec. 183.320 (b) (2) is positioned in accordance with Sec. 183.320 (c); and
 - (2) One-half the quantity of weight required by Sec. 183.320 (b) (1) is uniformly distributed over a distance along the outboard perimeter of the starboard side of the passenger carrying area that is equal to at least 30 percent of the length of the passenger carrying area so that the center of gravity of the quantity of weight is located within the shaded area illustrated in Figure 12, the center of gravity of the amount of weight placed on the floor of the boat is at least 4 inches above the floor and the center of gravity of the amount of weight placed on a seat is at least 4 inches above the seat. The location and dimensions of the shaded area are as follows:
 - (i) The shaded area is centered at the mid-length of the passenger carrying area;
 - (ii) The length of the shaded area is equal to 70 percent of the length of the passenger carrying area; and
 - (iii) The breadth of the shaded area is 6 inches from:
 - (A) For weights placed on the floor, the outboard perimeter of the passenger carrying area; and
 - (B) For weights placed on a seat, a vertical line inside the passenger carrying area as illustrated in Figure 13.
 - (3) Placement of quantity of weight: port side. The quantity of weight required by paragraph (b)(1) of this section is placed along the port side of the passenger carrying area in accordance with the conditions prescribed in paragraph (c)(2) of this section.

Test 3: Flotation Test (without weights)

The flotation attitude requirements for this test are the same as for Test 1, but the loading excludes weights for persons capacity and dead weight.

NOTE:

The purpose of this test is to check that the boat, without weights for passengers and dead weight, will not capsize. These weights may actually help the boat stay level because of a lower center of gravity while, if removed, the boat could overturn if the flotation material buoys up the center of the boat.

FEDERAL LAW:

183.335 Level flotation test without weights for persons capacity.

When the conditions prescribed in Sec. 183.320 (a) and (d) through (g) are met, the boat must float in fresh, calm water as follows:

- (a) The angle of heel does not exceed 10 degrees from the horizontal.
- (b) Any point on either the forward or aft reference area is above the surface of the water.
- (c) The reference depth at the reference area that is opposite the reference area that is above the surface of the water is 6 inches or less.

7.0 Flotation Materials

There are specific performance specifications for flotation materials based upon their location in a boat. The level of performance required depends on the degree of exposure to detrimental agents. Each section of the federal regulation related to a specific type of flotation, i.e., Basic, Level, or Modified Level, provides requirements addressing flotation material. The requirements refer the reader to Sec. 183.114 which follows.

The terms "bilge", "engine room bilge" and "engine room" have been defined (see section 2.0). The first step will be to establish the bilge and engine room bilge areas within the boat.

With the unloaded boat in calm, fresh water and transversely level (static floating position):

- The bilge is the volume located below a line parallel to the reference waterline. This line is located 4" up from the lowest point where water may accumulate in the boat.
- The engine room bilge is the volume located below a line parallel to the reference waterline. This line is located 12" up from the point where water may accumulate within this compartment (or connected compartments)

FIGURE 7.1

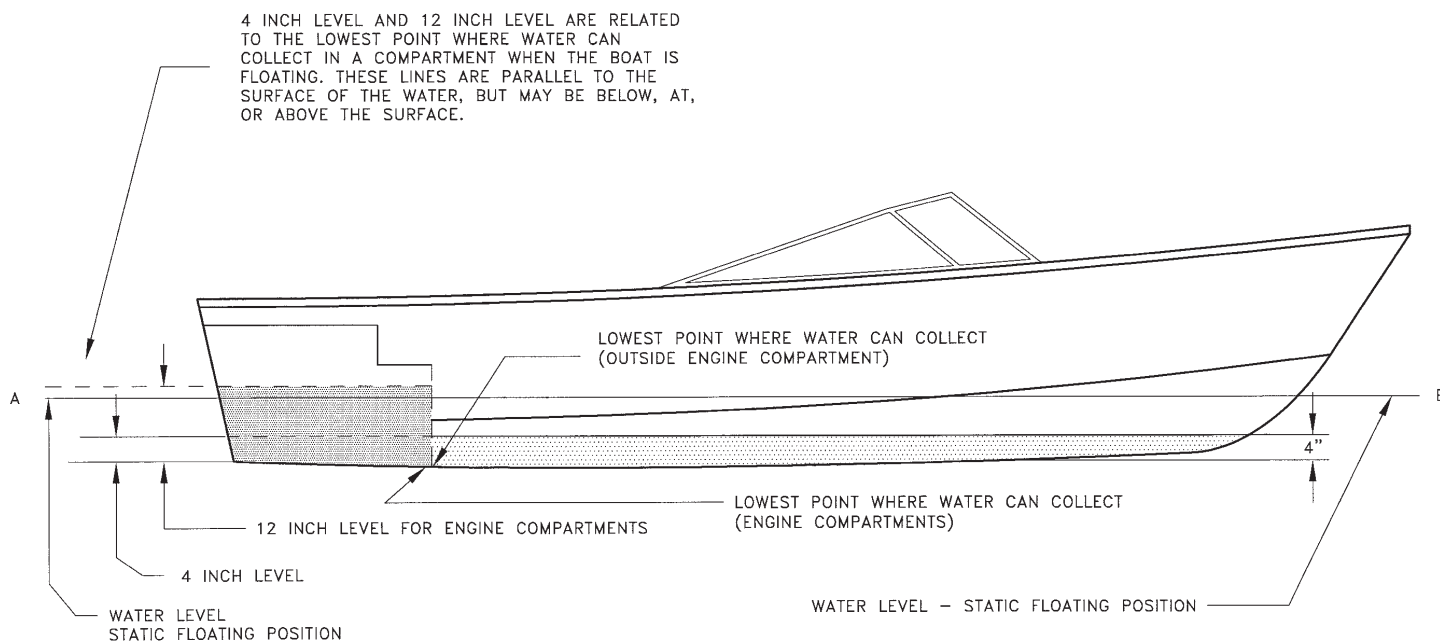
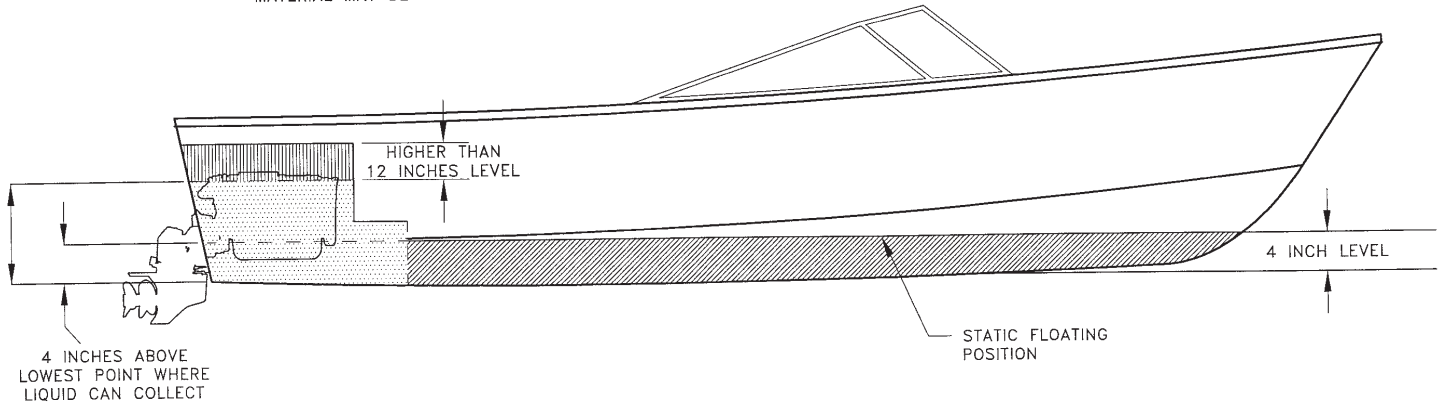

FIGURE 7.2 Boat in Static Floating Position

FOR SPECIFIC FOAM LOCATION REQUIREMENTS, REFER TO 183.114

NOTE: IF FLOTATION MATERIAL IS ENCLOSED OR ENCASED ANY FLOTATION MATERIAL MAY BE USED ANYWHERE.



7.1 Requirements

Basic Flotation Material Requirements

FEDERAL LAW:

- 183.112 Flotation material and air chambers.
- (a) Flotation materials must meet the requirements in Sec. 183.114 as listed in Table 183.114 when used in the: (1) Engine room bilge, (2) engine room, or (3) bilge, unless located in a sealed compartment.
 - (b) Air chambers used to meet the flotation requirements of this subpart must not be integral with the hull.

Level Flotation Material Requirements

FEDERAL LAW:

- 183.222 Flotation material and air chambers.
- (a) Flotation materials must meet the requirements in Sec. 183.114 as listed in Table 183.114 when used in the bilge, unless located in a sealed compartment.
 - (b) Air chambers used to meet the flotation requirements of this subpart must not be integral with the hull.

Modified Level Flotation Material Requirements

FEDERAL LAW:

- 183.322 Flotation materials.
- (a) Flotation materials must meet the requirements in Sec. 183.114 as listed in Table 183.114 when used in the bilge, unless located in a sealed compartment.

7.2 Flotation Material Tests

FEDERAL LAW:

- 183.114 Test of flotation materials.
- (a) Vapor test. The flotation material must not reduce in buoyant force more than 5 percent after being immersed in a fully saturated gasoline vapor atmosphere for 30 days at a minimum temperature of 38 deg. C.
 - (b) 24-hour gasoline test. The flotation material must not reduce in buoyant force more than 5 percent after being immersed for 24 hours at 23 plus or minus 2 deg.C in reference fuel B, of ASTM D 471 (incorporated by reference, see Sec. 183.5).
 - (c) 30-day gasoline test. The flotation material must not reduce in buoyant force more than 5 percent after being immersed for 30 days at 23 plus or minus 2 deg.C in reference fuel B, of ASTM D 471 (incorporated by reference, see Sec. 183.5).
 - (d) 24-hour oil test. The flotation material must not reduce in buoyant force more than 5 percent after being immersed for 24 hours at 23 plus or minus 2 deg.C in reference oil No. 2, of ASTM D 471 (incorporated by reference, see Sec. 183.5).
 - (e) 30-day oil test. The flotation material must not reduce in buoyant force more than 5 percent after being immersed for 30 days at 23 plus or minus 2 deg.C in reference oil No. 2, of ASTM D 471 (incorporated by reference, see Sec. 183.5).
 - (f) 24-hour bilge cleaner test. The flotation material must not reduce in buoyant force more than 5 percent after being immersed for 24 hours at 23 plus or minus 2 deg.C in a 5-percent solution of trisodium phosphate in water.
 - (g) 30-day bilge cleaner test. The flotation material must not reduce in buoyant force more than 5 percent after being immersed for 30 days at 23 plus or minus 2 deg.C in a 5-percent solution of trisodium phosphate in water.
 - (h) The buoyant force reduction in paragraphs (a) through (g) of this section is measured in accordance with ASTM D 2842 (incorporated by reference, see Sec. 183.5).

Table 183.114 Flotation Performance Tests

	Area 183.110		
	(b) Engine-room bilge	(c) Engine-room unless open to atmosphere	(d) Bilge
(a) Vapor test		X	
(b) 24 hour gasoline test			X
(c) 30 day gasoline test	X		
(d) 24 hour oil test			X
(e) 30 day oil test	X		
(f) 24 hour bilge cleaner test			X
(g) 30 day bilge cleaner test	X		

NOTES:

- 1) *The change in volume and buoyancy is measured in accordance with ASTM D-2842. The maximum size of a test sample shall be 6" x 6" x 3" and cut by the same method used to shape it for use in the boat.*
- 2) *Flotation material does not have to be gasoline, oil, gasoline vapor or trisodium solution-resistant if:*
 - a. *Used in manually propelled boats;*
 - b. *Installed outside the engine compartment more than 4 inches above the lowest point where liquid can collect when the boat is in its static floating position; or*
 - c. *Enclosed or encased in an enclosure that permits no more than one-quarter ounce of fresh water per hour to enter when the enclosure is submerged to a depth of 12 inches.*
- 3) *Cellular plastic used to encase fuel tanks is allowed to count as a flotation material, but it must conform to the following applicable conditions (33 CFR 183.516 of the USCG Fuels Systems regulations):*
- 4) *For the purposes of these tests, ASTM oils and ASTM fuels, and a trisodium phosphate solution have been selected which approximate typical marine products with which flotation material may come in contact in actual service.*
- 5) *ASTM reference fuel B provides typical swelling effects produced by commercial gasolines, and ASTM No. 2 reference oil has been chosen since it characterizes the nearest aniline point of a petroleum-based oil used in marine service. The aniline point of petroleum oil determines the swelling action of the oil. Reference fuel B consists of 70% Isooctane and 30% Toluene, in volume (Isooctane conforming to Section Annex A2.8, Motor Fuels Section of 1973-74 ASTM Manual for Rating Motor, Diesel and Aviation Fuels; Toluene conforming to ASTM D-362 for Industrial Grade Toluene).*
- 6) *For a full explanation of the test fuels, refer to ASTM D-471.*

FEDERAL LAW:

- 183.516 Cellular plastic used to encase fuel tanks
- (a) Cellular plastic used to encase metallic fuel tanks must:
- (1) Not change volume by more than five percent or dissolve after being immersed in any of the following liquids for 24 hours at 29 deg.C:
 - (i) Reference fuel B ASTM D 471 (incorporated by reference, see Sec. 183.5).
 - (ii) No. 2 reference oil of ASTM D 471 (incorporated by reference, see Sec. 183.5).
 - (iii) Five percent solution of trisodium phosphate in water; and
 - (2) Not absorb more than 0.12 pound of water per square foot of cut surface, measured under Military Specification MIL P-21929B.
- (b) Non-polyurethane cellular plastic used to encase metallic fuel tanks must have a compressive strength of at least 60 pounds per square inch at ten percent deflection measured under ASTM D 1621 (incorporated by reference, see Sec. 183.5), "Compressive Strength of Rigid Cellular Plastics".
- (c) Polyurethane cellular plastic used to encase metallic fuel tanks must have a density of at least 2.0 pounds per cubic foot, measured under ASTM D 1622 (incorporated by reference, see Sec. 183.5), "Apparent Density of Rigid Cellular Plastics."

NOTE:

If cellular plastic was used to encase a fuel tank and is counted as flotation material, it must meet the above stated requirements.

Of the many foams available, foamed polystyrene and polyurethane are the most common. They are noted here because of their broad use, but not to the exclusion of other types of flotation material.

Foamed polystyrene is a low-cost material produced from expandable beads (“pop corn”) or extruded in the form of billets or boards. The common name is “Styrofoam.” In its common forms, it is readily dissolved in gasoline and is highly flammable. There are special compounds of polystyrene foam that are solvent-resistant and self-extinguishing. One objection to foamed polystyrene is that it cannot be foamed in place, and it usually cannot be produced in a boat builder's plant. Caution is necessary because some varieties have “wormholes” which reduce the flotation value.

Polyurethane foam is another widely used buoyancy material. It is usually foamed in place or molded into specific shapes before installation. It is also available in slabs and billets. Polyurethane foam is normally highly resistant to gasoline and oil, particularly in densities of 4.0 pounds per cubic foot and higher. Even in densities of 1.5 to 2 pounds per cubic foot, it is considered very resistant to gasoline and oil. Polyurethane foam is flammable, but it can be made self-extinguishing. In densities of less than 2 pounds per cubic foot, it may absorb significant amounts of water.

Air chambers used to achieve flotation are usually made of plastic materials. They must be capable of withstanding the same solvent-resistance tests as other flotation materials, and they must pass the required 18-hour submergence preconditioning before undergoing the flotation tests.

7.3 Installation Requirements

a) **Air Chambers**

Air chambers shall maintain their integrity under pre-test conditioning and under flotation test conditions. They shall not leak when subjected to an internal air pressure test and shall not allow the ingress of water when submerged to at least a depth equal to that required in the flotation test.

b) **Plastic Foam Blocks and Other Shapes**

- 1) A method of identifying foam blocks and other shapes must be employed to assure that each boat gets the correct amount of flotation in the correct location.
- 2) Expanded polystyrene foam must not come in contact with uncured polyester resin or fumes.
- 3) Foam blocks and other shapes must be secured so that no movement in any direction occurs that will effect the flotation's performance.

- 4) Installation must be in a manner that will prevent:
 - damage from occupant contact
 - deterioration from exposure to direct sunlight
 - damage from normal use of the boat.
 - 5) The space provided for the installation of foam blocks must be large enough to prevent the necessity of using force that will deform the shape of the block during the installation process. Deformation will lower the volume, and therefore the total buoyancy, of the foam block.
- c) **Sprayed or Poured Liquid Mix**
- 1) When liquid flotation material is installed directly in place, constraints must be provided in the form of bulkheads, boxes or dams to ensure the proper volume, and to ensure that the centers of buoyancy are correctly placed.
 - 2) Clearance around, and passages through, the foam should be provided for:
 - routing controls, cables and wires;
 - access to windshield fasteners, cleat and chock fasteners, rail fasteners, ventilation ducts, other deck hardware and standard fittings;
 - bilge drainage;
 - drainage of the top of metallic fuel tanks (see Fuel Systems Compliance Guideline).

FIGURE 7.3

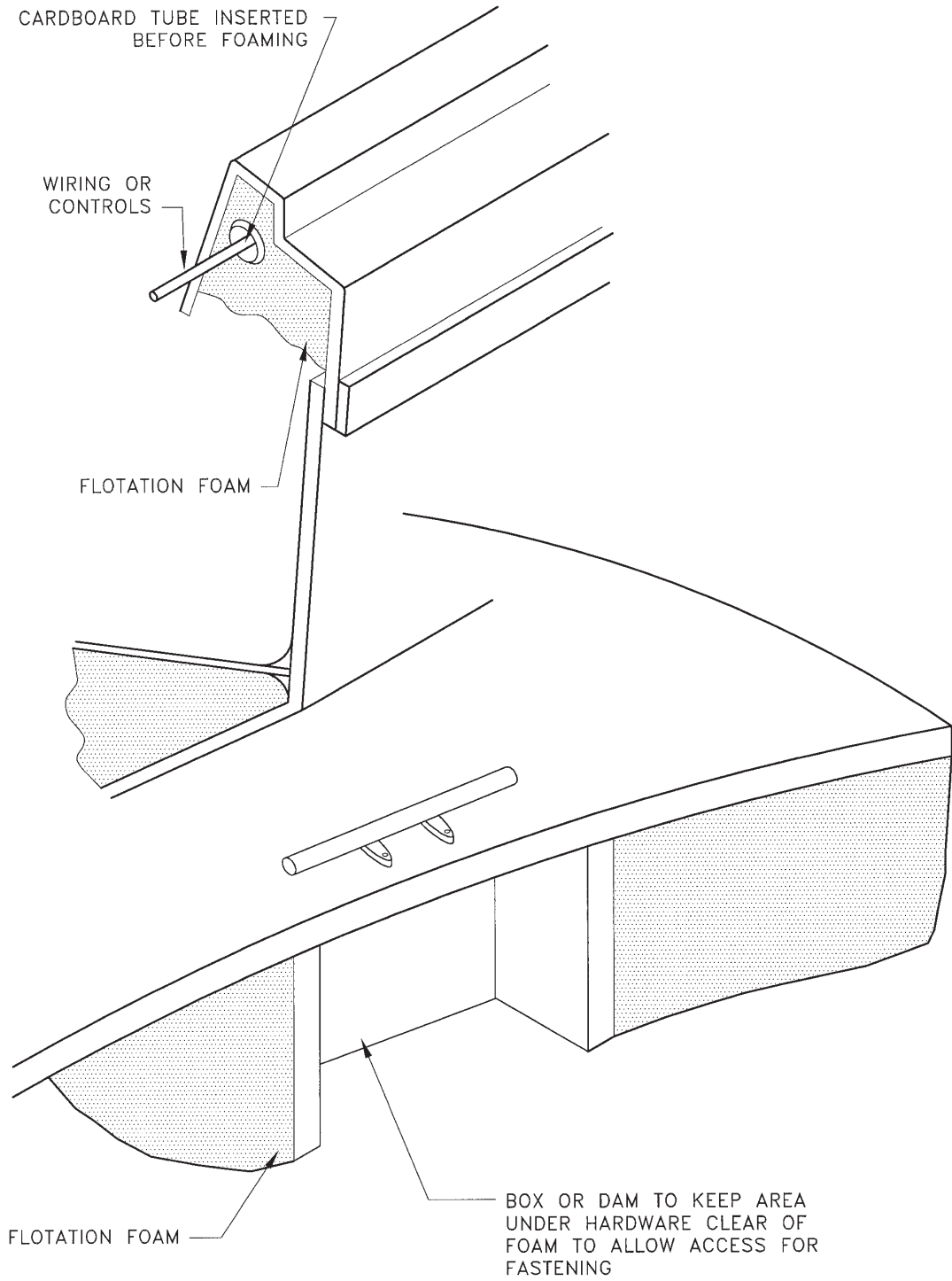

FIGURE 7.4

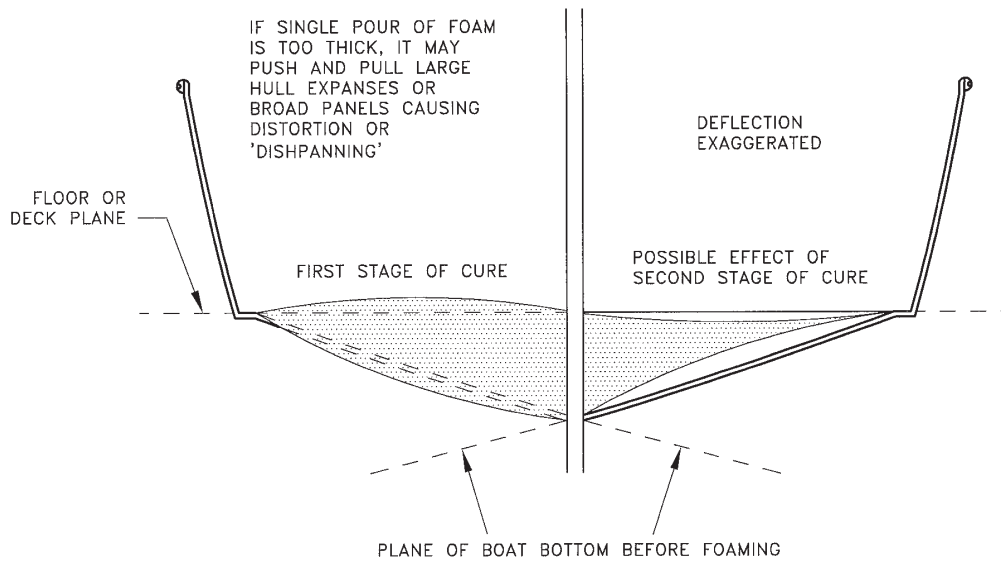

FIGURE 7.5 Flotation Material — Protection from Damage

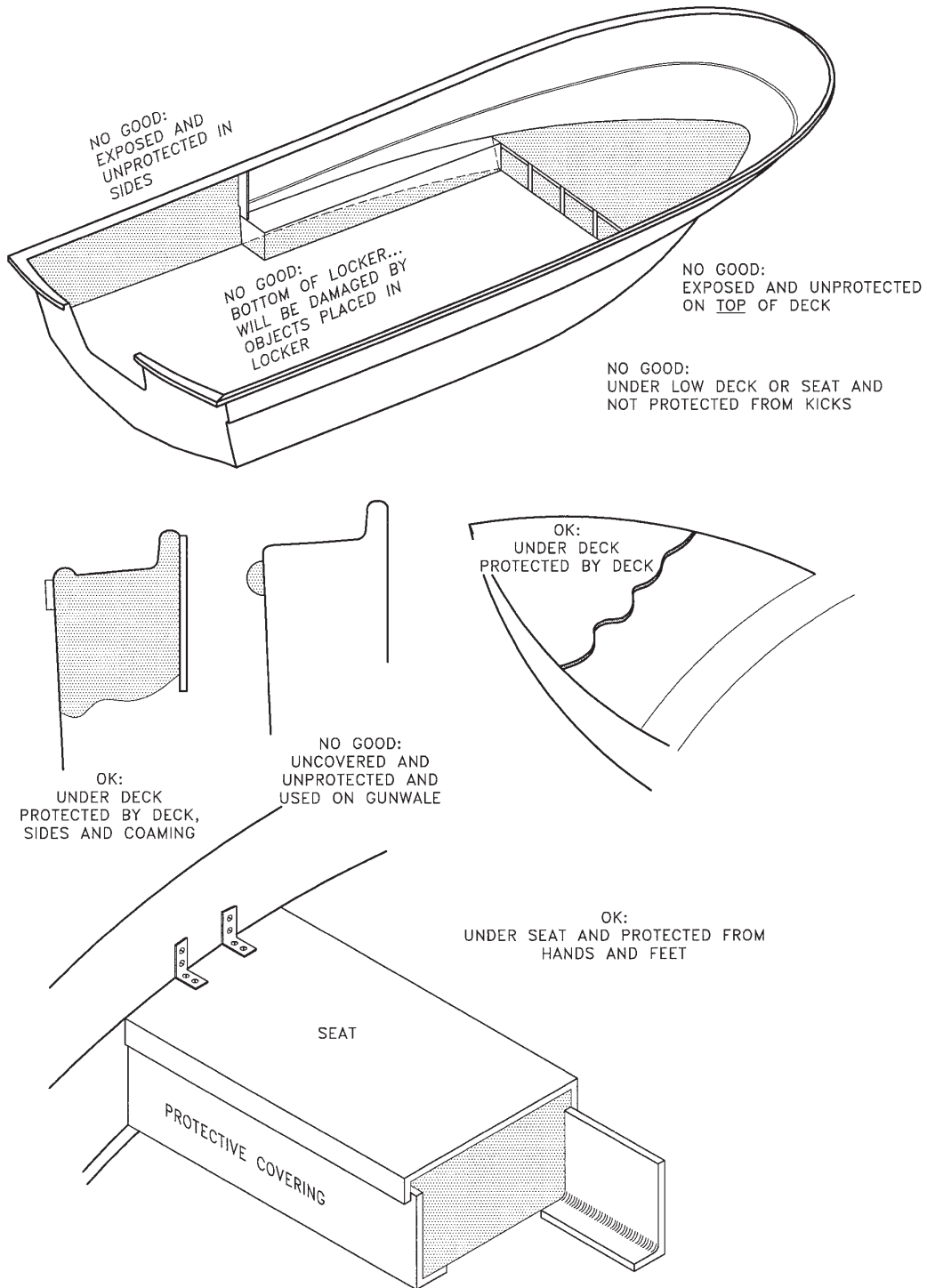
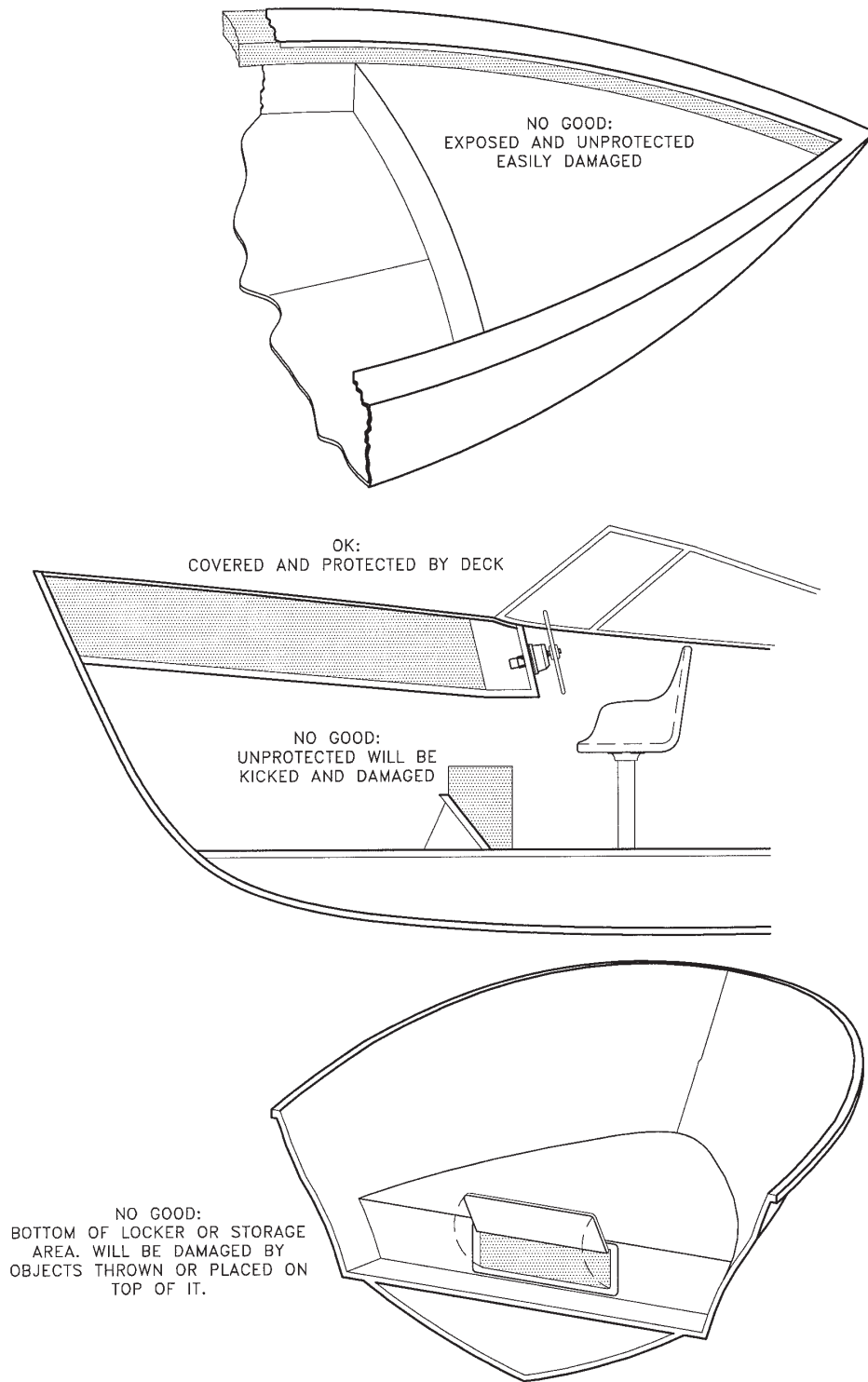

FIGURE 7.6 Flotation Material — Protection from Damage



Appendix A

33 CFR Part 183, Table 4: Weight (Pounds) of Outboard Motor and Related Equipment for Various Boat Horsepower Ratings

Boat Horsepower Rating	Motor and Control Weight		Battery Weight		Full Portable Fuel Tank Weight	1+3+5
	DRY	SWAMPED	DRY	SUBMERGED		
Column No.	1	2	3	4	5	6
0.1 to 2.0	25	20	--	--	--	25
2.1 to 3.9	40	34	--	--	--	40
4.0 to 7.0	60	52	--	--	25	85
7.1 to 15.0	90	82	20	11	50	160
15.1 to 25.0	125	105	45	25	50	220
25.1 to 45.0	170	143	45	25	100	315
45.1 to 60.0	235	195	45	25	100	380
60.1 to 80.0	280	235	45	25	100	425
80.1 to 145.0	405	352	45	25	100	550
145.1 to 275.0	430	380	45	25	100	575
275.1 and up	605	538	45	25	100	750

Transoms Designed for Twin Motors

50.1 to 90.0	340	286	90	50	100	530
90.1 to 120.0	470	390	90	50	100	660
120.1 to 160.0	560	470	90	50	100	750
160.1 to 290.0	810	704	90	50	100	1000
290.1 to 550.0	860	760	90	50	100	1050
550.1 and up	1210	1076	90	50	100	1400

Appendix B

FIGURE 8 33 CFR SUBPART H, Figures 2-13

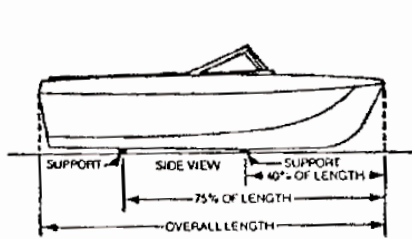

FIGURE 2. LOCATION OF SUPPORT* FOR LEVEL BOAT

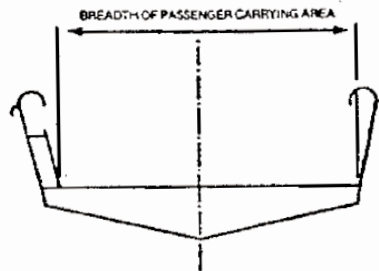

FIGURE 7.

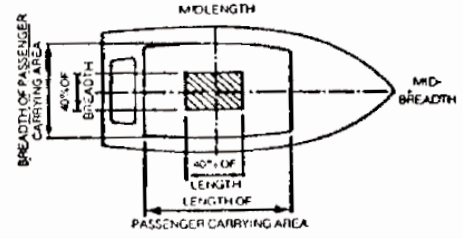

FIGURE 11. PASSENGER CARRYING AREA: LOCATION OF CENTER OF GRAVITY OF WEIGHTS

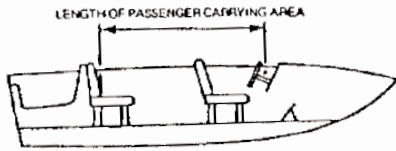

FIGURE 3. BOAT WITH DECK

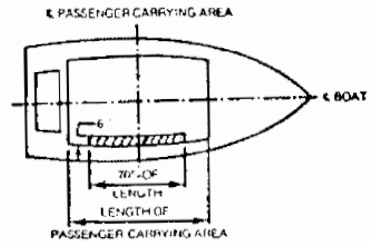

FIGURE 12. STABILITY TEST LOCATION OF CENTER OF GRAVITY OF WEIGHTS: STARBOARD SIDE

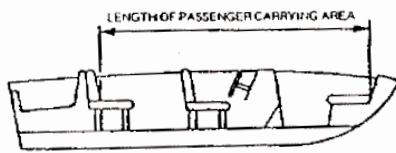

FIGURE 4. BOAT WITH CENTER CONSOLE

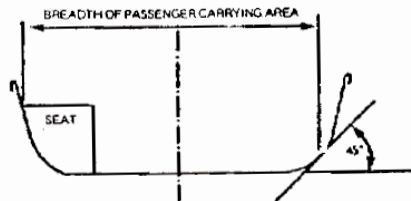

FIGURE 8. BOAT WITH ROUND CHINE

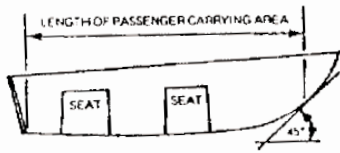

FIGURE 5. OPEN BOAT WITH CURVED STEM

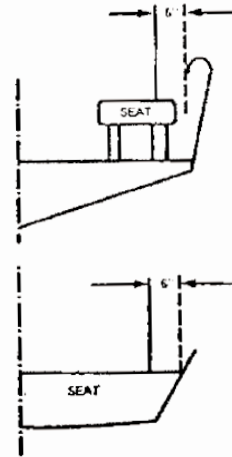

FIGURE 13. LOCATION OF CENTER OF GRAVITY OF WEIGHTS ON SEATS

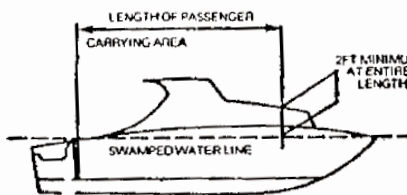

FIGURE 6. BOAT WITH CABIN

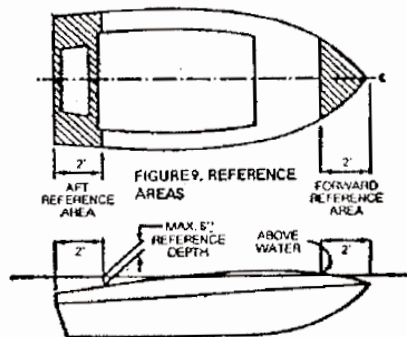

FIGURE 9. REFERENCE AREAS

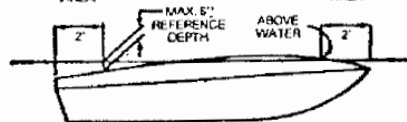

FIGURE 10. REFERENCE DEPTH

References

U.S. Coast Guard regulations are available from the U.S. Government Printing Office, Superintendent of Documents, Washington, DC 20402-9328.

ASTM, American Society of Testing and Materials, 100 Barr Harbor Drive, West Conshohocken, PA 19428-2959. Phone: (610) 832-9585 Fax: (610) 832-9555